



kelderman

Stock Height 4-Link
4wd - Front
Installation Manual

- 2019+ Chevrolet 4500-6500

Kit Number;

Kelderman 4-Link Air Ride

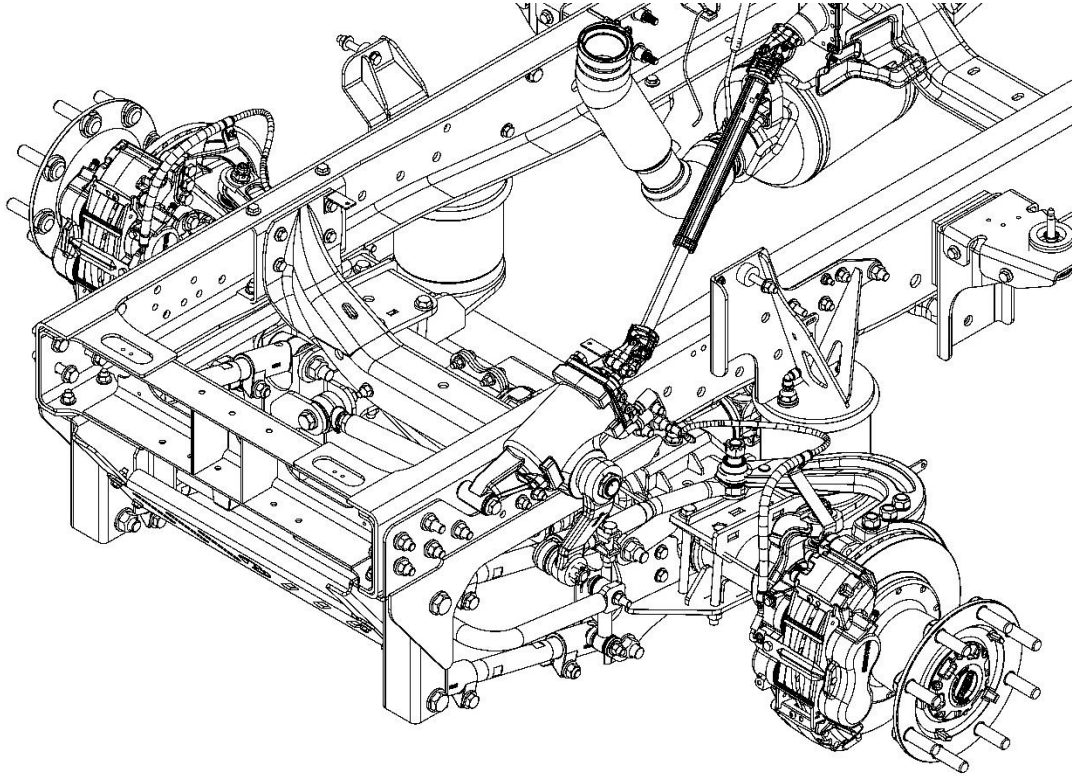

Stock Height

-	Contents	
-	Kit Numbers.....	(3)
-	Introduction.....	(4)
-	Safety.....	(5)
-	Product Owner Responsibilities.....	(6)
-	Disassembly.....	(7)
-	Kit Installation.....	(12)
-	Parts Key.....	(27)
-	Contact Information.....	(30)

Kit Numbers

- This installation manual covers the following air ride kits.

Kit Number	Description
10006664	2019+ Chevrolet 4500/5500/6500 – 4wd - 4-Link Front – Stock Height



Introduction

- **Important**

It is important that the entire installation instructions be read thoroughly before proceeding with installation.

- Before painting open every box and locate all parts. There are several smaller bushing pieces and bolts that are packaged separately inside the main box.

- **Product Installer Responsibilities**

Installer is responsible for installing this product in accordance with Kelderman Mfg. Inc. specifications and installation instructions.

Installer is responsible for providing proper installation of vehicle components and attachments as well as required or necessary clearance for suspension components, axles, wheels, tires, and other vehicle components to ensure a safe and sound installation and operation of this product.

- **Definition of Terms**

- **Warning:** Indicates a potentially hazardous situation which, if not avoided, could result in death or serious injury.
- **Caution:** A potential hazardous situation may result in property damage.
- **Note:** Provide information or suggestions that help correctly perform a task.
- **Torque:** When italicized "*torque*" alerts the installer to tighten fasteners to a specified value.

Safety

- **Your Safety and the Safety of Others is Very Important.**
Read and understand all safety precautions and instructions before installing this product.

- **CAUTION: Trucks Equipped with Parking Sensors or Other Like Devices.**
Relocation of these devices will alter the field of view. It is the responsibility of the owner to understand how these changes affect the operation of these systems.

- **WARNING: Components Under Pressure.**
Bleed all pressure from the air system before performing any maintenance or service. Serious injury could occur if components are removed while system is pressurized.

- **WARNING: Careless Installation Can Result in Serious Injury or Property Damage**
 - Wear eye protection.
 - Disconnect the battery before doing any work on the vehicle.
 - Work on flat level ground.
 - Ensure truck is properly supported by jack stands. Never work under a vehicle supported only by hydraulic jacks.
 - Take precautions when lifting product. Due to the size and weight of this product two people are recommended for installation.
 - Never work directly under the product until it has been securely fastened to the vehicle.
 - Avoid sharp, hot, and moving components when routing electrical cables and air lines.
 - If drilling inspect both sides of the surface and remove/relocate any objects located in the way.
 - Ensure all bolts are properly tightened before driving.

- Product Owner Responsibilities

- Product owner is solely responsible for pre-operation inspection, periodic inspections, maintenance, and use of the product as specified by Kelderman Mfg. Inc. Of particular importance is the re-torque of fasteners. This re-torque must be performed within 90 days or 1000 miles of this product being put into service.
- The Kelderman Air Suspension is fully automatic in controlling the height of the chassis when properly installed. No Manual Intervention to control air pressure or ride height is needed during the course of normal operation.
- The compressor switch must be on for the compressor to operate. With the switch in the on position the compressor will run when the tank pressure drops below 90psi, and continue to run until tank pressure reaches 125psi.
- The low pressure warning light indicates a severe drop in tank pressure (*below 45psi*) immediate corrective action should be taken to determine the cause of air loss. Compressor switch should be turned off if low pressure warning light remains on even after the compressor has run for a normal period of time. **NOTE:** The low pressure warning light can come on briefly when the "Dump" feature is being used.
- During difficult starting circumstances, (*extremely cold weather*) it is recommended to turn the compressor switch off until the vehicle is running, to limit current draw on the battery.
- When operating in temperatures below freezing it is important to purge moisture contained within the air tank on a daily basis. This is done by opening the petcock or pulling the lanyard on the air tank. Failure to purge moisture can cause the system to freeze and not operate properly.
- Product owner is responsible for "down time" expenses, cargo damage, and all business costs and losses resulting from a warrantable failure.
- **Service Intervals**

First 1,000 Miles

- Check Ride Height $\pm 1/4"$
- Check for air leaks around fittings.
- Check for any loose or rubbing hoses and wires.
- Re-torque all hardware.

Every 30,000 Miles

- Check Ride Height $\pm 1/4"$
- Check for air leaks around fittings.
- Grease panhard bar rod ends (*heim*)
- Inspect trailing arm bushings and panhard bar bushings for wear; replace if required.

Disassembly

- 1: With the vehicle on flat level ground measure the pinion angle and record it. The pinion will need to be set back to this measurement after installation. **NOTE:** Use masking tape or some other method to mark the location of this measurement.

Pinion angle _____



- 2: Take the following measurements for future reference. These measurements will be used to adjust the suspension after installation.

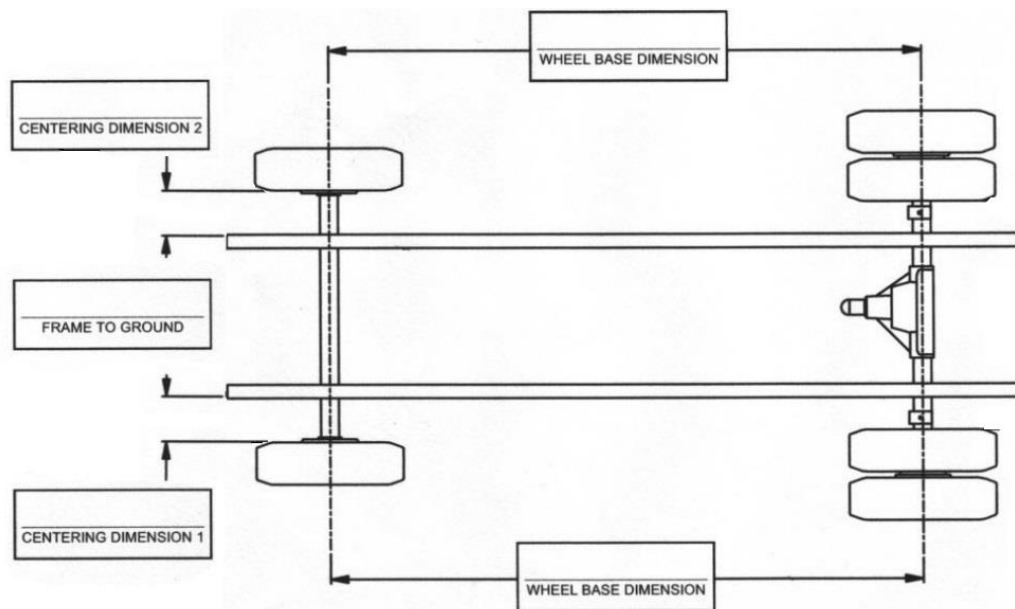

- 3: Break the front lug nuts loose, but do not remove.
- 4: Apply the parking brake. Lift the front of the vehicle just enough to take the weight off the leaf springs. Place jack stands under the frame and chock the front tires so the axle won't roll. Support the pinion with a jack stand.

- 5:** Remove the front bumper, bumper brackets (1) and tow hooks (if optional). These components will be re-installed later. **CAUTION:** Only remove the three bolts per side that fasten thru the bumper brackets.

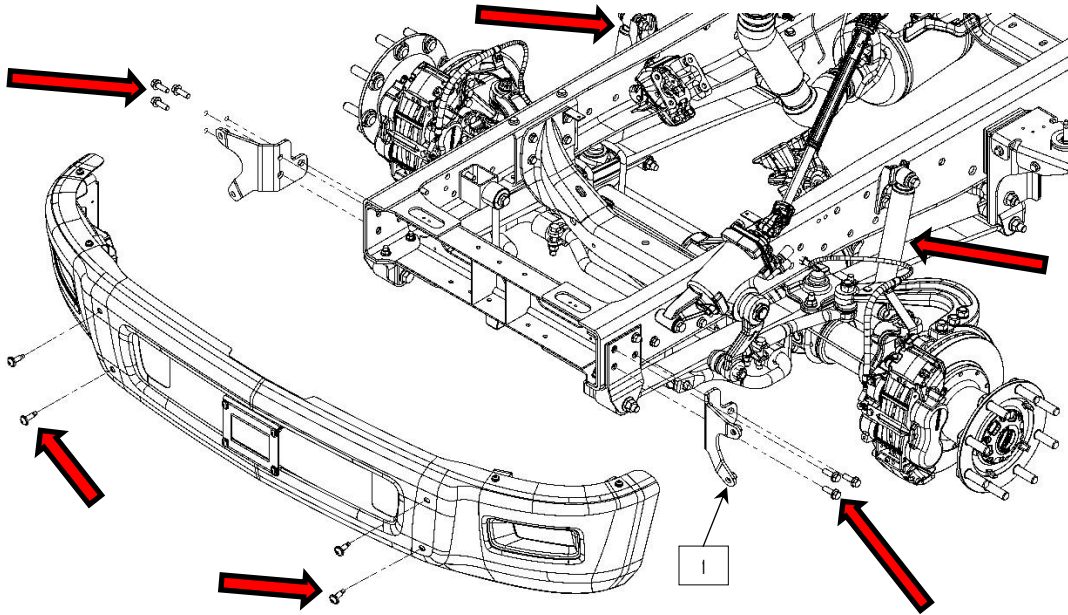

- 6:** Unbolt and remove the shock absorbers.

- 7:** Remove the lower radiator supports.

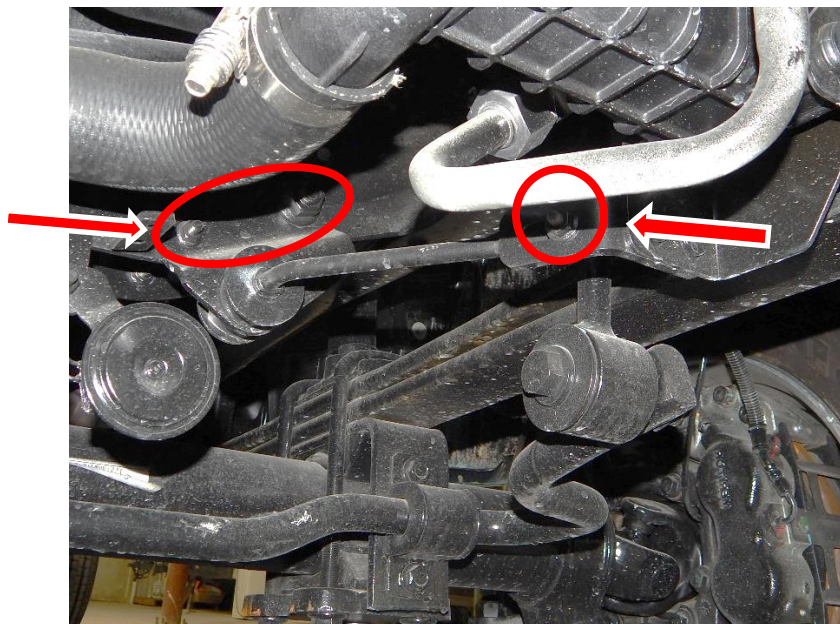

8: Remove the sway bar, end links, and end link brackets if equipped.

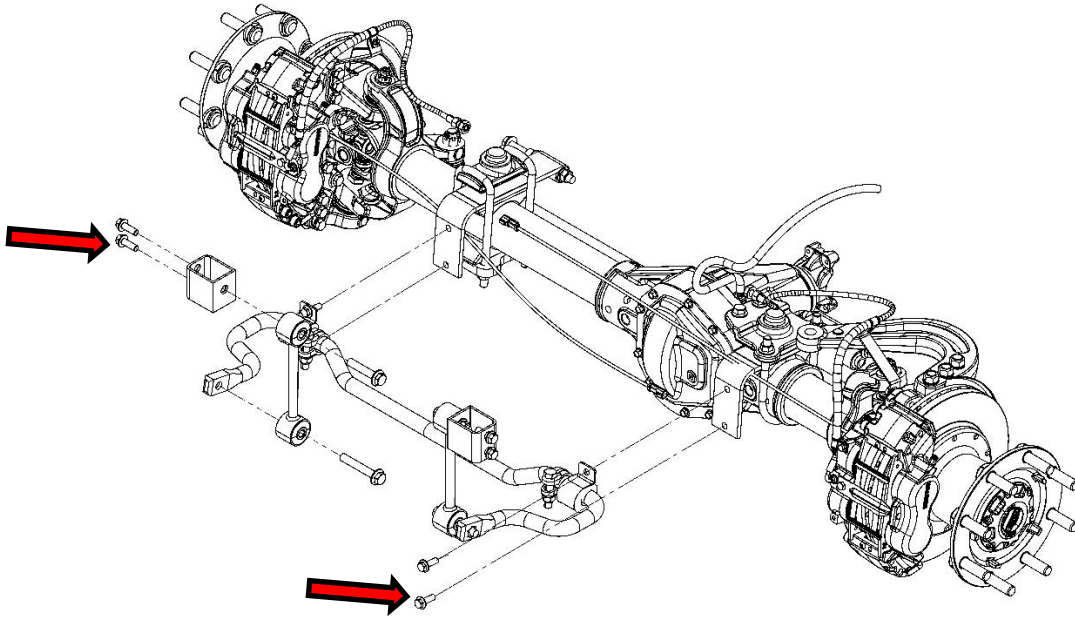

9: Unbolt the leaf springs from the axle.

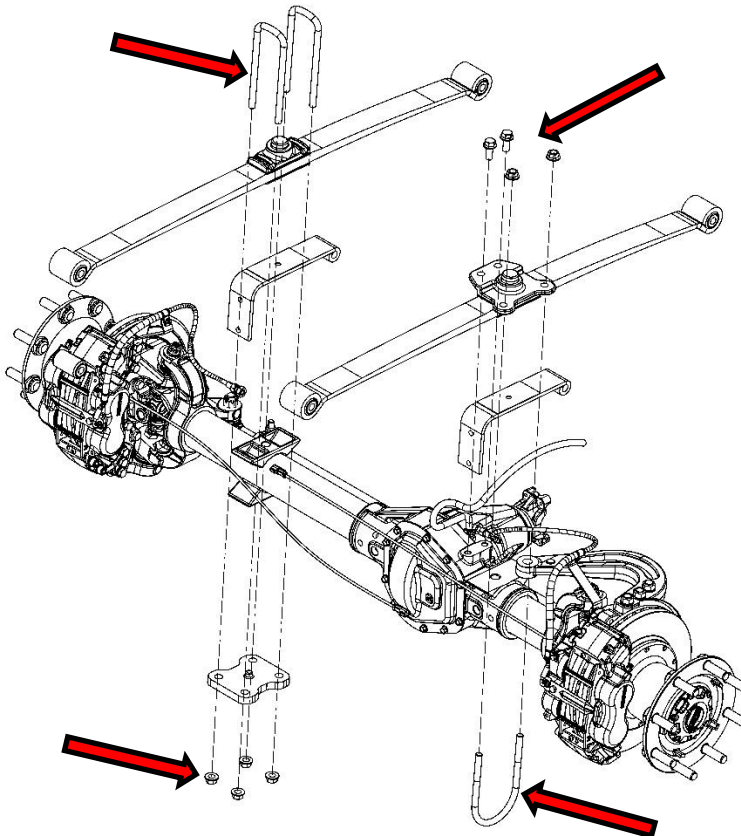

10: Remove the leaf springs and shackles from the frame.

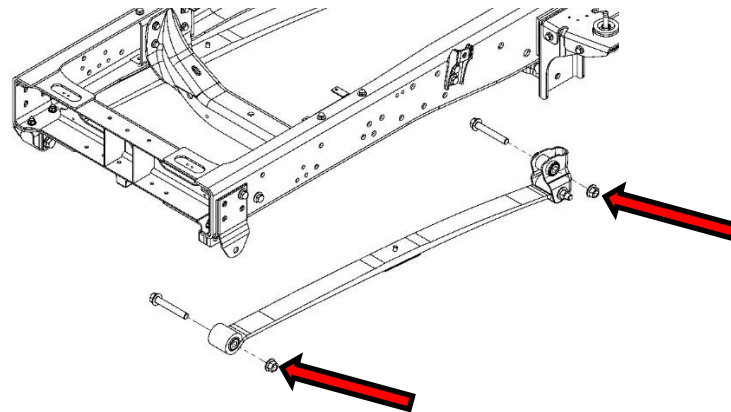

11: Support the axle on jack stands and remove the tires.

12: Mark, measure, and note the frame width at the front crossmember. Using those same marks measure the frame diagonally too check for square. These measurements will be compared against when installing the side plates.

Frame Width: Front _____ Diagonal Measurement #1 _____
 Diagonal Measurement #2 _____

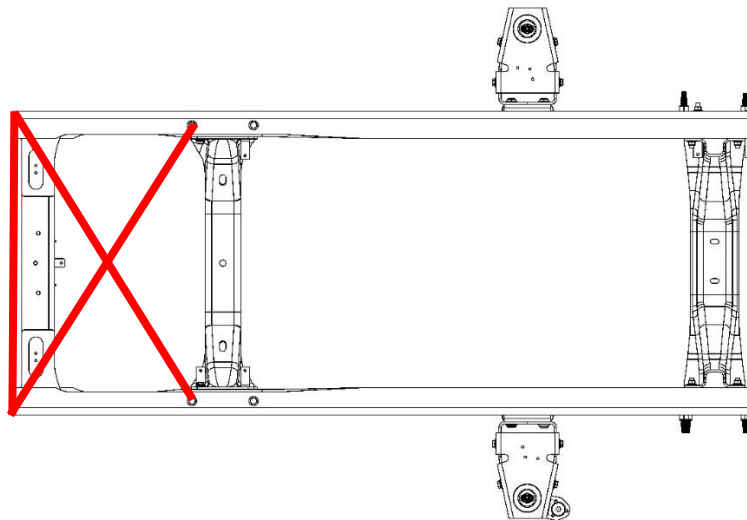

13: Remove the shock brackets and the power steering line bracket.

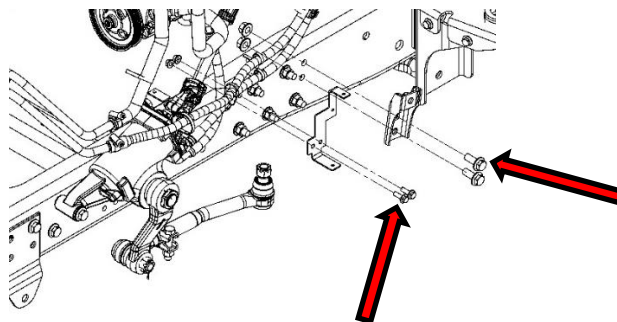

- 14:** Support the first and second crossmembers. Remove the front spring hanger from the frame. Remove the two bolts that fasten the second crossmember to the lower flange on the frame rail. **NOTE:** At this point it is recommended to only remove parts from one frame rail then install new components before moving to the opposite side.

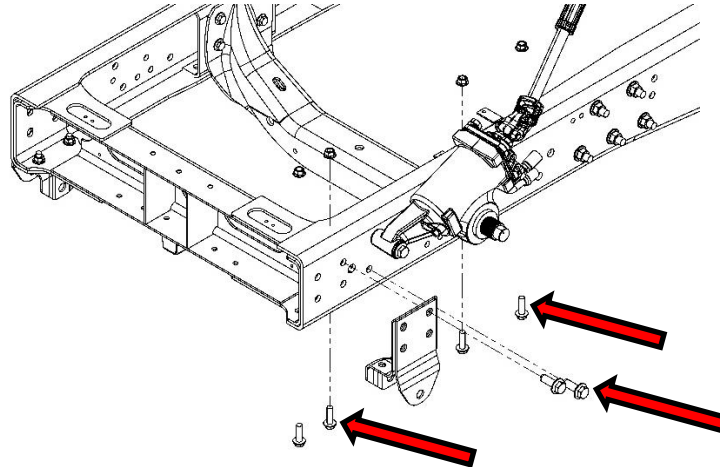

- 15:** To remove the huckbolts split the nut using a cutoff wheel or an air chisel.

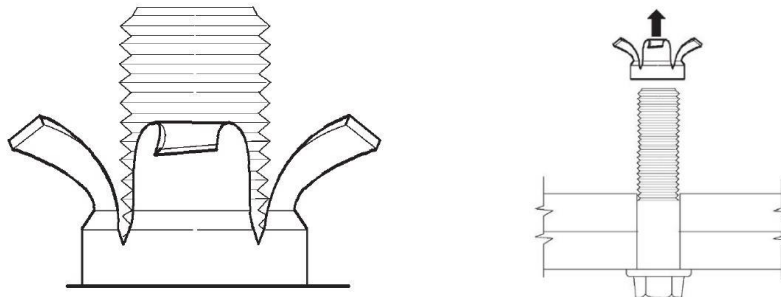

- 16:** To install the driver's side proceed to *step 1* of the *Kit Installation* section. To install the passenger's side proceed to *step 7* of the *Kit Installation* section.

Kit Installation

- 1:** Realign the forward crossmember with the marks made during disassembly and bolt side plate (2) onto the frame rail using 5/8" hardware (4, 5, 6, 7, & 8). Use 1/2" hardware (9, 10, & 11) under the steering box. The longest two 5/8" bolts (6) fasten thru the OEM tow hook and the bumper bracket (1). If you do not have stock tow hooks, you will need to use 5/8" - 18 - 2-1/2" bolts instead of the 3-1/2".

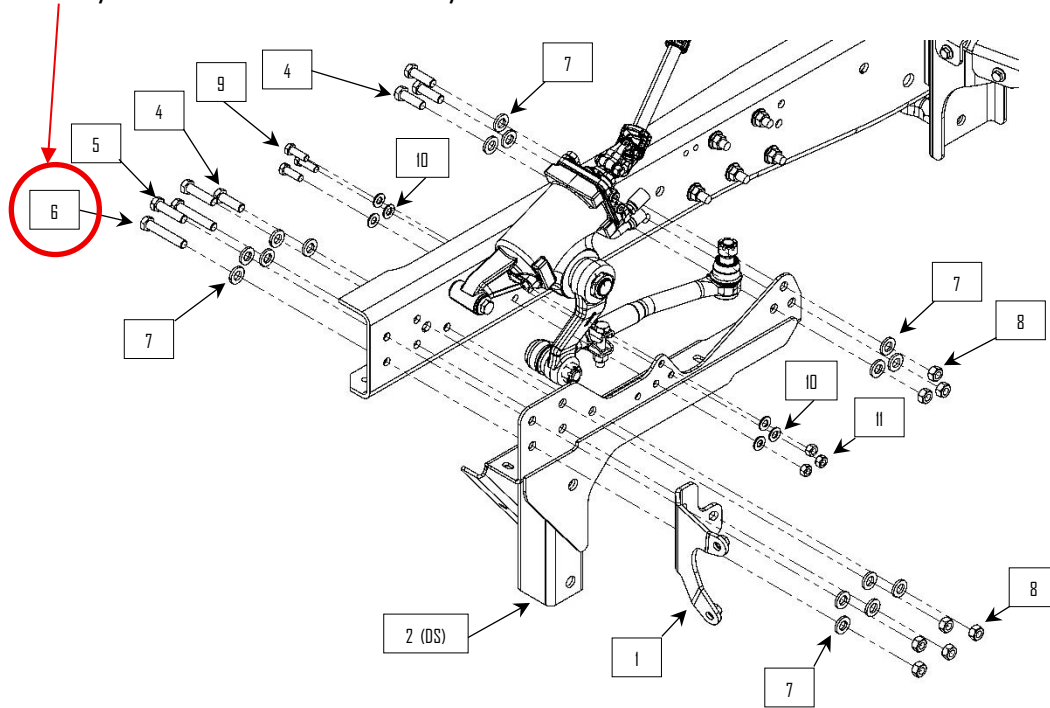

- 2:** Drill out the two smaller holes in the second frame crossmember to 17/32" dia. **NOTE:** On trucks without a factory equipped sway bar. Use the side plate (2) as a jig to drill the three holes located under the steering box. If you have a stock sway bar you will not need to drill these holes.

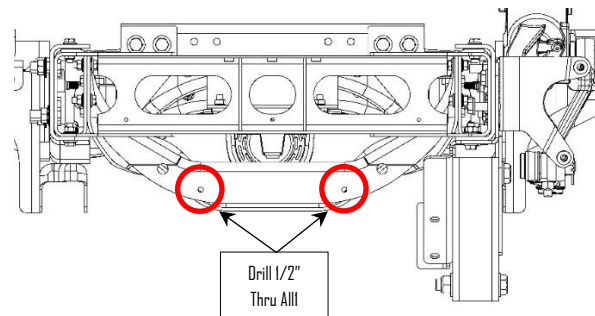
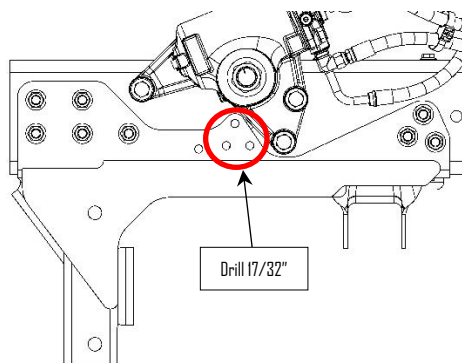

- 3:** Note: the (34) bolts will be connecting the radiator supports below. Start with bolting the panhard bar crossmember (12) into the second frame crossmember. Use 3/4" hardware (18, 19, & 20) in the top hole. (14) is the 10006975 spacer. (13) is the 10006974 spacer.

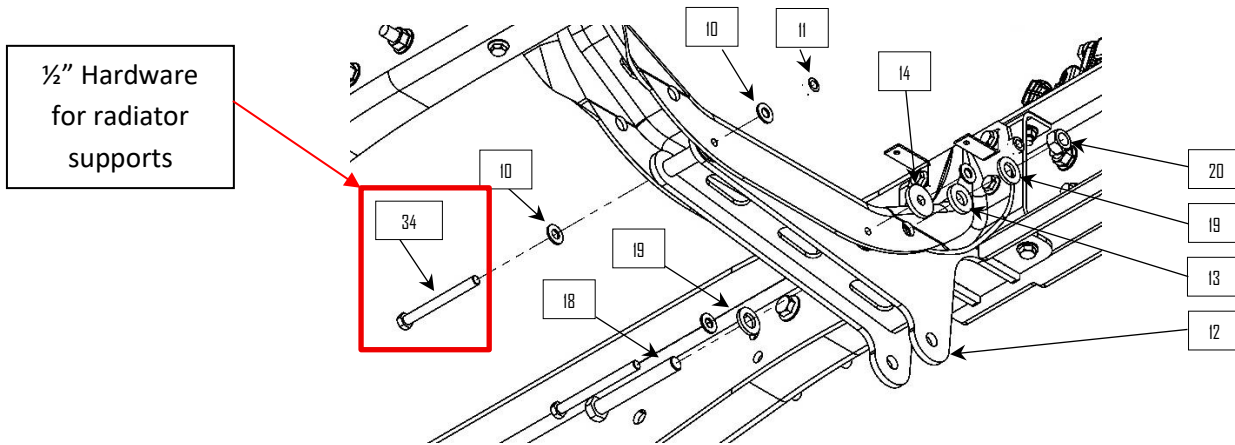

- 4:** Next, Install the lower radiator supports removed in Disassembly *step 7*. On the driver's side use spacer washers (13 & 14) to move the core support brace away from the Panhard bar crossmember. You will need to Drill the driver's side radiator supports need two holes drilled to 1/2" and 3/4". The passenger side will need a 1/2" hole drilled. Then use the 1/2" hardware from above to install the radiator supports to the Panhard bar.

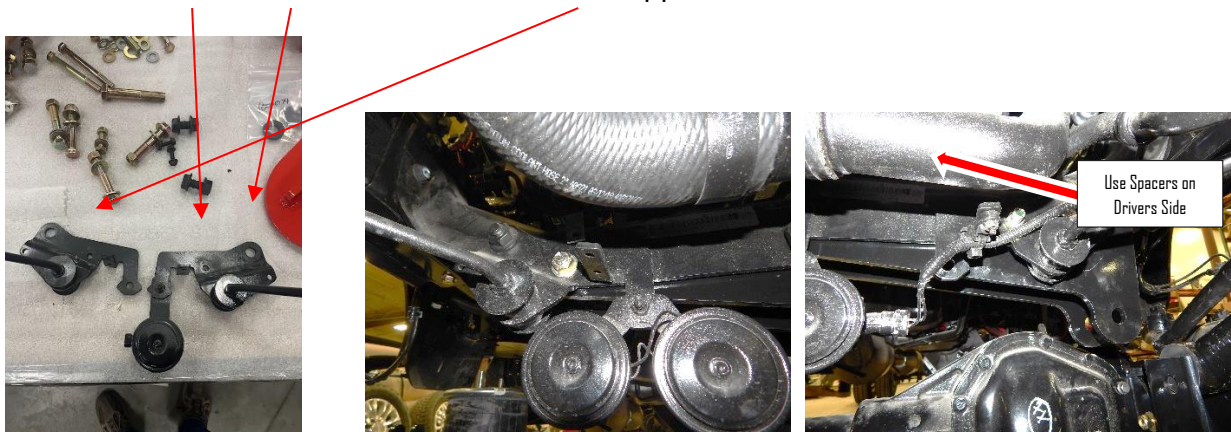

- 5:** Fasten the side plate (2) and the panhard bar crossmember (12) to the bottom frame rail flange using 1/2" hardware (10, 11, 15, & 16).

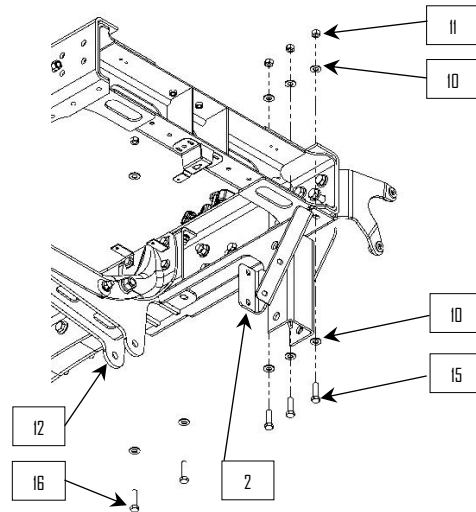

6: Proceed to *Disassembly step 14* and repeat the steps on the opposite frame rail.

7: Realign the forward crossmember with the marks made during disassembly and bolt side plate (3) onto the frame rail using 5/8" hardware (4, 5, 6, 7, & 8). The longest two 5/8" bolts (6) fasten thru the OEM tow hook and the bumper bracket (1).

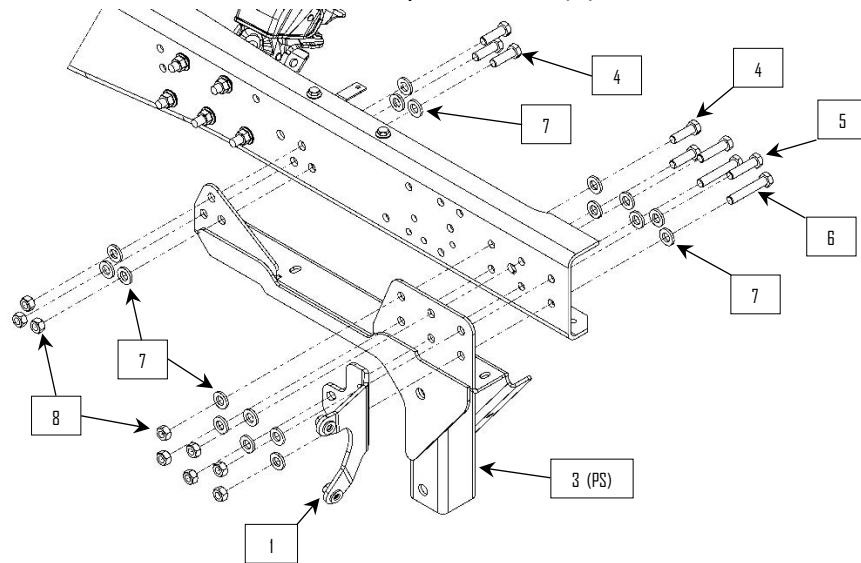

8: Fasten the side plate (3) to the bottom frame rail flange using 1/2" hardware (10, 11, 15, & 16).

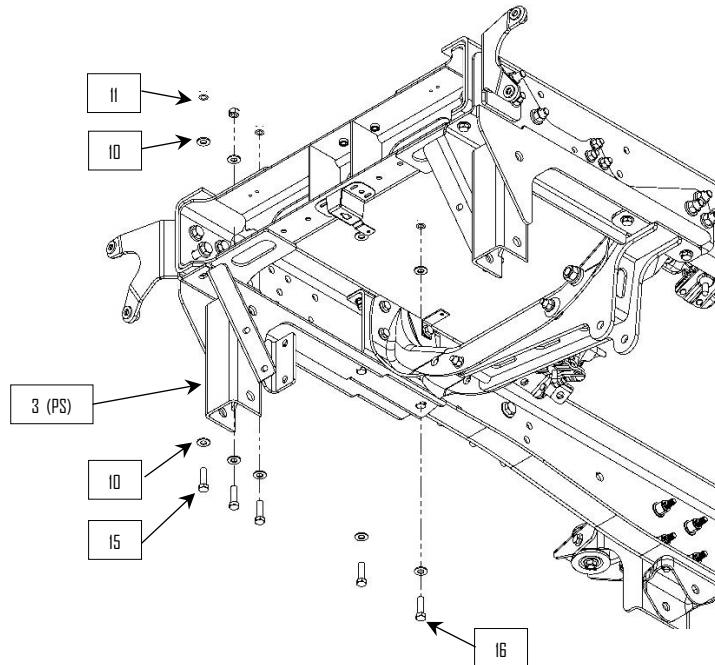

- 9:** Check the frame for square using the reference measurements taken in Disassembly *step* 12. Make any required adjustments, once square snug up the installed hardware.
- 10:** Support the engine and remove the three bolts (Red) shown below from the engine mount.
NOTE: These bolts will be reused when installing the bag plate. **CAUTION:** Only remove these bolts from one side at a time or engine will fall. Once you remove these three bolts insert the lower two back into their factory location and tighten. Once you have those tight, Remove the other two bolts holding the crossmember up (Blue).

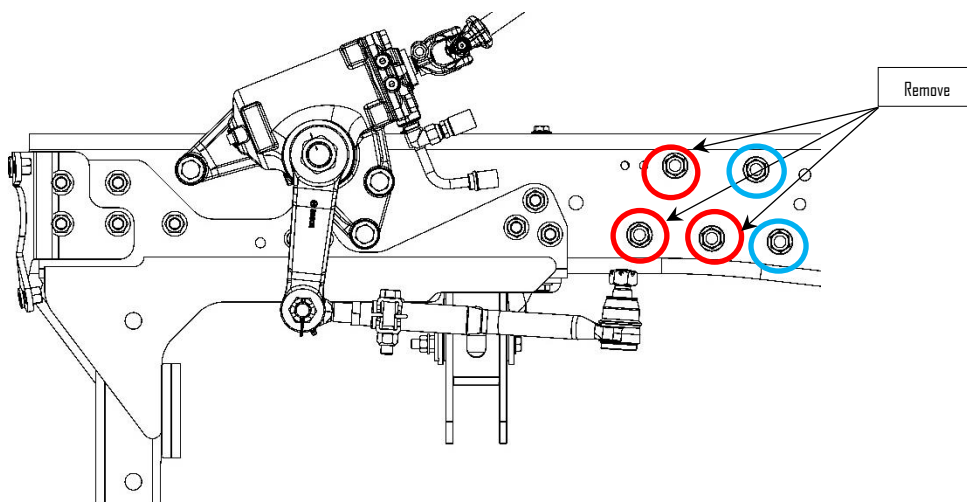

If you have ABS sensor package on your truck, you will have a couple steps to fully complete your kit along with the steps before and after these steps.

You will need to remove the original ABS bracket (Picture Below). Once you have removed the bracket you will need to push the rest of your ABS system to the side and finish installing upper bag mount. Once you have completed this step you will be able to bolt the ABS Bracket you have left on the truck onto the upper bag mount. **Note:** You will need to grind this bolt down to allow room for the rest of the installation.

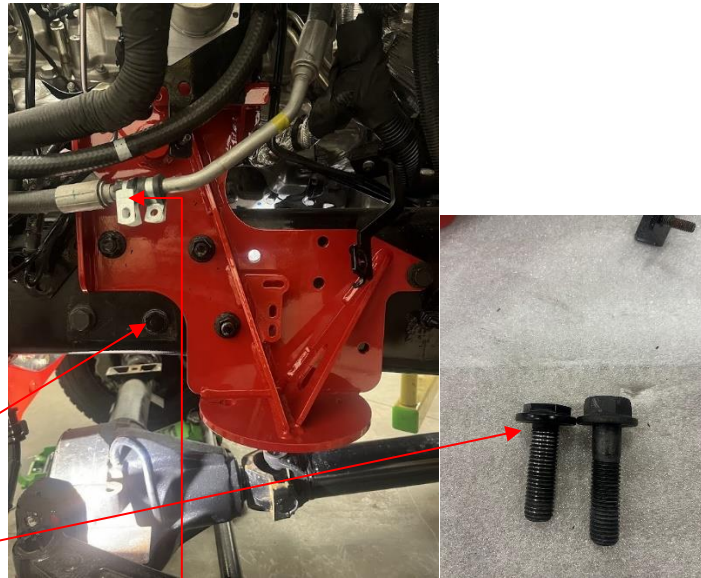

Bolt you grinded down

The rest of the ABS Bracket bolts here on the Upper bag mount

ABS Bracket you will need to remove, won't be used for installation.

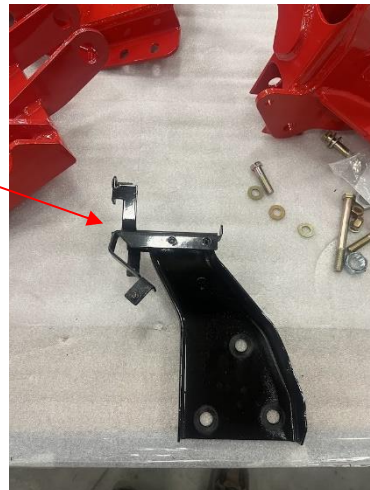

- 11:** Flip the OEM engine mount bolt located directly under the shock mount. **NOTE:** This provides clearance for the shock.

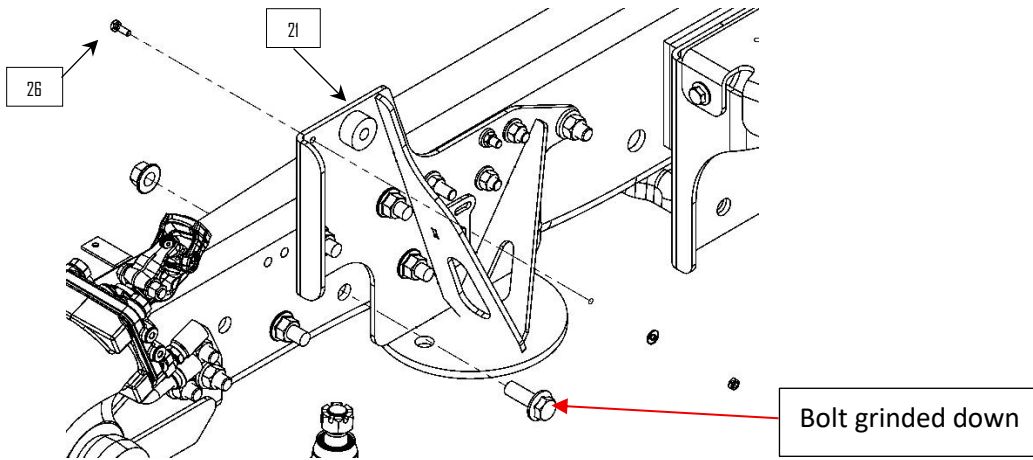

- 12:** Align the upper bag plate (21) on the frame using the OEM engine mount bolts. Use 5/8" hardware (4, 7, & 8) to fasten the rear of the of the bag plate to the frame. Note: When installing the upper bag mount, you need to grind the factory bolt down. This step is above in the ABS Bracket Information page.

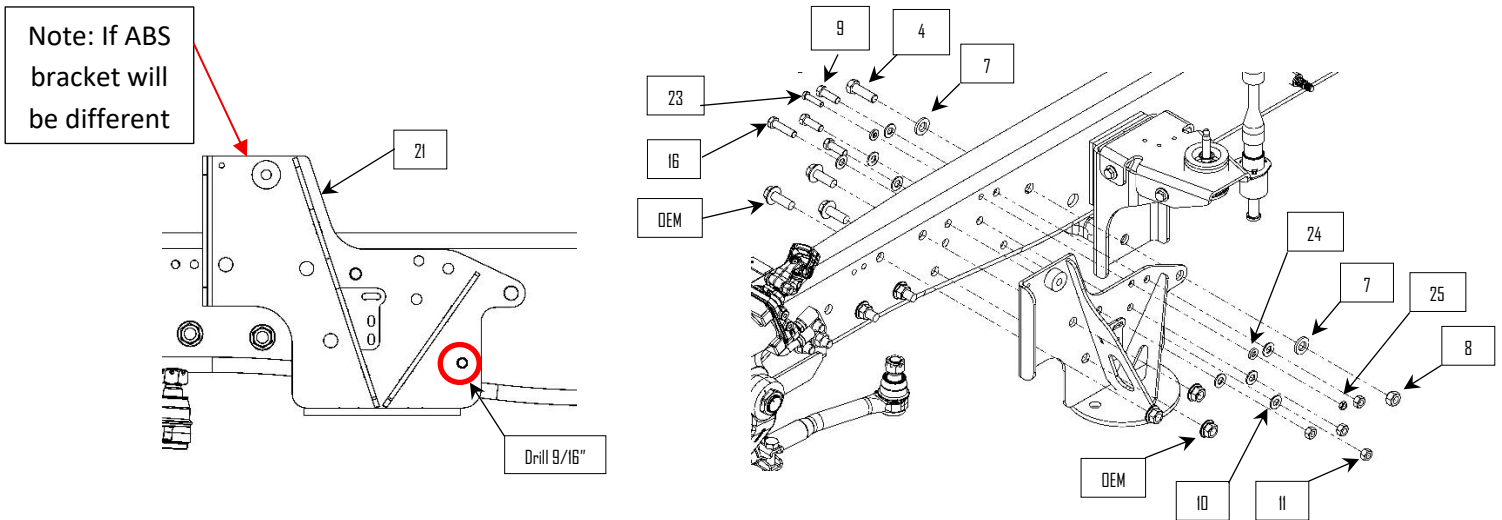

- 13:** Use the upper bag plate as a guide to drill a 9/16" hole in the frame rail. Use 1/2" hardware (9, 10, 11, & 16) to fasten to the frame. **NOTE:** Use the longer 1/2" bolt to reattach the internal cable bracket.
- 14:** Use 3/8" hardware (23, 24, & 25) to reattach the ground cable to the frame.
- 15:** Snug up all upper bag plate (21) hardware.

16: Use 1/4" hardware (26, 27, & 28) to fasten the power steering lines to the back side of the upper bag plate (21).

17: Align the upper bag plate (22) on the frame using the OEM engine mount bolts. Use 5/8" hardware (4, 7, & 8) to fasten the rear of the of the bag plate to the frame.

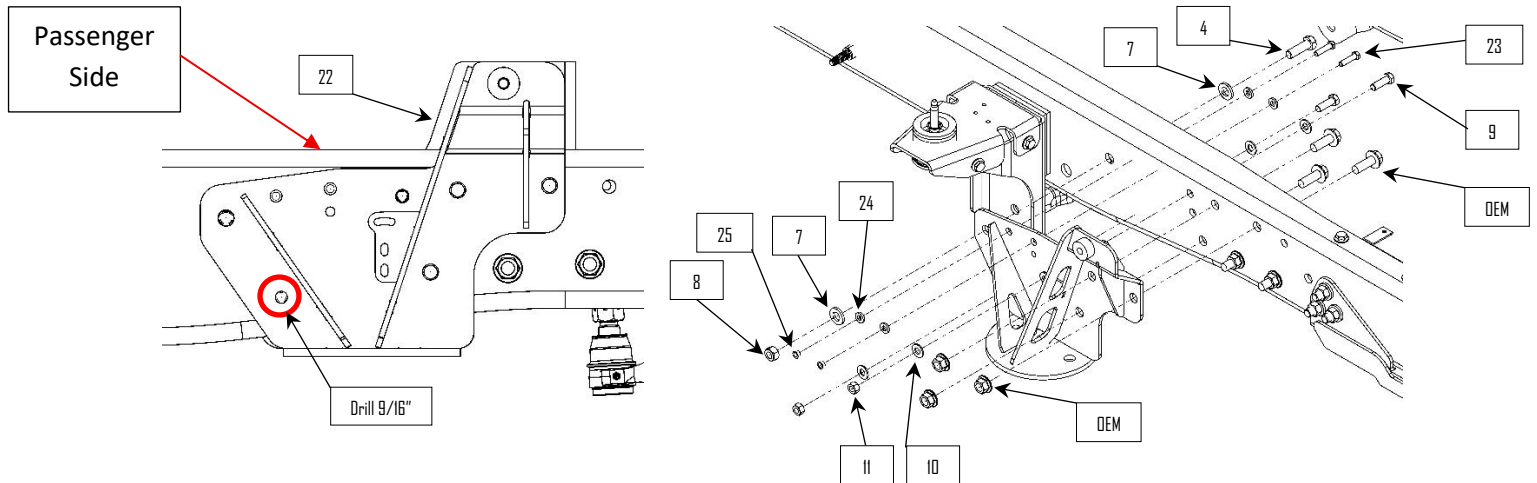

18: Use the upper bag plate as a guide to drill a 9/16" hole in the frame rail. Use 1/2" hardware (9, 10, & 11) to fasten to the frame.

19: Use 3/8" hardware (23, 24, & 25) to reattach the wiring and ground cable to the frame.

20: Position the lower bag mount (29) and axle clamp (30) onto the passenger side of the axle. Both weldments have a pin that when aligned correctly will sit on the spring pad. Use 5/8" hardware (7, 8, & 33) to fasten around the axle. Lower bag mount (29) has a hex shaped hole, use 5/8" hardware (7, 8, & 32) to fasten at this location. **NOTE:** Do not tighten hardware yet.

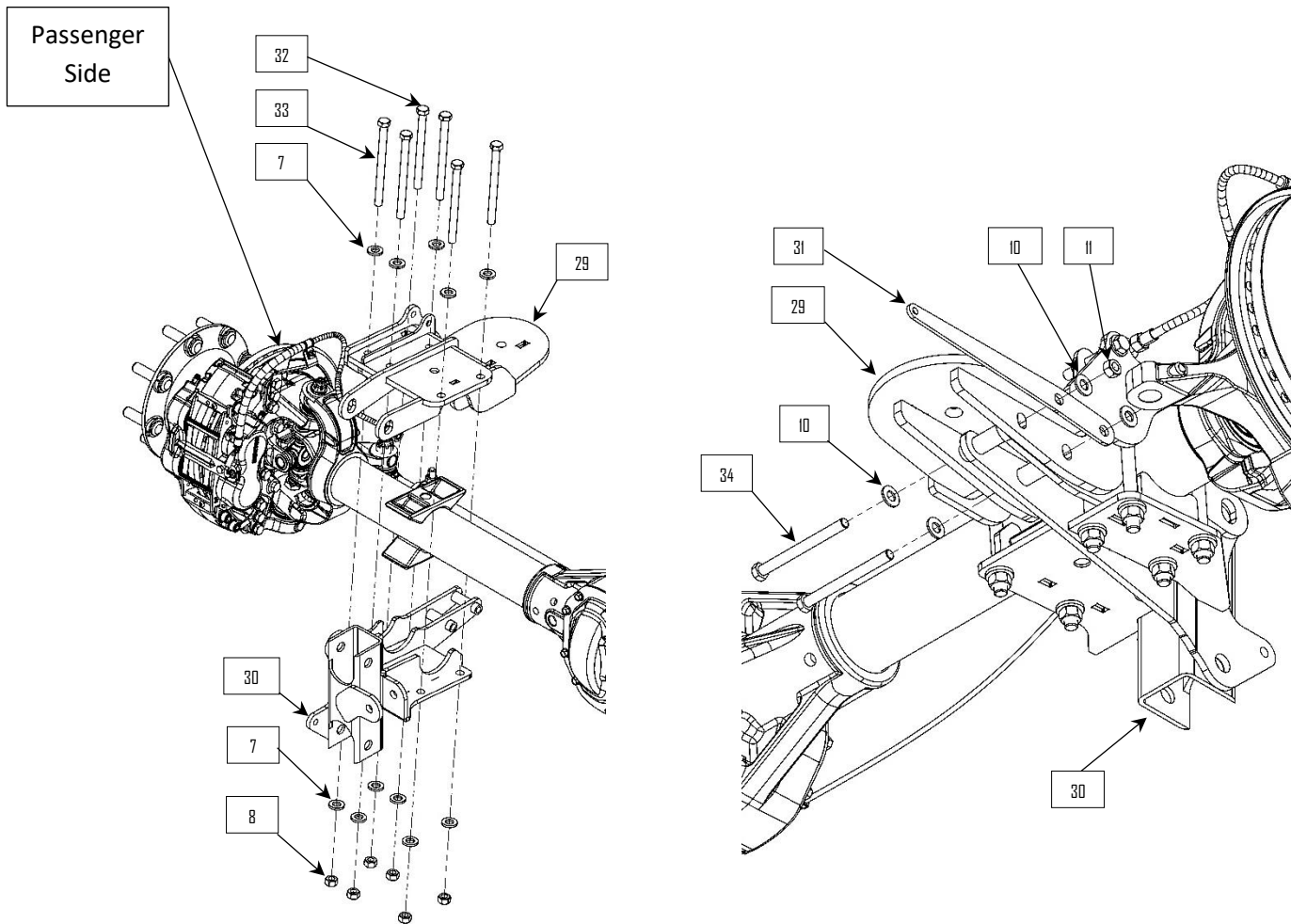

- 21:** Bolt the axle ride height arm (31) to the lower bag plate (29) using 1/2" hardware (10, 11, & 34). **NOTE:** Do not tighten hardware yet.
- 22:** Position the lower bag mount (35) and axle clamp (36) onto the driver side of the axle. Align the pin on lower bag mount (35) with the spring pad on the axle. Use 5/8" hardware (7, 8, & 33) to fasten around the axle. Lower bag mount (35) has three hex shaped holes, use 5/8" hardware (7, 8, & 32) to fasten at these locations. Use 5/8" hardware (7 & 38) too bolt to the top of the differential casting. **NOTE:** Do not tighten hardware yet.
- 23:** Fasten the differential bracket (37) to the differential cover, reuse the factory differential cover bolts.

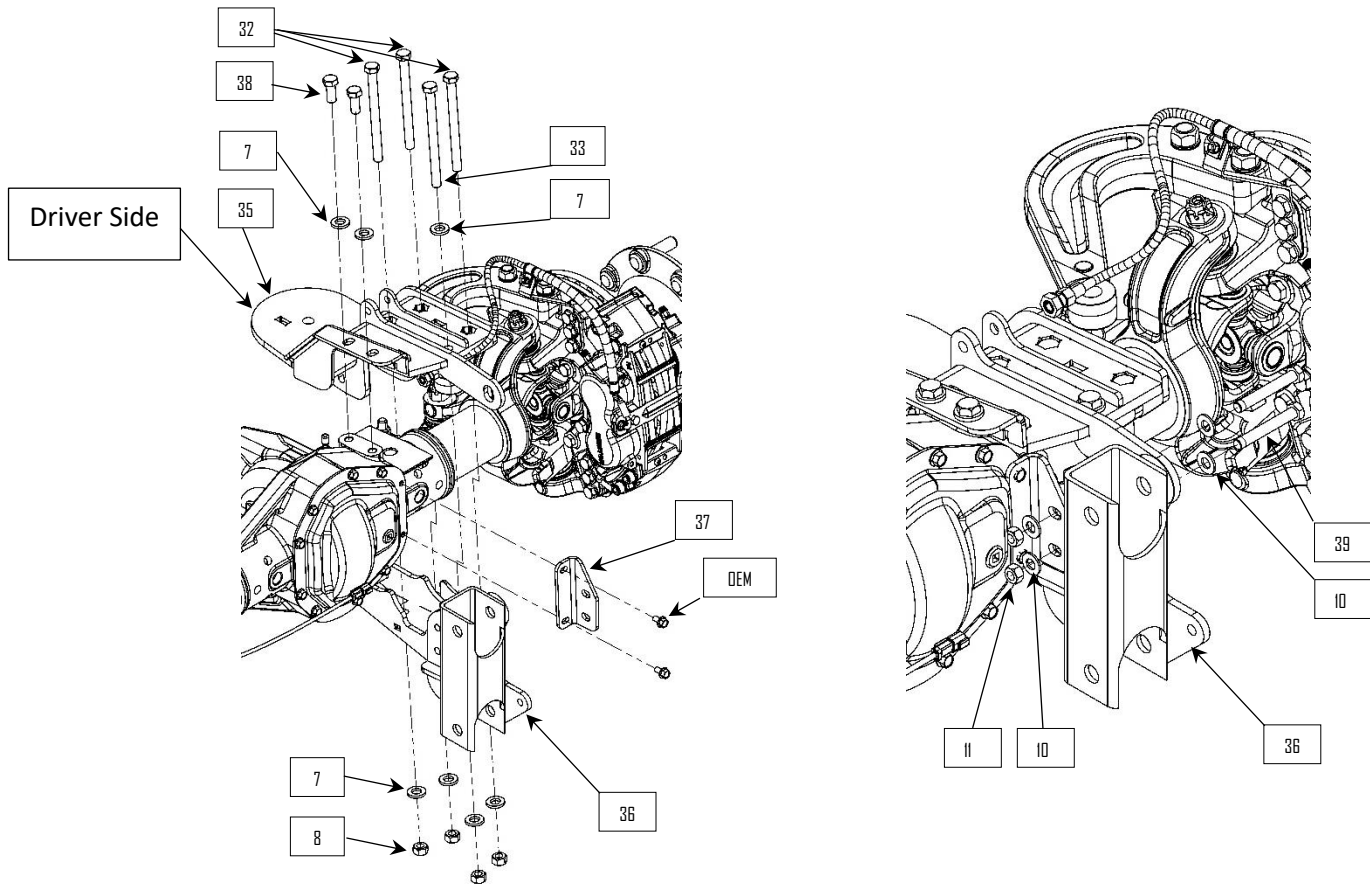

24: Use 1/2" hardware (10, 11, & 39) to fasten the axle clamp (36) to the differential bracket (37).

25: Bolt the axle ride height arm (31) to the lower bag plate (35) using 1/2" hardware (10, 11, & 34). **NOTE:** Do not tighten hardware yet.

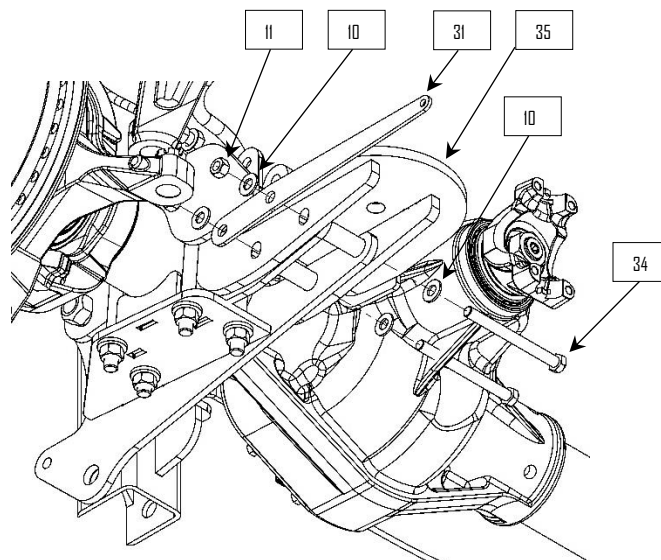

26: Find the trailing arm bars. Adjust the knuckles equally until the gap between the knuckles equals 9". Insert 5/8"-18x 3 pinch bolts, two flat washers, and lock nut into the cast knuckles but do not tighten.

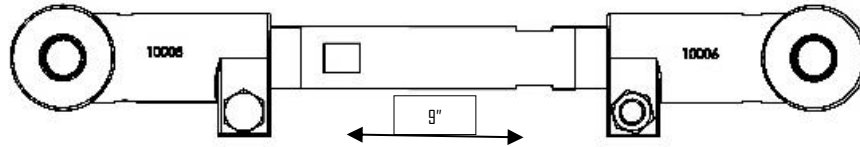

27: Use 7/8" hardware (48, 49, & 50) to install the upper trailing arm assemblies into the lower bag plates (30 or 36). Note: Make sure the front top pinch bolt on both sides of the truck is facing the opposite direction from the rest.

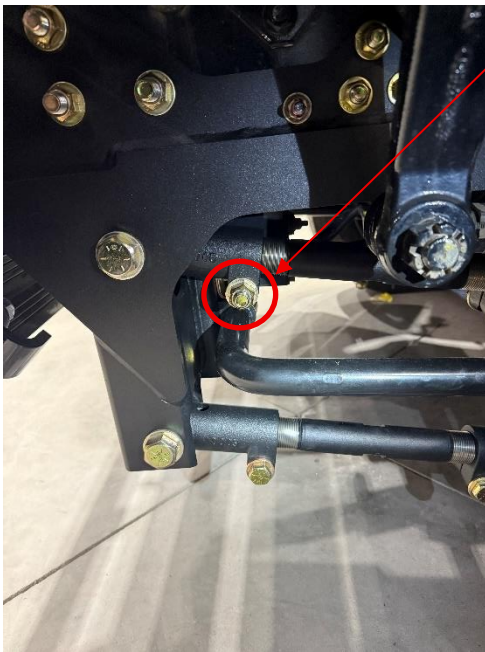

28: Once aligned and bolted together tighten down all axle hardware.

29: Use 7/8" hardware (49, 50, & 51) to install the lower trailing arm assemblies into the lower bag plates (30 & 36). **NOTE:** Install the upper trailing arm bar the same direction as the lower bar, this will make adjustments easier.

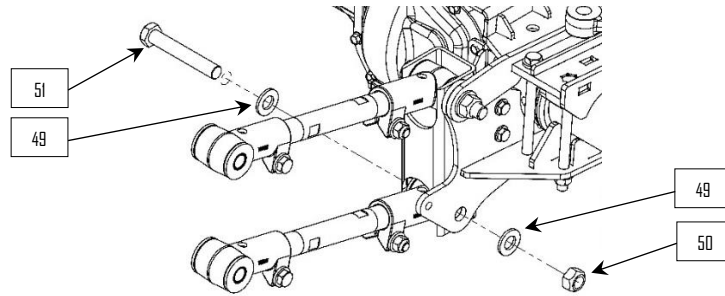

30: Bolt the upper and lower trailing arm assembly into the side plate (2 or 3) using 7/8" hardware (49, 50, 51, & 52). **Torque:** 7/8"-14 trailing arm bolts should be torqued to 300ft-lb.

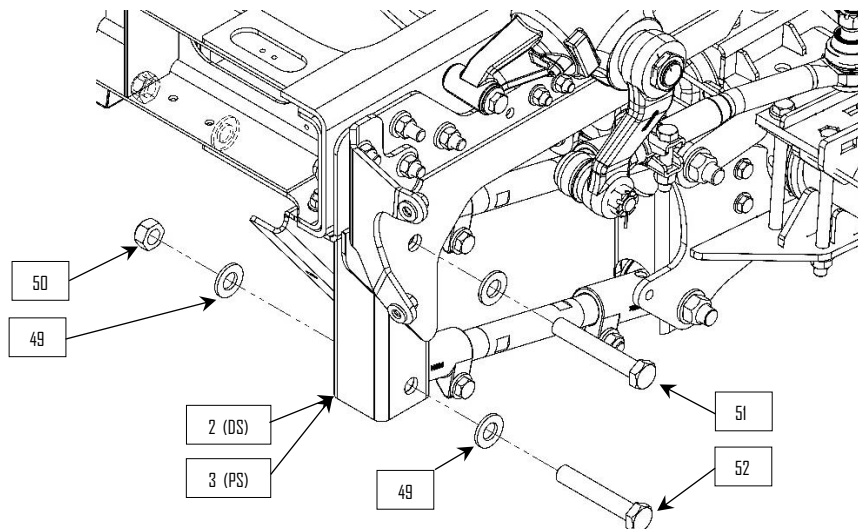

31: Fasten the steering stabilizer mount (53) and clamp (54) to the axle. Use OEM differential cover bolts to position the clamp (54). Use 7/16" hardware (55, 56, & 57) to fasten around the axle.

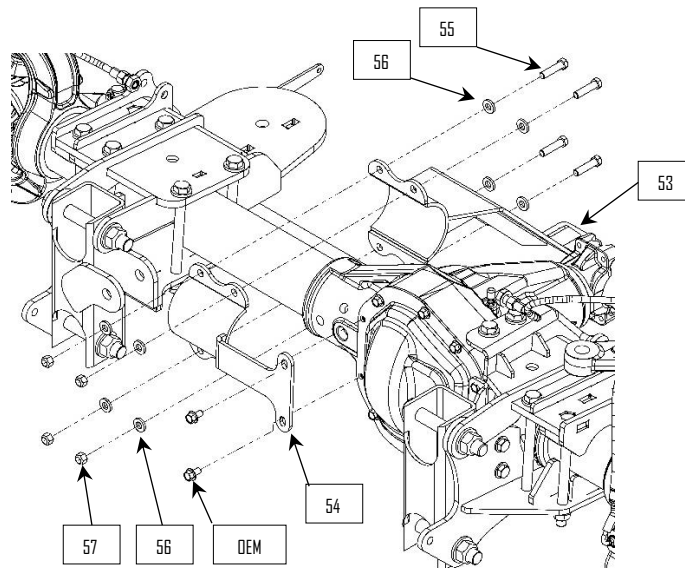

32: Install the tie rod brackets (58 & 59) use the OEM pinch bolts and 1/2" hardware (10, 11, & 62).

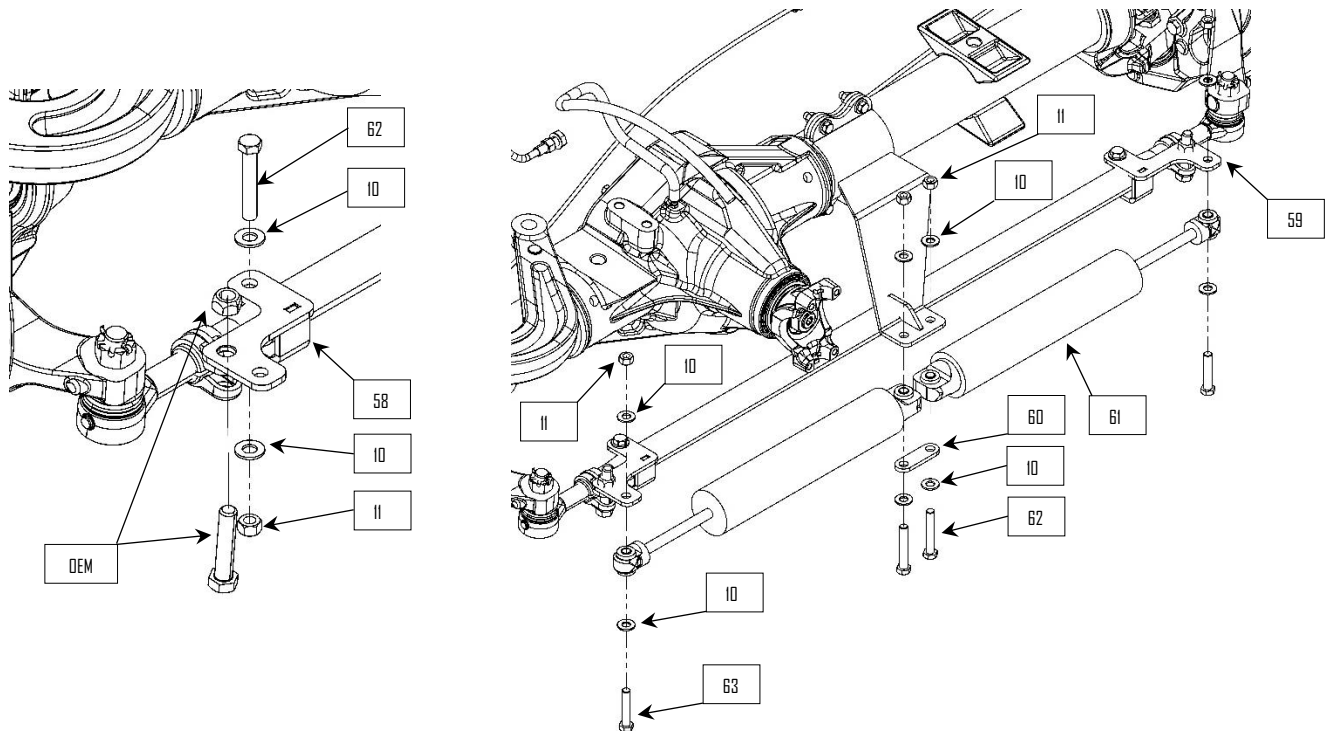

33: Fasten the Raptor monotube shocks (61) to the tie rod brackets (58 & 59) and the stabilizer mount (53) using 1/2" hardware (10, 11, 63, & 62).

34: Thread 7/8" jam nuts (67 & 68) onto the rebuildable heims (65 & 66). Thread the heims into the panhard bar (64). Set the center to center distance at 22-3/8", but do not tighten the jam nuts yet.

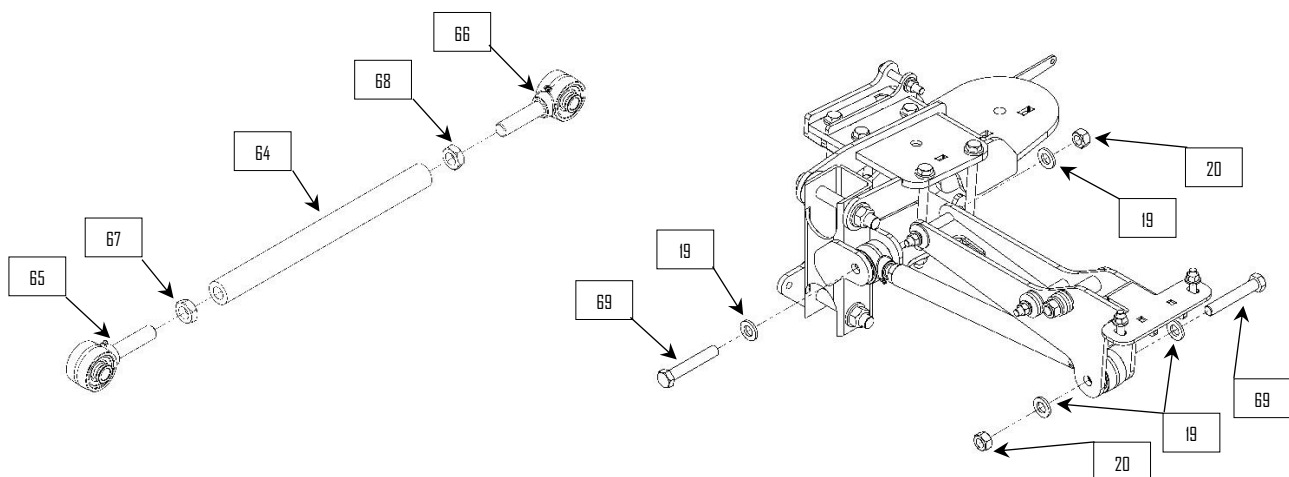

35: Install the panhard bar assembly, use 3/4" hardware (19, 20, & 69) **NOTE:** Position grease zerks down. **Torque:** 3/4"-16 panhard bar bolts should be torqued to 150ft-lb.

36: Install air bags (70). Use 1/2" hardware (10, 71, & 73) and 3/4" hardware (19, 72, & 75) to fasten the bags to the upper bag plates (21 & 22). Use 1/2"-13x 2-1/4" to fasten the lower onto the bottom of the bag. **NOTE:** The 90° air fitting (76) should point toward the back of the truck.

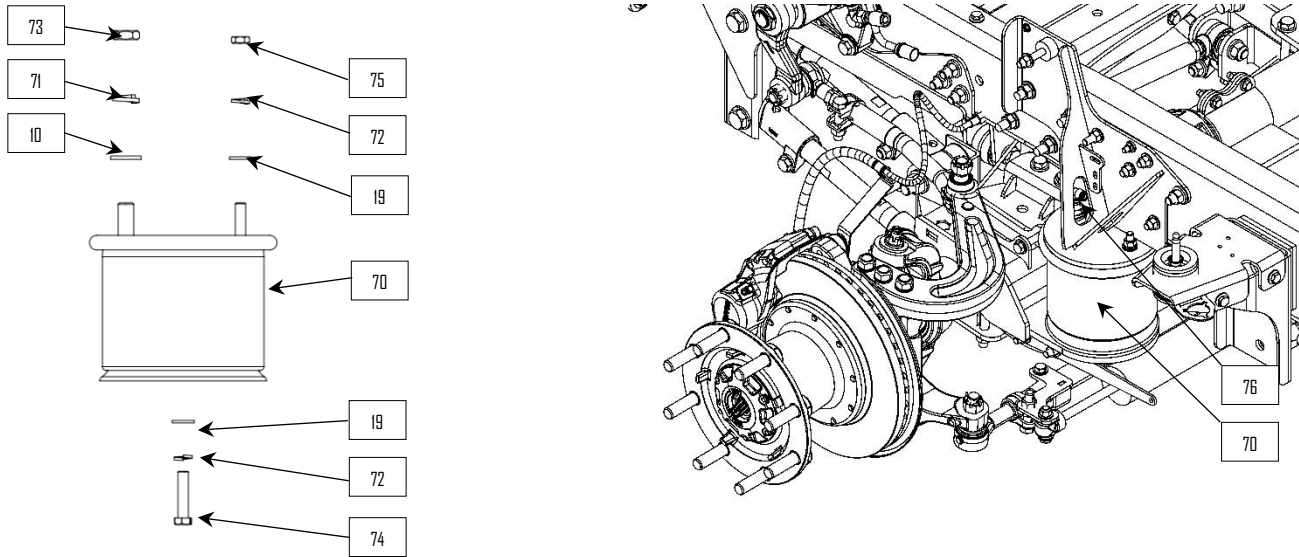

37: Grease the sway bar bushings (77) and install onto sway bar (78). Install the d-rings (79) over the bushings (77) and fasten to the side plates (2 & 3) using 3/8" hardware (24, 25, & 80).

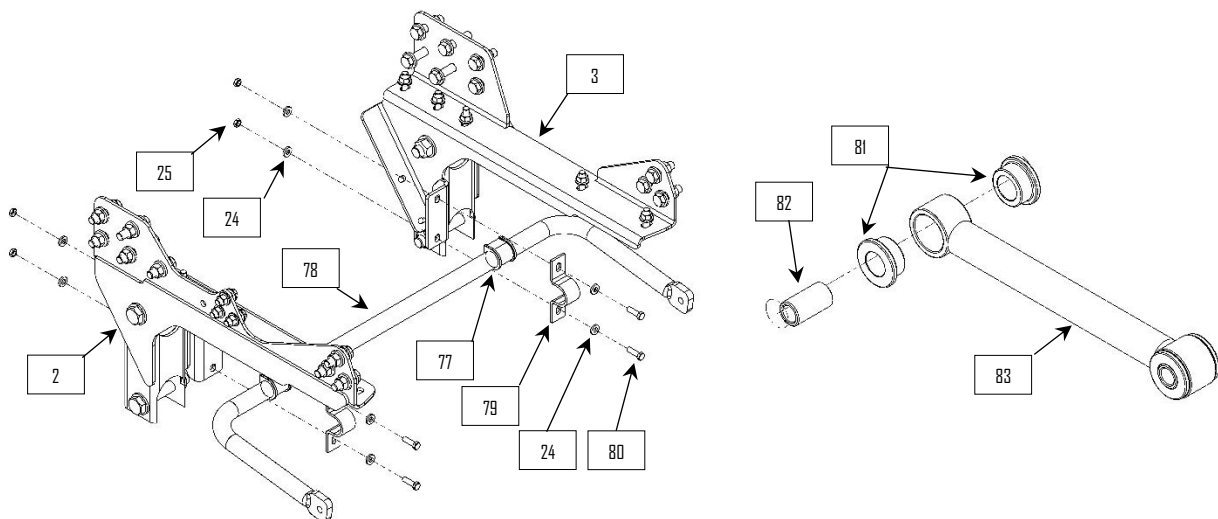

38: Press poly hat bushings (81) and sleeve (82) into both ends of the sway bar end links (83).

- 39:** Install the end link assemblies using 1/2" hardware (10, 13, 39, & 62). Install the end link washers (84) on the open side of the end link (83). **NOTE:** Bolts must point outward to clear the trailing arms.

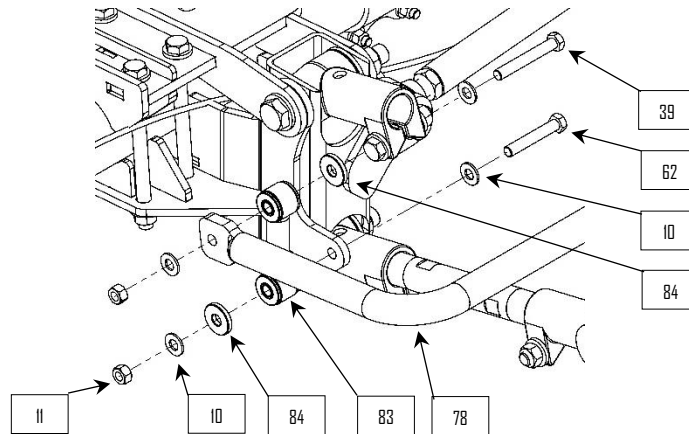

- 40:** Bolt the skid plate (85) between the side plate (2 & 3) using 3/8" hardware (24, 25, & 80).

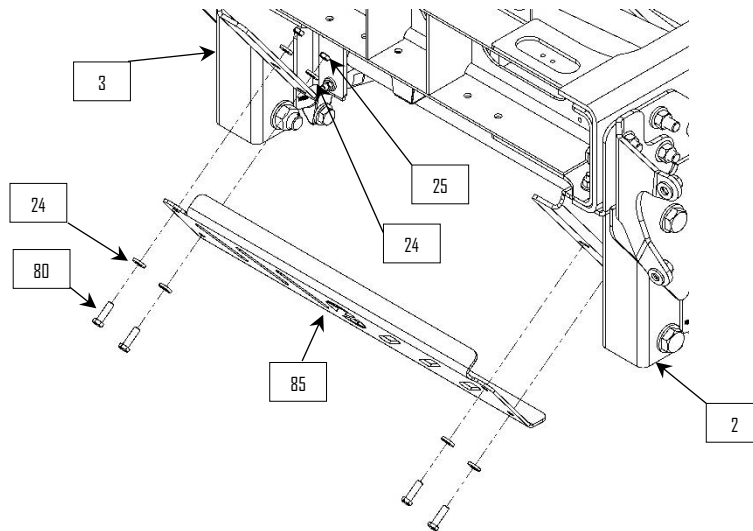

- 41:** Use the piggyback clamp (87) and socket head cap screw (88) to mount the shock reservoir to the main body of the shock (86). Note: Shock part number is 10007160.

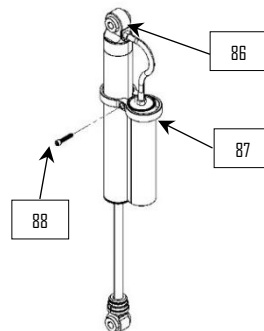

42: Note: ABS Models ONLY! When installing the kit, if you have the ABS version of the truck. Mounting the reservoir for the shock will be different. First, locate the reservoir relocation bracket and mount the clamps to the bracket using $\frac{1}{4}$ "-20 cap screws. Once you have the reservoir mounted in the bracket (Not installed on the truck yet) Tighten the bolts and grind off the extra length of bolt that is sticking through. Then, proceed to step 43 to install the body of the shock. If you have ABS after installing the shock, install the mount on top of the factory cab mount using the factory hardware.

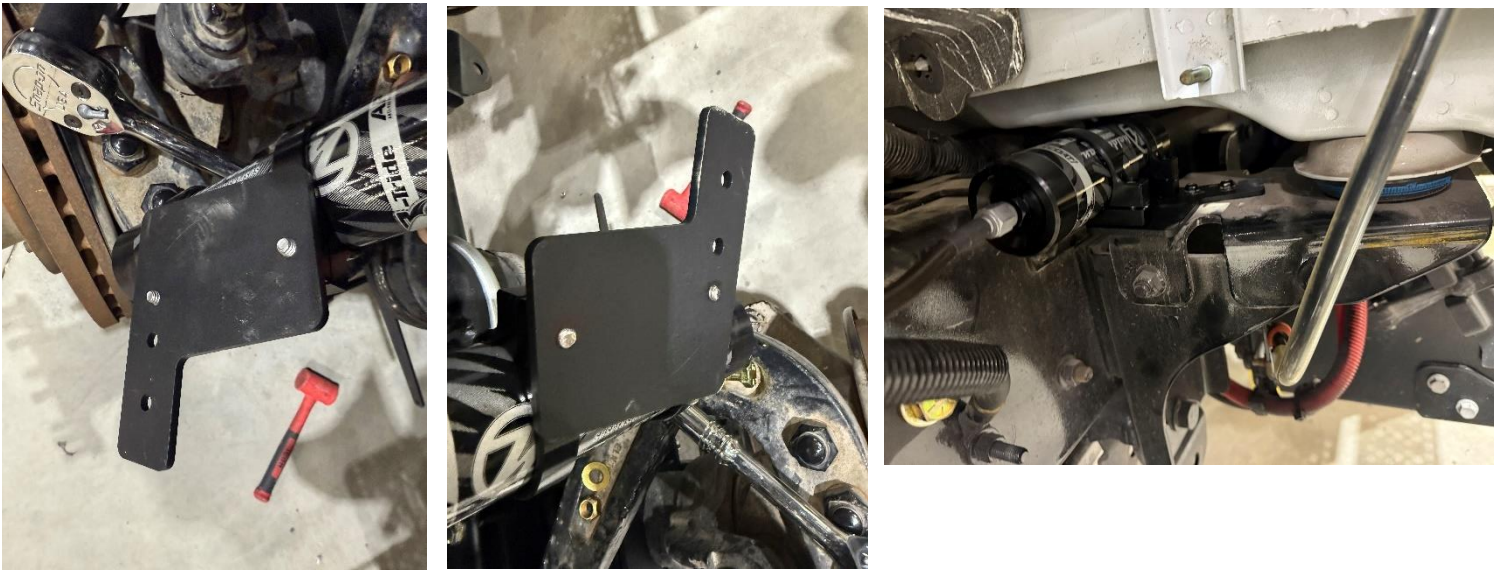

43: Use $\frac{1}{2}$ " hardware (10, 11, & 39) to mount the shocks (86). **NOTE:** Mount the reservoir as high as possible and orient it outward. Check that the reservoir will not contact any steering components or snag any hoses or lines as the suspension & steering travel thru their full sweep.

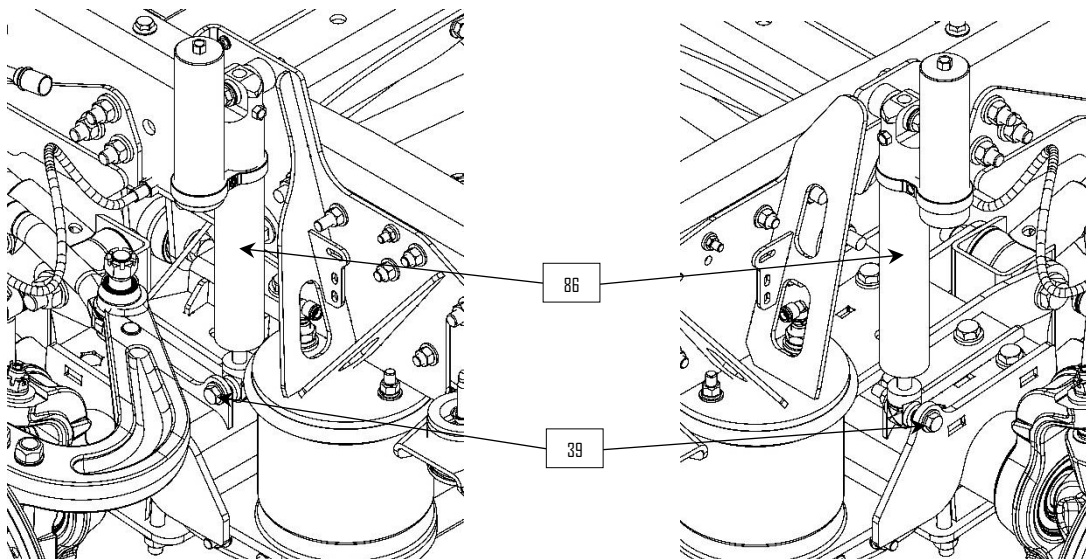

44: Refer to the *Air Controls Instruction Manual* for directions on plumbing and installing the compressor.

45: The height control sensors mount to the upper bag plates (21 & 22).

46: Inflate the airbags (70) to 7-3/4" this is the designed ride height for this kit.

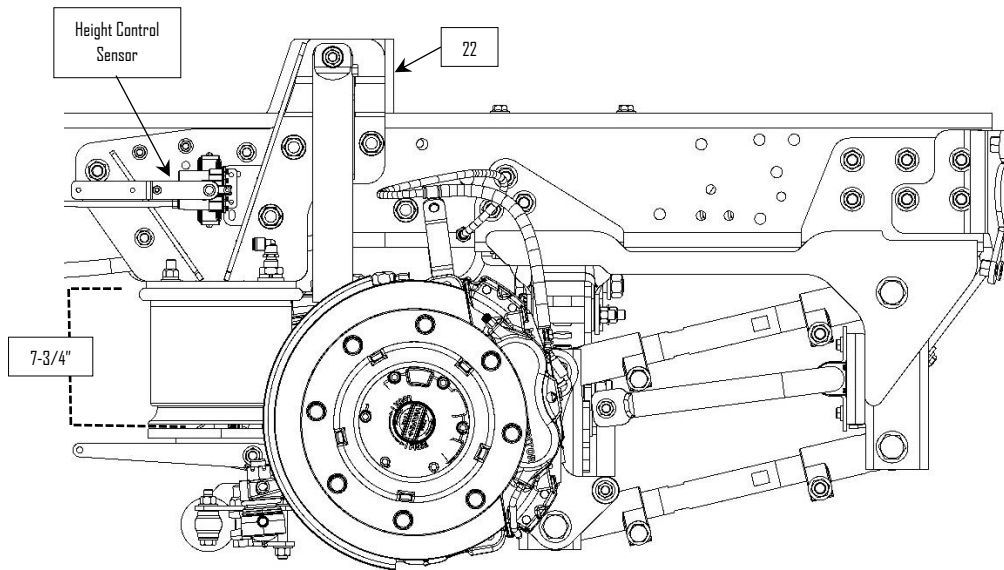

47: Reinstall the front tires.

48: With the truck sitting at ride height check pinion angle and wheelbase measurements. Adjust the trailing arm bars as needed to set the front axle back to factory position. Check that the axle is centered under the truck and adjust the panhard bar as required. **NOTE:** Refer to notes taken in Disassembly steps 1 & 2.

49: Torque all fasteners to the specifications in the chart below, unless noted elsewhere in the instructions.

Bolt Size	Grade 5 Torque	Grade 8 Torque
1/4"-20	8 ft-lb	12 ft-lb
3/8"-16	31 ft-lb	44 ft-lb
3/8"-24	35 ft-lb	49 ft-lb
1/2"-13	75 ft-lb	106 ft-lb
1/2"-20	85ft-lb	120 ft-lb
9/16"-18	121 ft-lb	171 ft-lb

5/8"-11	150 <i>ft-lb</i>	212 <i>ft-lb</i>
5/8"-18	170 <i>ft-lb</i>	240 <i>ft-lb</i>
3/4"-16	297 <i>ft-lb</i>	420 <i>ft-lb</i>
7/8"-14	474 <i>ft-lb</i>	669 <i>ft-lb</i>

- 50:** Sweep the suspension and the steering thru the full range of motion and check that no components are binding, colliding, or rubbing.
- 51:** Reinstall the front bumper.
- 52:** Trim the plastic inner fenders to clear the shock mounts and the height control valves.

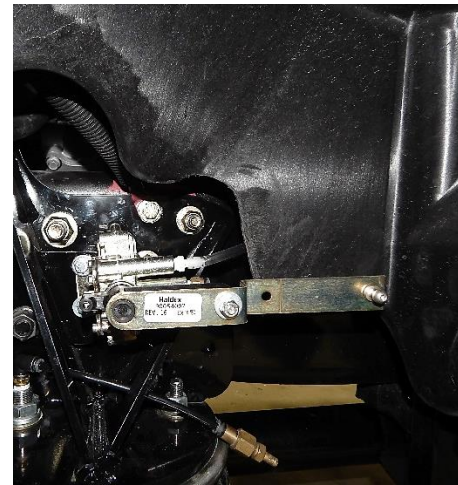
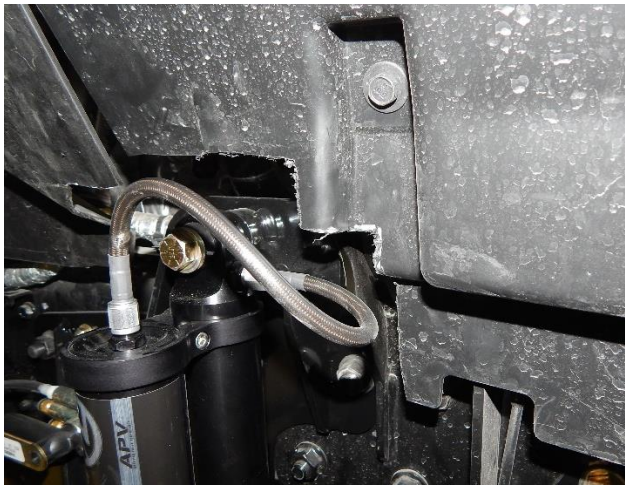

- 53:** The truck is now ready to test drive. If the truck pulls to one direction, shorten the opposite side trailing arms one turn and test drive again. Repeat until pull is eliminated. Always check the pinion angle and bag heights after making any trailing arm adjustments.
- 54:** After test driving check all fasteners to make sure nothing has worked loose. Inspect suspension for signs that any component maybe binding, colliding, or rubbing, reposition if required.
- 55:** Use soapy water to check air components and lines for any leaks.

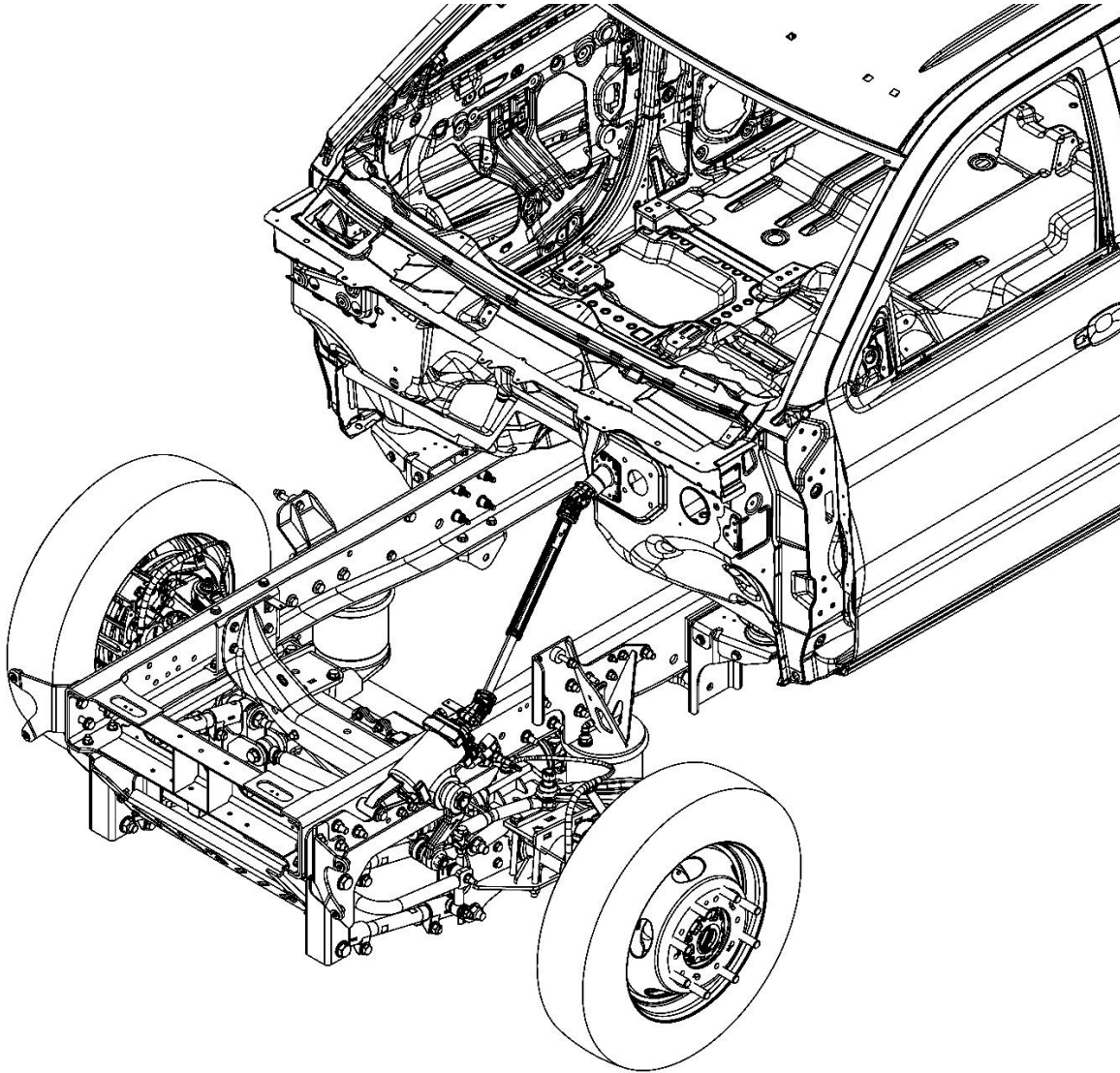

Parts Key

Item Number	Part Number	Description
1		OEM Bumper Bracket
2	10006735	Weldment – Trailing Arm Side Plate (DS)
3	10006736	Weldment – Trailing Arm Side Plate (PS)
4	12409	Hex Bolt: 5/8" -18 x 2"
5	12415	Hex Bolt: 5/8" -18 x 2-1/2"
6	12423	Hex Bolt: 5/8" -18 x 3-1/2"
7	13026	Flat Washer: 5/8"
8	13126	Lock Nut: 5/8" -18

9	12007	Hex Bolt: 1/2"-20 x 1-1/2"
10	13024	Flat Washer: 1/2"
11	13124	Lock Nut: 1/2"-20
12	10006734	Weldment – Panhard Bar Crossmember
13	10006974	Plate – 1/4" – Core Support Bracket (3/4")
14	10006975	Plate – 1/4" – Core Support Bracket (1/2")
15	12009	Hex Bolt: 1/2"-20 x 1-3/4"
16	12011	Hex Bolt: 1/2"-20 x 2"
17	12037	Hex Bolt: 1/2"-20 x 5"
18	12539	Hex Bolt: 3/4"-16 x 5-1/2"
19	13028	Flat Washer: 3/4"
20	13128	Lock Nut: 3/4"-16
21	10006737	Weldment – Upper Bag Plate (DS)
22	10006741	Weldment – Upper Bag Plate (PS)
23	12217	Hex Bolt: 3/8"-24 x 1-1/2"
24	13022	Flat Washer: 3/8"
25	13122	Lock Nut: 3/8"-24
26	12108	Hex Bolt: 1/4"-20 x 3/4"
27	13000	Flat Washer: 1/4"
28	13100	Lock Nut: 1/4"-20
29	10006781	Weldment – Lower Bag Mount (PS)
30	10006780	Weldment – Axle Clamp (PS)
31	10006923	Plate – 7ga – Axle Ride Height Arm
32	12455	Hex Bolt: 5/8"-18 x 7-1/2"
33	12459	Hex Bolt: 5/8"-18 x 8"
34	12041	Hex Bolt: 1/2"-20 x 5-1/2"
35	10006773	Weldment – Lower Bag Plate (DS)
36	10006772	Weldment – Axle Clamp (DS)
37	10006763	Plate – 1/4" – Differential Bracket
38	12404	Hex Bolt: 5/8"-11 x 1-1/2"
39	12025	Hex Bolt: 1/2"-20 x 3-1/2"
40	80136	Poly Hat Bushing – 1.8"OD x 1-1/8" ID
41	20093	Knuckle Sleeve – 1-1/8"OD x 7/8" ID
42	10005	Cast Trailing Arm Knuckle (RHT)
43	10006	Cast Trailing Arm Knuckle (LHT)
44	52114.5	Trailing Arm Bar – 14.5"
45	12420	Hex Bolt: 5/8"-11 x 3/4"
46	13106	Lock Nut: 5/8"-11
47	12637	Hex Bolt: 7/8"-14 x 6"
48	12641	Hex Bolt: 7/8"-14 x 6-1/2"
49	13030	Flat Washer: 7/8"
50	13130	Lock Nut: 7/8"-14
51	12633	Hex Bolt: 7/8"-14 x 5-1/2"
52	12629	Hex Bolt: 7/8"-14 x 5"
53	10007026	Weldment – Steering Stabilizer Mount
54	10007033	Weldment – Steering Stabilizer Clamp
55	13413	Hex Bolt: 7/16"-20 x 1-3/4"
56	13023	Flat Washer: 7/16"
57	13123	Lock Nut: 7/16"-20

58	10007034	Weldment – Stabilizer Tie Rod Bracket (DS)
59	10007037	Weldment – Stabilizer Tie Rod Bracket (PS)
60	20227	Plate – 1/4" – Stabilizer Shock Strap
61	10003382	Raptor Shock – Monotube Twin Eyelet
62	12021	Hex Bolt: 1/2"-20 x 3"
63	12017	Hex Bolt: 1/2"-20 x 2-1/2"
64	10006928	Panhard Bar – 17"
65	80281	Rebuildable Heim – 3/4" Bolt – 7/8"-14 RHT
66	80282	Rebuildable Heim – 3/4" Bolt – 7/8"-14 LHT
67	13210	Jam Nut: 7/8"-14 RHT
68	13211	Jam Nut: 7/8"-14 LHT
69	12533	Hex Bolt: 3/4"-16 x 4-1/2"
70	80012-5770	Air Bag - 5770
71	13050	Split Lock Washer: 1/2"
72	13056	Split Lock Washer: 3/4"
73	13144	Hex Nut: 1/2"-13
74	13168	Hex Nut: 3/4"-16
75	13208	Jam Nut: 3/4"-16
76	80168	Air Fitting – 90° 1/4" NPT to 3/8" Tube
77	80255	Sway Bar Bushing – 1-3/8" ID
78	80288	Sway Bar – 1-3/8" OD
79	80271	Sway Bar D-Ring – 4" Bolt Spacing
80	12213	Hex Bolt: 3/8"-24 x 1-1/4"
81	80134	Poly Hat Bushing: 1-1/8" OD x 3/4" ID
82	11550	End Link Sleeve – 3/4" OD x 1/2" ID
83	10006787	Weldment – End Link – 4.5"
84	11551	Plate – 1/4" End Link Washer
85	10006681	Plate – 7ga – Skid Plate
86	10007160	Raptor Shock – Remote Reservoir
87	80253	Piggyback Clamp Bracket
88	13502	Socket Head Cap Screw: 1/4"-20 x 1-1/4"

Notes

Contact Information

- Kelderman Manufacturing appreciates your business. We strive to meet the needs of our customers by providing the highest quality products. If you have any questions concerning our products please call or email us at the following:

**2686 Highway 92
Oskaloosa, Iowa 52577**

Phone: (641) 673-5396

Fax: (641) 673-4168

Email: info@kelderman.com



kelderman
