

INSTALL INSTRUCTIONS

STOCK HEIGHT 4-LINK REAR 2019+ CHEVROLET 4500-6500



KIT # 10040696

kelderman



KELDERMAN MANUFACTURING

2686 HIGHWAY 92 EAST OSKALOOSA, IOWA 52577

INFO@KELDERMAN.COM 1-800-334-6150

TABLE OF CONTENTS

- ◆ KIT NUMBERS.....(3)
- ◆ INTRODUCTION.....(4)
- ◆ SAFETY.....(5)
- ◆ PRODUCT OWNER RESPONSIBILITIES.....(6)
- ◆ DISASSEMBLY.....(7-11)
- ◆ KIT INSTALLATION.....(12-31)
- ◆ KIT DRAWINGS.....(32-33)
- ◆ NOTES.....(34)
- ◆ CONTACT INFORMATION.....(35)

KIT NUMBERS

- THIS INSTALLATION MANUAL COVERS THE FOLLOWING AIR RIDE KITS.

KIT NUMBER	DESCRIPTION
10040696	2019+ CHEVROLET 4500/5500/6500 (J27) - 4-LINK REAR - STOCK HEIGHT - BOTH AVAILABLE AXLES



INTRODUCTION

IMPORTANT

- ◆ IT IS IMPORTANT THAT THE ENTIRE INSTALLATION INSTRUCTIONS BE READ THOROUGHLY BEFORE PROCEEDING WITH INSTALLATION.
- ◆ IF YOUR KIT WAS ORDERED RAW, OPEN EVERY BOX AND LOCATE ALL PARTS. THERE ARE SEVERAL SMALLER BUSHING PIECES AND BOLTS THAT ARE PACKAGED SEPARATELY INSIDE THE MAIN BOX.

PRODUCT INSTALLER RESPONSIBILITIES

- ◆ INSTALLER IS RESPONSIBLE FOR INSTALLING THIS PRODUCT IN ACCORDANCE WITH KELDERMAN MFG. INC. SPECIFICATIONS AND INSTALLATION INSTRUCTIONS.
- ◆ INSTALLER IS RESPONSIBLE FOR PROVIDING PROPER INSTALLATION OF VEHICLE COMPONENTS AND ATTACHMENTS AS WELL AS REQUIRED OR NECESSARY CLEARANCE FOR SUSPENSION COMPONENTS, AXLES, WHEELS, TIRES, AND OTHER VEHICLE COMPONENTS TO ENSURE A SAFE AND SOUND INSTALLATION AND OPERATION OF THIS PRODUCT.

DEFINITION OF TERMS

- ◆ **WARNING:** INDICATES A POTENTIALLY HAZARDOUS SITUATION WHICH, IF NOT AVOIDED, COULD RESULT IN DEATH OR SERIOUS INJURY.
- ◆ **CAUTION:** A POTENTIAL HAZARDOUS SITUATION MAY RESULT IN PROPERTY DAMAGE.
- ◆ **NOTE:** PROVIDE INFORMATION OR SUGGESTIONS THAT HELP CORRECTLY PERFORM A TASK.
- ◆ **TORQUE:** WHEN ITALICIZED “TORQUE” ALERTS THE INSTALLER TO TIGHTEN FASTENERS TO A SPECIFIED VALUE.

BOLT TORQUE CHART

BOLT SIZE	GRADE 5 TORQUE	GRADE 8 TORQUE
1/4"-20	<i>8 FT-LB</i>	<i>12 FT-LB</i>
3/8"-16	<i>31 FT-LB</i>	<i>44 FT-LB</i>
3/8"-24	<i>35 FT-LB</i>	<i>49 FT-LB</i>
1/2"-13	<i>75 FT-LB</i>	<i>106 FT-LB</i>
1/2"-20	<i>85 FT-LB</i>	<i>120 FT-LB</i>
9/16"-18	<i>121 FT-LB</i>	<i>171 FT-LB</i>
5/8"-11	<i>150 FT-LB</i>	<i>212 FT-LB</i>
5/8"-18	<i>170 FT-LB</i>	<i>240 FT-LB</i>
3/4"-16	<i>297 FT-LB</i>	<i>420 FT-LB</i>
7/8"-14	<i>474 FT-LB</i>	<i>669 FT-LB</i>

SAFETY

YOUR SAFETY AND THE SAFETY OF OTHERS IS VERY IMPORTANT.

- ◆ READ AND UNDERSTAND ALL SAFETY PRECAUTIONS AND INSTRUCTIONS BEFORE INSTALLING THIS PRODUCT.

CAUTION: TRUCKS EQUIPPED WITH PARKING SENSORS OR OTHER LIKE DEVICES.

- ◆ RELOCATION OF THESE DEVICES WILL ALTER THE FIELD OF VIEW. IT IS THE RESPONSIBILITY OF THE OWNER TO UNDERSTAND HOW THESE CHANGES AFFECT THE OPERATION OF THESE SYSTEMS.

WARNING: COMPONENTS UNDER PRESSURE.

- ◆ BLEED ALL PRESSURE FROM THE AIR SYSTEM BEFORE PERFORMING ANY MAINTENANCE OR SERVICE. SERIOUS INJURY COULD OCCUR IF COMPONENTS ARE REMOVED WHILE SYSTEM IS PRESSURIZED.

WARNING: CARELESS INSTALLATION CAN RESULT IN SERIOUS INJURY OR PROPERTY DAMAGE

- ◆ WEAR EYE PROTECTION.
- ◆ DISCONNECT THE BATTERY BEFORE DOING ANY WORK ON THE VEHICLE.
- ◆ WORK ON FLAT LEVEL GROUND.
- ◆ ENSURE TRUCK IS PROPERLY SUPPORTED BY JACK STANDS. NEVER WORK UNDER A VEHICLE SUPPORTED ONLY BY HYDRAULIC JACKS.
- ◆ TAKE PRECAUTIONS WHEN LIFTING PRODUCT. DUE TO THE SIZE AND WEIGHT OF THIS PRODUCT TWO PEOPLE ARE RECOMMENDED FOR INSTALLATION.
- ◆ NEVER WORK DIRECTLY UNDER THE PRODUCT UNTIL IT HAS BEEN SECURELY FASTENED TO THE VEHICLE.
- ◆ AVOID SHARP, HOT, AND MOVING COMPONENTS WHEN ROUTING ELECTRICAL CABLES AND AIR LINES.
- ◆ IF DRILLING, INSPECT BOTH SIDES OF THE SURFACE AND REMOVE/RELOCATE ANY OBJECTS LOCATED IN THE WAY.
- ◆ ENSURE ALL BOLTS ARE PROPERLY TIGHTENED BEFORE DRIVING.

PRODUCT OWNER RESPONSIBILITIES

- ◆ PRODUCT OWNER IS SOLELY RESPONSIBLE FOR PRE-OPERATION INSPECTION, PERIODIC INSPECTIONS, MAINTENANCE, AND USE OF THE PRODUCT AS SPECIFIED BY KELDERMAN MFG. INC. OF PARTICULAR IMPORTANCE IS THE RE-TORQUE OF FASTENERS.
- ◆ THIS RE-TORQUE MUST BE PERFORMED WITHIN 2500 MILES OF THIS PRODUCT BEING PUT INTO SERVICE.
- ◆ THE KELDERMAN AIR SUSPENSION IS FULLY AUTOMATIC IN CONTROLLING THE HEIGHT OF THE CHASSIS WHEN PROPERLY INSTALLED.
- ◆ NO MANUAL INTERVENTION TO CONTROL AIR PRESSURE OR RIDE HEIGHT IS NEEDED DURING THE COURSE OF NORMAL OPERATION.
- ◆ PRODUCT OWNER IS RESPONSIBLE FOR “*DOWN TIME*” EXPENSES, CARGO DAMAGE, AND ALL BUSINESS COSTS AND LOSSES RESULTING FROM A WARRANTABLE FAILURE.

SERVICE INTERVALS

FIRST 2,500 MILES

- ◆ CHECK RIDE HEIGHT $\pm 1/4$ ”
- ◆ CHECK FOR AIR LEAKS AROUND FITTINGS.
- ◆ CHECK FOR ANY LOOSE OR RUBBING HOSES AND WIRES.
- ◆ RE-TORQUE ALL HARDWARE.

EVERY 30,000 MILES

- ◆ CHECK RIDE HEIGHT $\pm 1/4$ ”
- ◆ CHECK FOR AIR LEAKS AROUND FITTINGS.

DISASSEMBLY

1. BEFORE DOING ANYTHING, MEASURE THE PINION ANGLE AND RECORD IT. THIS IS IMPORTANT BECAUSE YOU WILL NEED TO PUT THE AXLE BACK TO THIS MEASUREMENT AFTER INSTALLATION. SEE FIGURE 1.

PINION ANGLE _____



2. TAKE THE FOLLOWING MEASUREMENTS FOR FUTURE REFERENCE. THESE MEASUREMENTS WILL BE USED TO ADJUST THE SUSPENSION AFTER INSTALLATION.

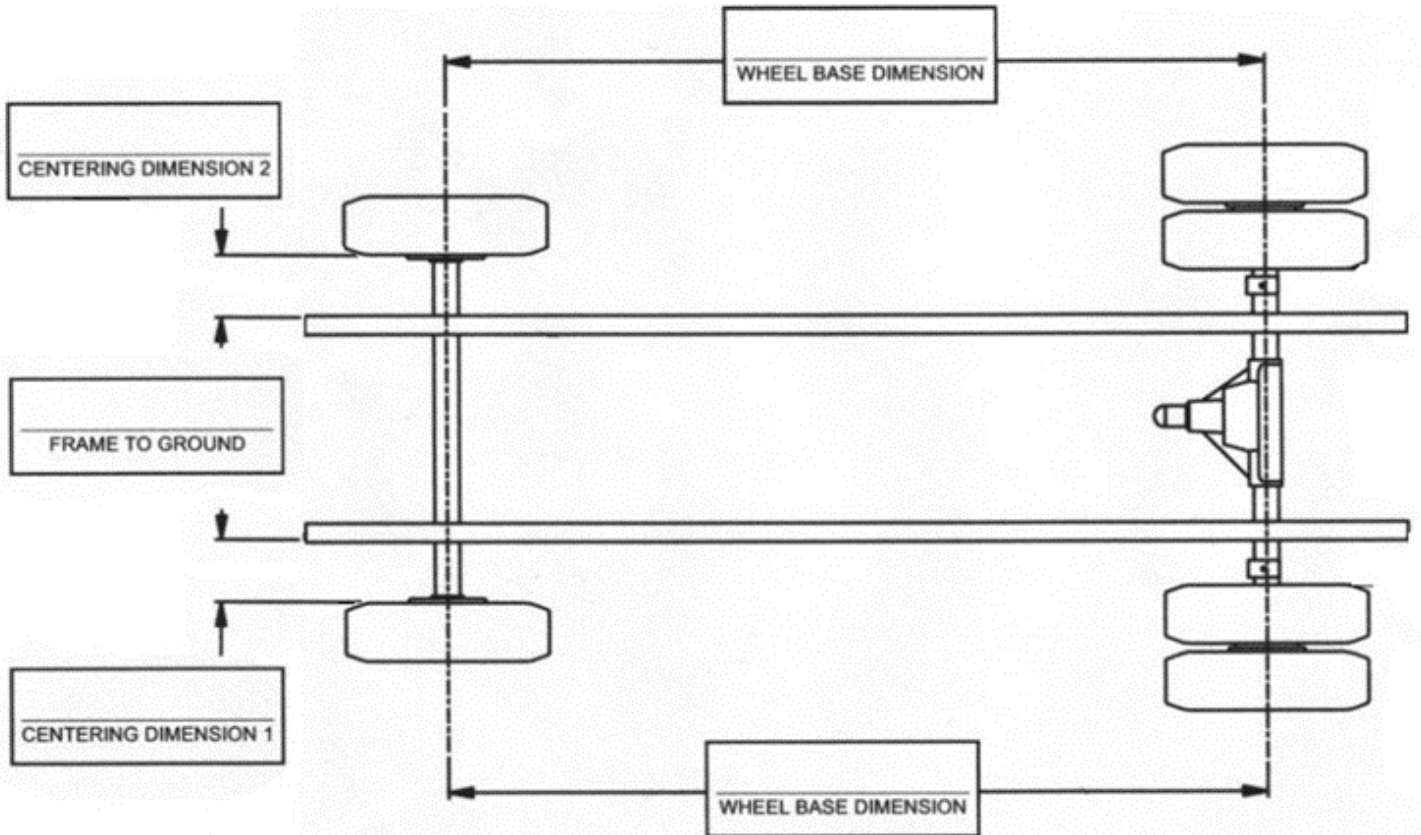

3. CHOCK THE FRONT WHEELS. LIFT THE REAR OF THE VEHICLE JUST ENOUGH TO TAKE THE WEIGHT OFF THE LEAF SPRINGS. PLACE JACK STANDS UNDER THE FRAME AND CHOCK THE REAR TIRES SO THE AXLE WON'T ROLL. SUPPORT THE FRONT OF THE PINION WITH A JACK STAND.

4. IF EQUIPPED, UN-BOLT AND REMOVE THE SHOCK ABSORBERS.

5. UNBOLT THE PARKING BRAKE CABLE BRACKET FROM THE TOP OF THE DIFFERENTIAL HOUSING.

6. REMOVE ANY EXHAUST THAT EXTENDS OVER AND PAST THE REAR AXLE. **NOTE:** ON TRUCKS EQUIPPED WITH THIS STYLE EXHAUST IT WILL NEED TO BE MODIFIED TO EXIT IN FRONT OF THE AXLE.

7. UNBOLT THE LEAF SPRINGS FROM THE AXLE. KEEP THE CAST LOWER AXLE CLAMPS, THEY WILL BE REUSED DURING INSTALL. **NOTE:** THE TIRES DO NOT NEED TO BE REMOVED.

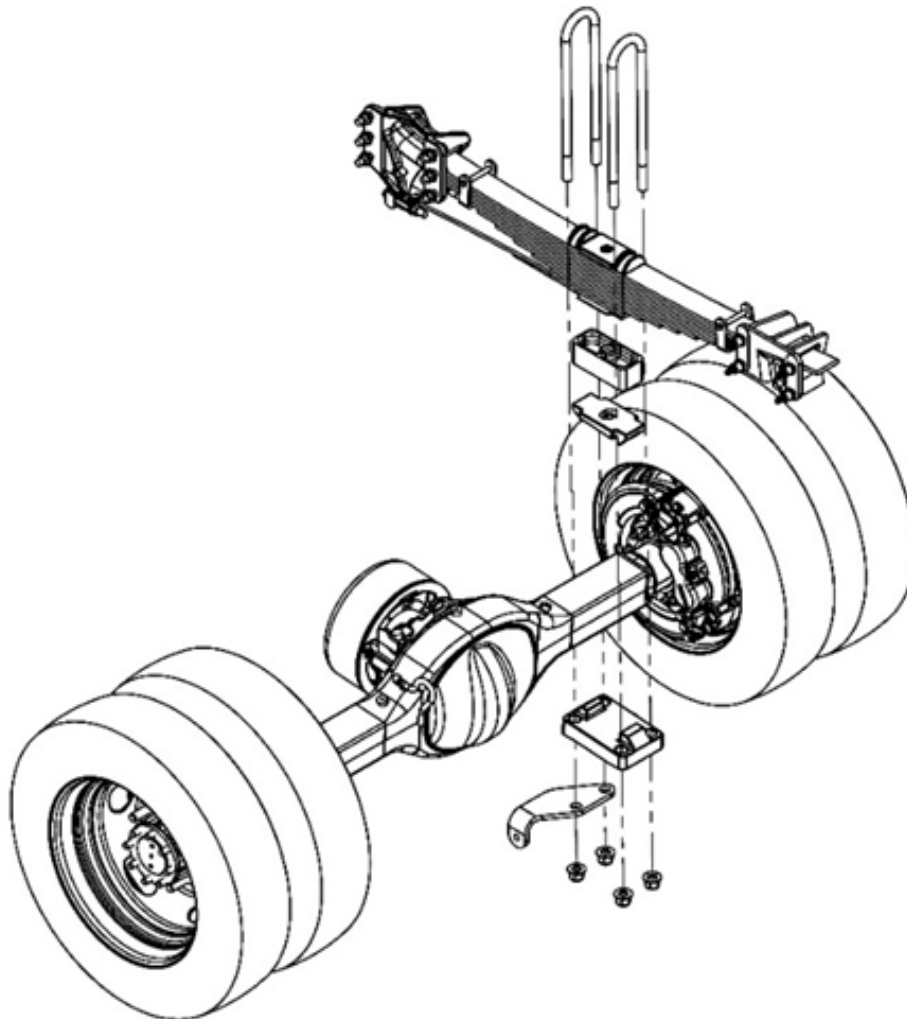

8. REMOVE THE PINS FROM EACH SPRING HANGER AND UN-BOLT THE LEAF SPRING FROM THE FRONT HANGER. THE LEAF SPRING IS NOW FREE TO BE REMOVED.

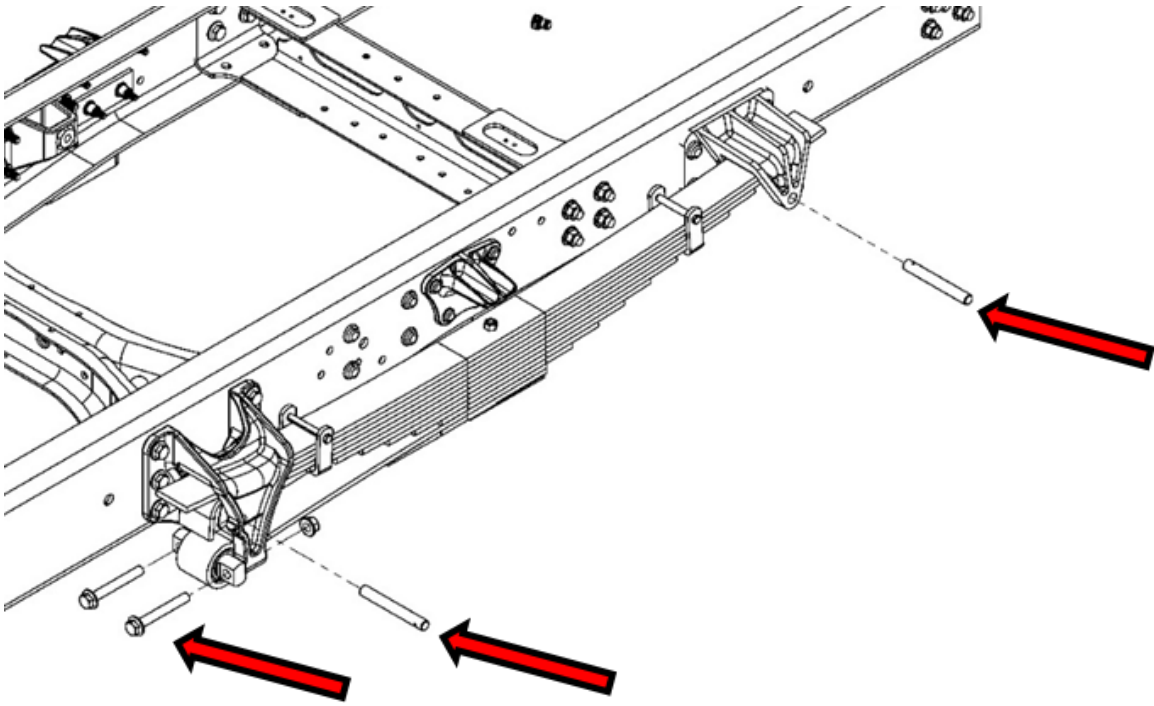

9. MARK, MEASURE, AND NOTE THE FRAME WIDTH AT EACH CROSSMEMBER. USING THOSE SAME MARKS, MEASURE THE FRAME DIAGONALLY TO CHECK FOR SQUARE. THESE MEASUREMENTS WILL BE COMPARED AGAINST WHEN INSTALLING THE SIDE PLATES.

FRAME WIDTH: FORWARD _____ DIAGONAL MEASUREMENT # 1 _____
FRAME WIDTH: MIDDLE _____ DIAGONAL MEASUREMENT # 2 _____
FRAME WIDTH: REAR _____

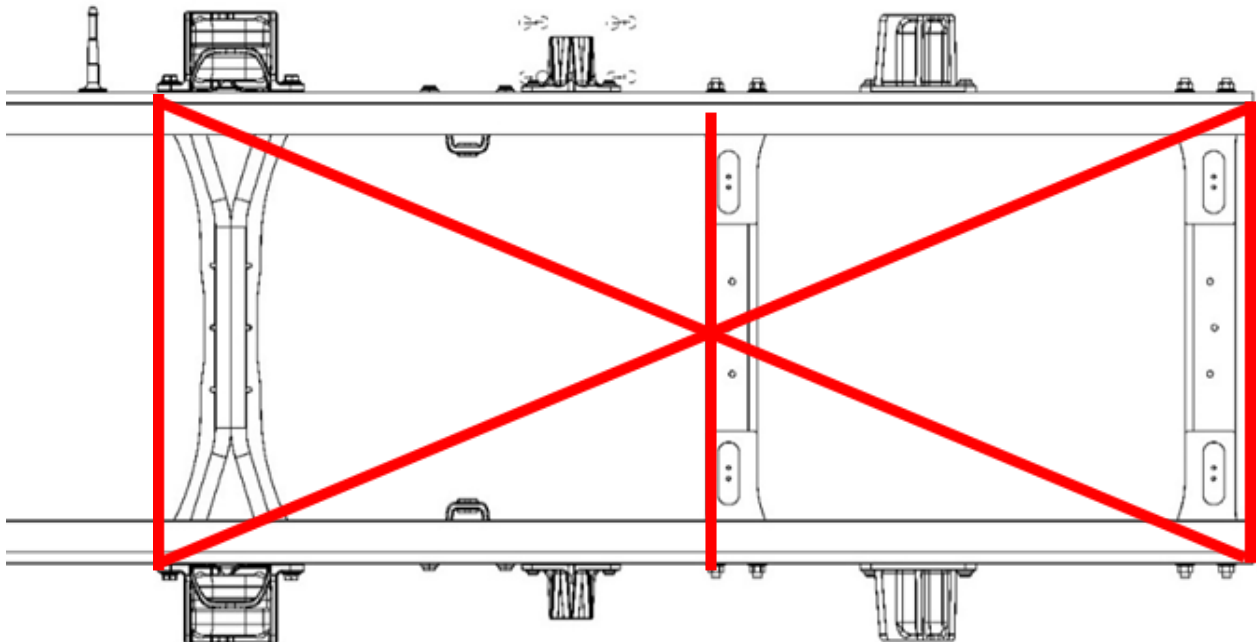

10. MARK THE LOCATION OF THE FORWARD AND MIDDLE CROSSMEMBERS ON THE FRAME RAILS.

11. ON TRUCKS EQUIPPED WITH A MID-MOUNT FUEL TANK REMOVE THE TANK STRAPS AND SLIDE THE TANK AWAY FROM THE FRAME TO GAIN ACCESS TO THE SPRING HANGER HARDWARE. **CAUTION:** TAKE CAUTION NOT TO DAMAGE OR KINK ANY LINES RUNNING TO THE TANK.

12. REMOVE THE SPRING HANGERS, BUMP STOP PADS, AND SHOCK BRACKETS (IF EQUIPPED) FROM ONLY ONE FRAME RAIL. **NOTE: AT THIS POINT IT IS RECOMMENDED TO ONLY REMOVE PARTS FROM ONE FRAME RAIL THEN INSTALL NEW COMPONENTS BEFORE MOVING TO THE OPPOSITE SIDE.**

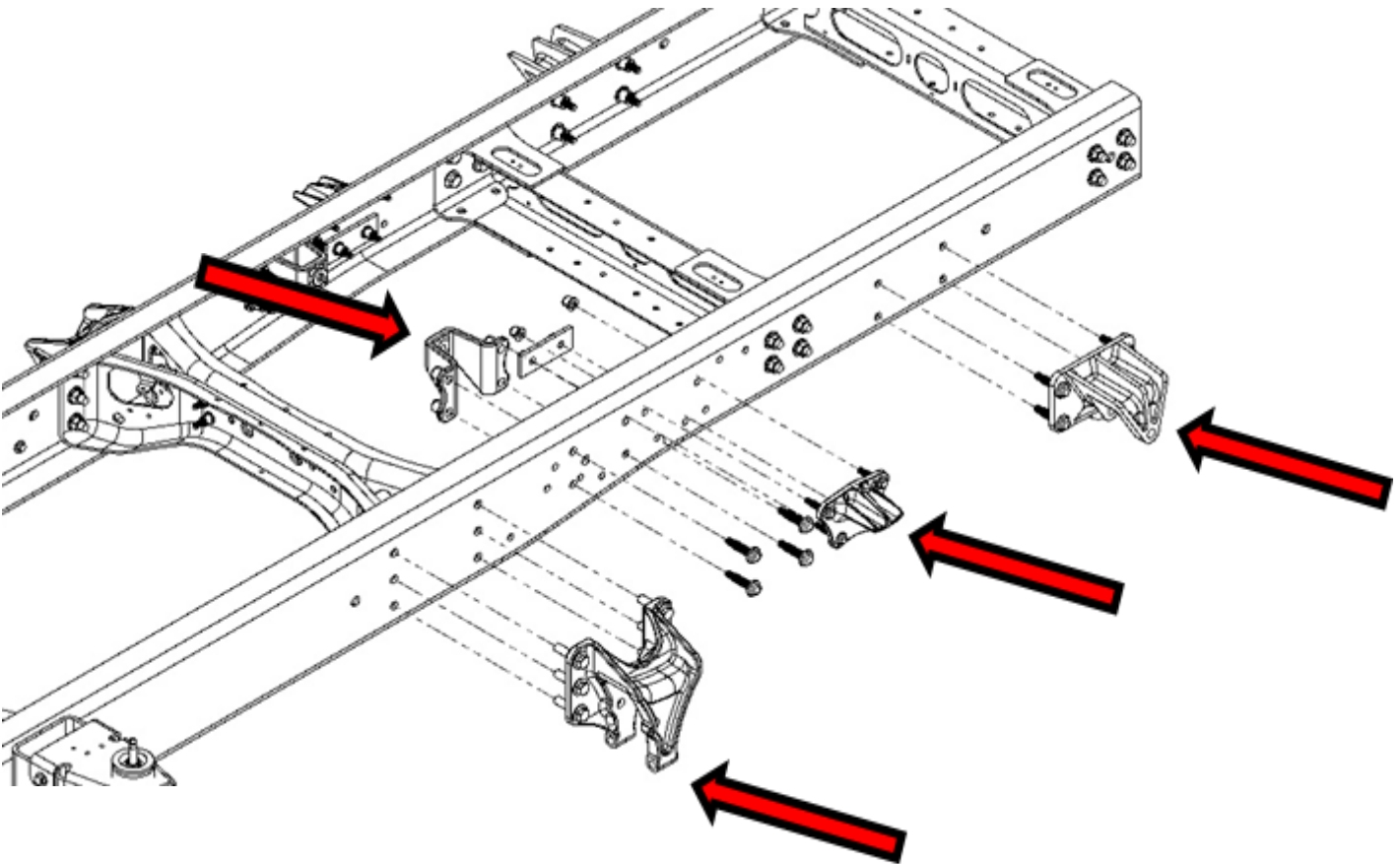

13. REMOVE THE HUCK BOLTS SPLIT THE NUT USING A CUTOFF WHEEL OR AN AIR CHISEL.

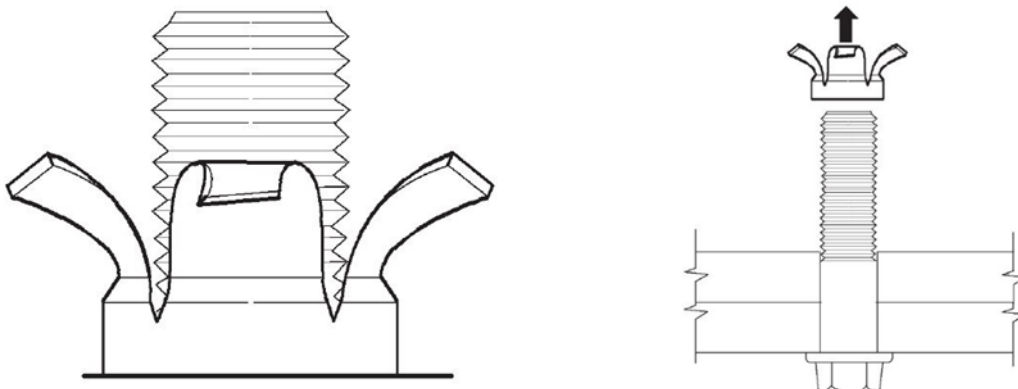

14. BETWEEN THE FORWARD AND MIDDLE CROSSMEMBER UN-BOLT ALL ELECTRICAL, FUEL, BRAKE LINES, AND CABLES FROM EACH FRAME RAIL.

15. UN-BOLT THE MIDDLE CROSSMEMBER. **NOTE:** SUPPORT THE REAR FUEL TANK ON TRUCKS EQUIPPED WITH ONE.

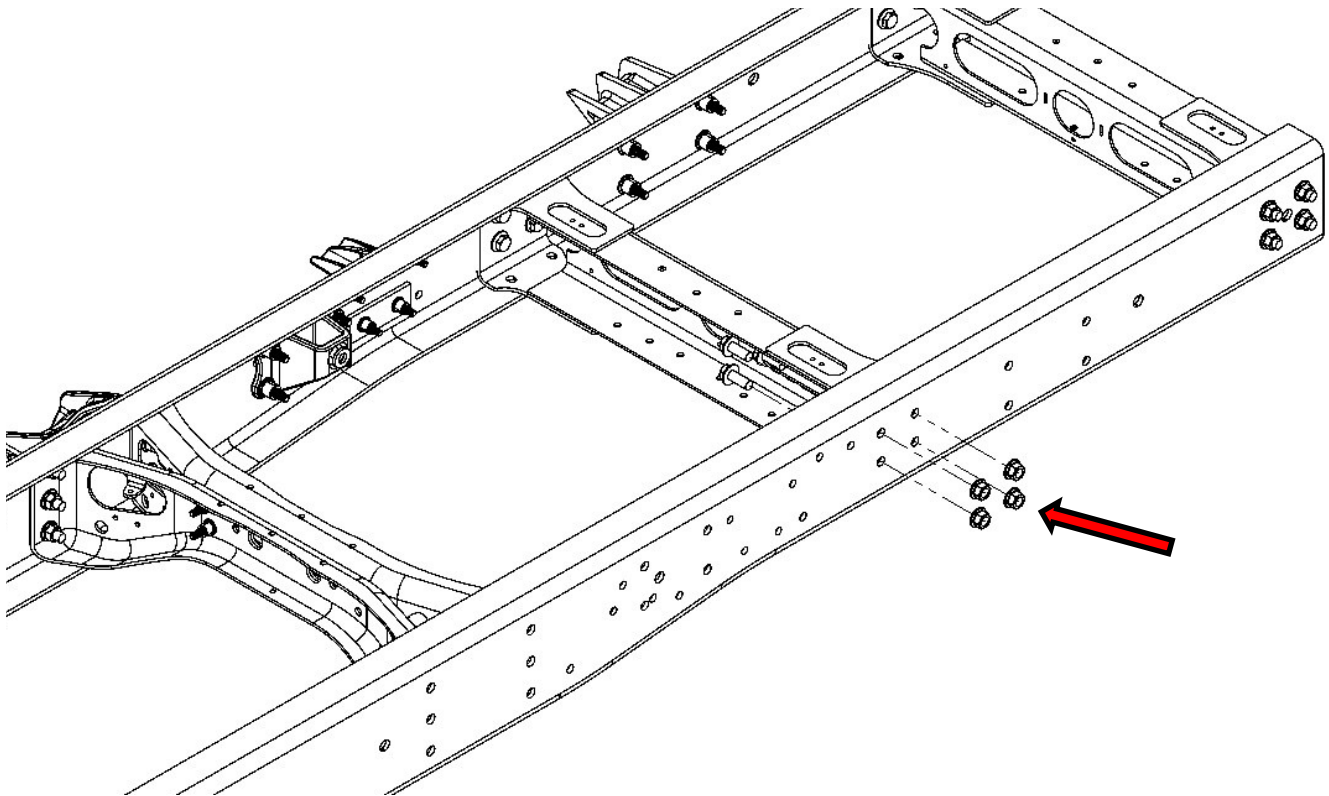

16. PROCEED TO *STEP 1* OF THE *KIT INSTALLATION* SECTION OF THESE INSTRUCTIONS AND INSTALL THE KELDERMAN SIDE PLATE ONTO THE NOW BARE FRAME RAIL.

ASSEMBLY

PASSENGER SIDE SHOWN, A DIRECT MIRROR OF THE DRIVER'S SIDE

1. RE-ALIGN THE FORWARD AND MIDDLE CROSSMEMBERS WITH THE MARKS MADE DURING DISASSEMBLY AND INSTALL SIDE PLATES (#10006393-DS & 10006316-PS) TO FRAME RAIL WITH HARDWARE SHOWN BELOW. DRILL HOLES AS SHOWN.

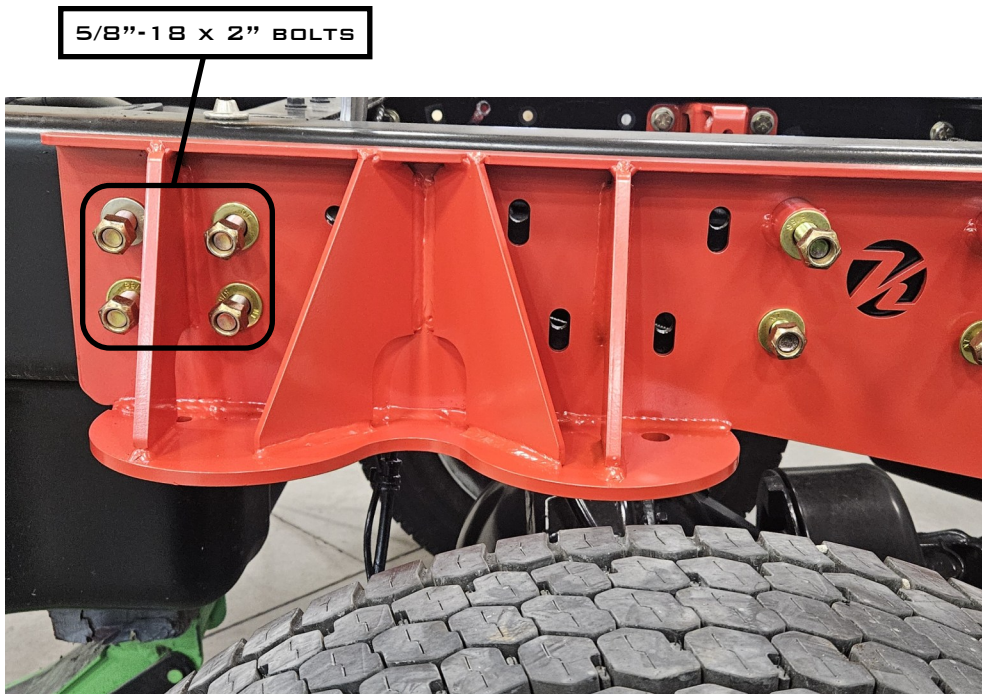
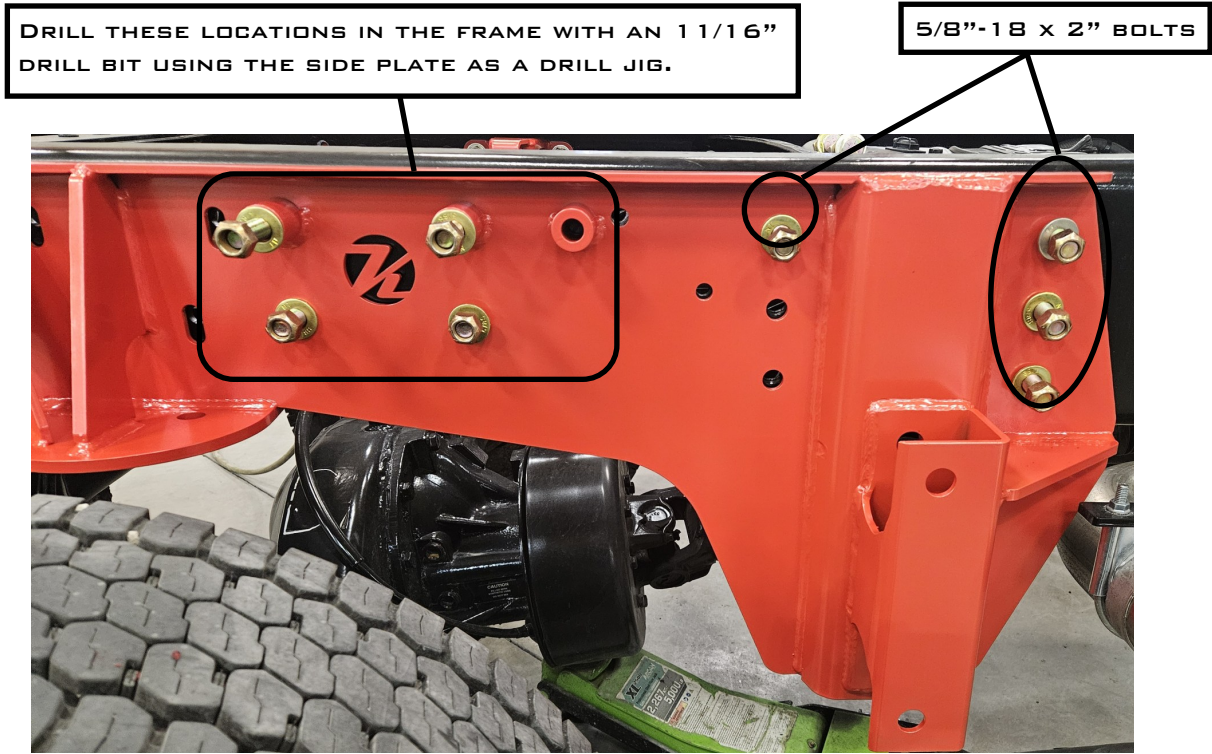

2. INSTALL SENSOR BRACKETS (#10006467) TO THE SENSOR AND THEN INSTALL THE ASSEMBLY TO THE SIDE PLATES WITH 5/8"-18 X 2-1/2" BOLTS.

ATTACH THE SENSOR TO THE SENSOR BRACKET BEFORE INSTALLING TO THE SIDE PLATE.

USE 1/4"-20 X 1-1/4" SOCKET HEAD CAP SCREW, SPLIT LOCK WASHER AND HEX NUT

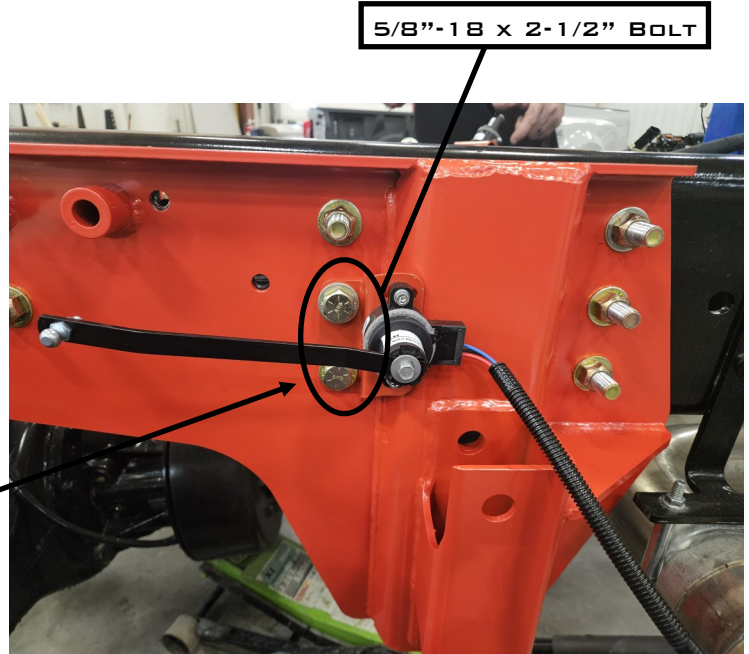

3. INSTALL SHOCK MOUNTS (#10006533) USING THE 5/8"-18 X 4" & 4-1/2" BOLTS IN THE CENTER OF THE SIDE PLATE AROUND THE "K". THE BOLT SHOULD BE ORIENTED WITH THE BOLT HEAD INSIDE THE FRAME

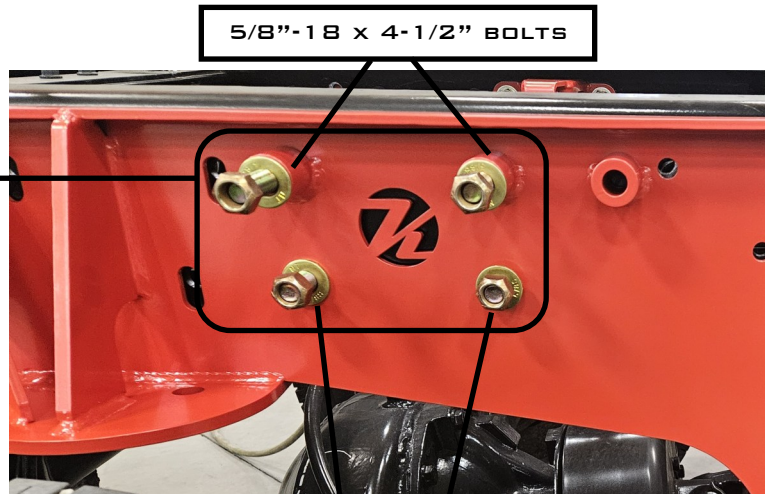
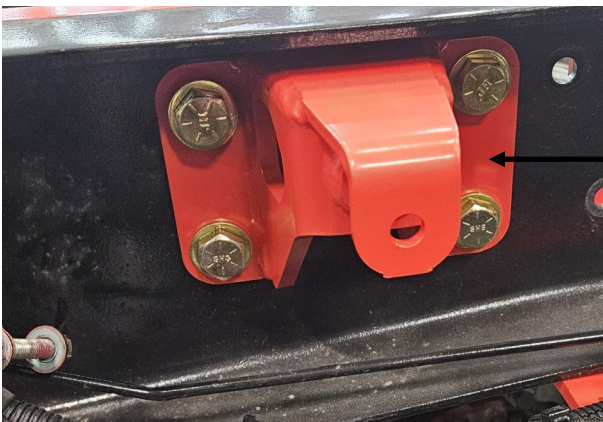

5/8"-18 x 4" BOLTS

NOTE: ON THE DS, IT HELPS TO INSTALL THE TOP TRAILING ARM BAR BEFORE BOLTING ON THE DS SIDE PLATE. THE TOP TRAILING ARM BAR INSTALLS WITH 7/8"-14 X 5-1/2" BOLT.

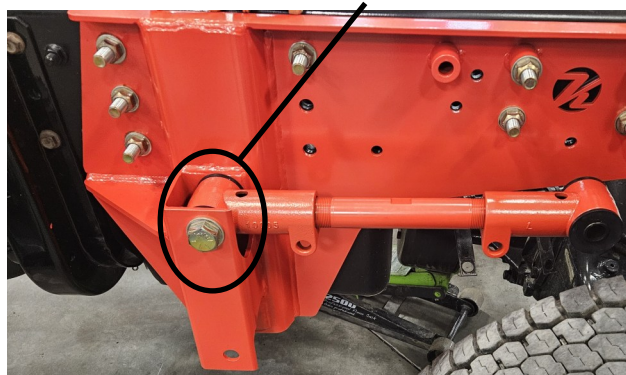

4. INSTALL 1/2"-20 X 1-3/4" BOLTS IN THE PS SIDE PLATE.

1/2"-20 X 1-3/4" BOLTS



5. INSTALL 1/2"-20 X 1-3/4" BOLTS IN THE DS SIDE PLATE.



NOTE: THE STANDOFF BUSHINGS ALLOW FOR ACCESSORY BRACKETS TO BE MOUNTED WITHOUT CUTTING THE SIDE PLATE TOP FLANGE.

ATTACH THE HARNESS STRAP HERE WITH 1/2"-20 X 1-3/4" BOLT.

6. INSTALL END LINK FRAME BRACKET (#10006442) USING 5/8"-18 X 2" BOLTS. THE END LINK FRAME BRACKET WILL BOLT UP AT THE LOCATION OF THE REMOVED REAR SPRING HANGER.



5/8"-18 x 2" BOLTS

7. INSTALL THE UPPER PANHARD BAR BRACKET (#10006381) ONTO THE PASSENGER SIDE FRAME RAIL. USE 1/2"-20 X 2" BOLTS TO FASTEN THRU THE FRAME RAIL. USE HARDWARE TO FASTEN THE BOTTOM FLANGE OF THE PANHARD BAR BRACKET TO THE SIDE PLATE. ON THE PASSENGER SIDE CUT OFF THE FACTORY BRAKE LINE BRACKET AFTER THE FIRST HOLE AND FASTEN IT TO THE FORWARD CARRIAGE BOLT, AND CAUSE DAMAGE.

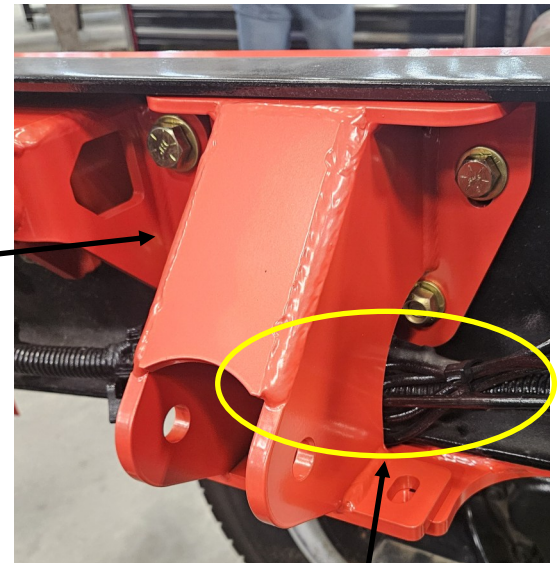

NOTE: ROUTE THE WIRING HARNESS THRU THE OPENING AT THE BOTTOM OF THE PANHARD BAR BRACKET BEFORE FASTENING.

CAUTION: POSITION THE SMOOTH HEAD OF THE 1/2"-13 X 1-3/4" CARRIAGE BOLT DOWN OR IT WILL RUB ON THE BAG

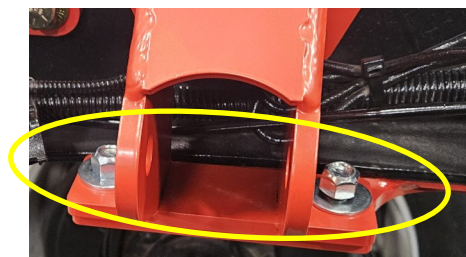

8. DRILL OUT HOLE TO 3/8" AS SHOWN AND ATTACH THE GROUND STRAP AND BOLT.

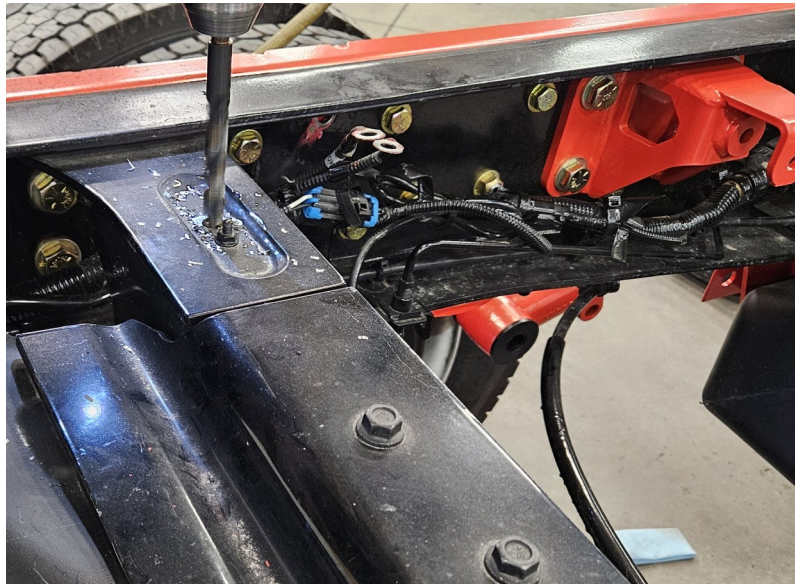

**AN IMPORTANT NOTE BEFORE PERFORMING THE
FOLLOWING PROCEDURE.**

**THE FASTENERS DESCRIBED IN THE FOLLOWING STEPS SHOULD
BE LEFT LOOSE AND THEN TIGHTENED SEQUENTIALLY SO AS TO
GATHER THE COMPONENTS GRADUALLY.**

**FAILURE TO DO THIS WILL RESULT IN MISALIGNMENT OF THE
COMPONENTRY OR BINDING OF THE ASSOCIATED COMPONENTS,
LEADING TO THE LOSS OF CLAMPING FORCE BETWEEN THE
CLAMPS AND THE AXLE OVER TIME.**

**THERE IS ONE EXCEPTION TO THIS : SEE NOTE ON PAGE 19 REGARDING THE SUB
BAG PLATES FOR THE FORWARD AIR BAGS, BOTH DRIVER AND PASSENGER SIDE.**

THIS KIT ADAPTS BOTH CURRENT AXLE SIZE OFFERINGS FROM GENERAL MOTORS. TO DETERMINE YOUR AXLE SIZE, TAKE MEASUREMENTS ACROSS THE TOP AND FRONT OF THE RECTANGULAR AXLE FACES.

AXLE OPTION CODE GL4 MEASURES 4-1/4" WIDE X 4-3/8" TALL.

AXLE OPTION CODE J27 (W/G80 DIFFERENTIAL)

MEASURES 4-7/8" WIDE X 5-1/2" TALL.

IDENTIFY YOUR AXLE TO DETERMINE THE NEED FOR THE ADAPTER KIT.

UPPER AXLE ADAPTERS:

THE UPPER AXLE ADAPTERS ARE BOLT-IN SHIMS, SECURED WITH A 1/4-20 X 3/4" HEX HEAD CAP SCREW AND WASHER. TWO OF THESE SHIMS ARE USED WITH EACH LOWER BAG PLATE WELDMENT. IT IS RECOMMENDED TO ASSEMBLE THESE TO THE LOWER BAG PLATE WELDMENT PRIOR TO FITMENT ON THE AXLE.

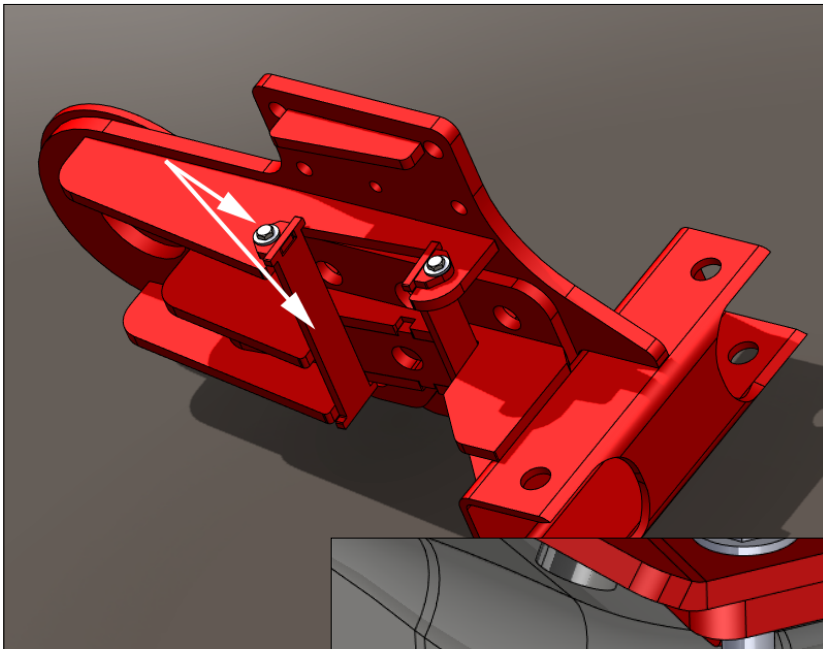

DRIVER'S SIDE LOWER BAG PLATE WELDMENT SHOWN.

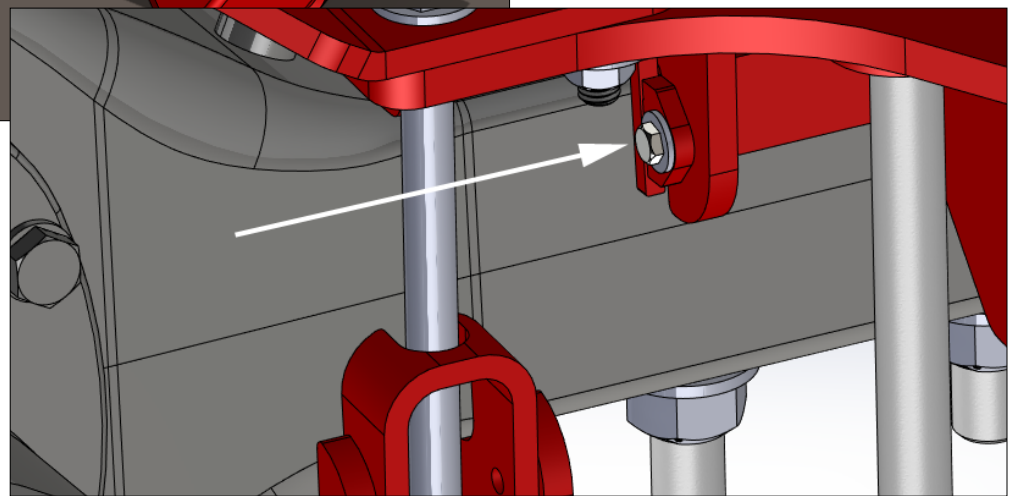

THE PASSENGER SIDE IS A DIRECT MIRROR OF THE DRIVER'S SIDE EXAMPLE.

9. INSTALL THE FRONT AIR BAG (#8997) ONTO THE BAG SUB-PLATE FOR BOTH THE FRONT DRIVER'S SIDE AIR BAG AND THE FRONT PASSENGER SIDE AIR BAGS. TORQUE THIS NUT TO NO MORE THAN 30 LBFT.

SPECIAL ATTENTION MUST BE MADE TO ENSURE THE BAGS ARE PROPERLY ORIENTED AND ALIGNED WITH THESE SUB PLATES. ALIGN AS SHOWN IN THE FOLLOWING DIAGRAMS.

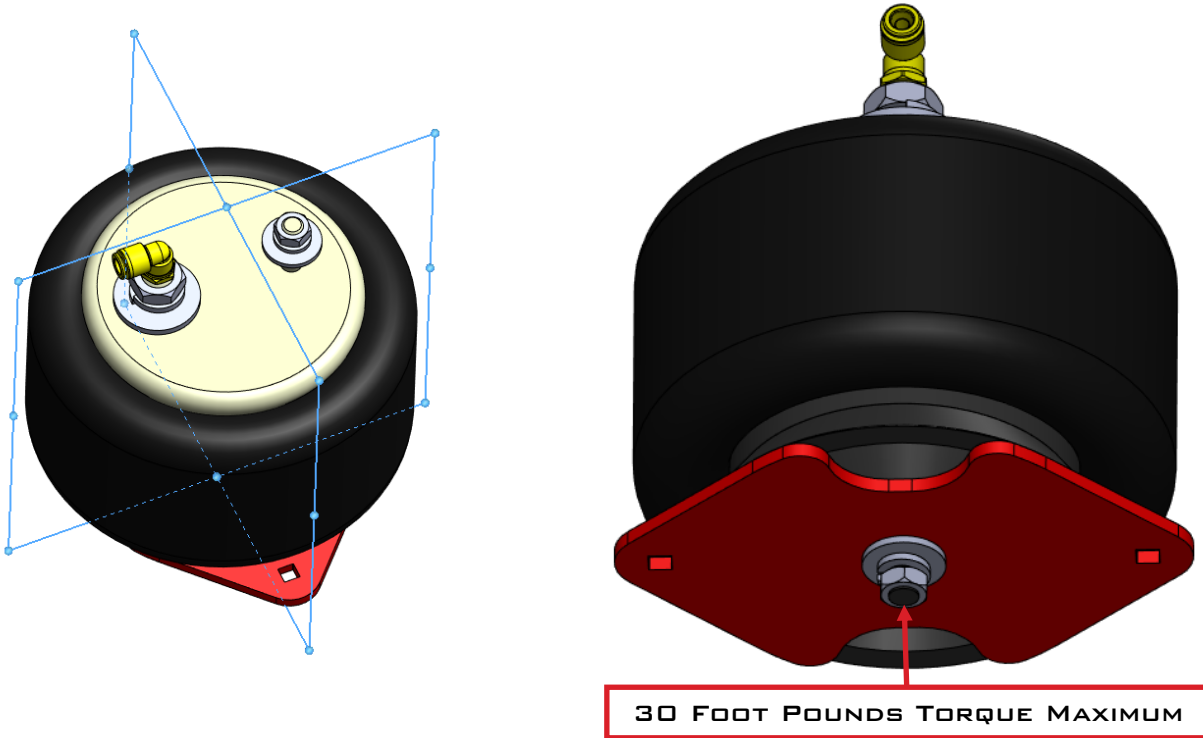

AS NOTED ON PAGE 17: IN THIS INSTANCE YOU WILL NEED TO TIGHTEN THE BAG MOUNTING NUT ON BOTH OF THESE SUBASSEMBLIES PRIOR TO INSTALLATION ON THE LOWER BAG PLATES.

IT IS VERY DIFFICULT TO ACCESS THIS FASTENER FOR PROPER TIGHTENING AFTER THIS STEP.

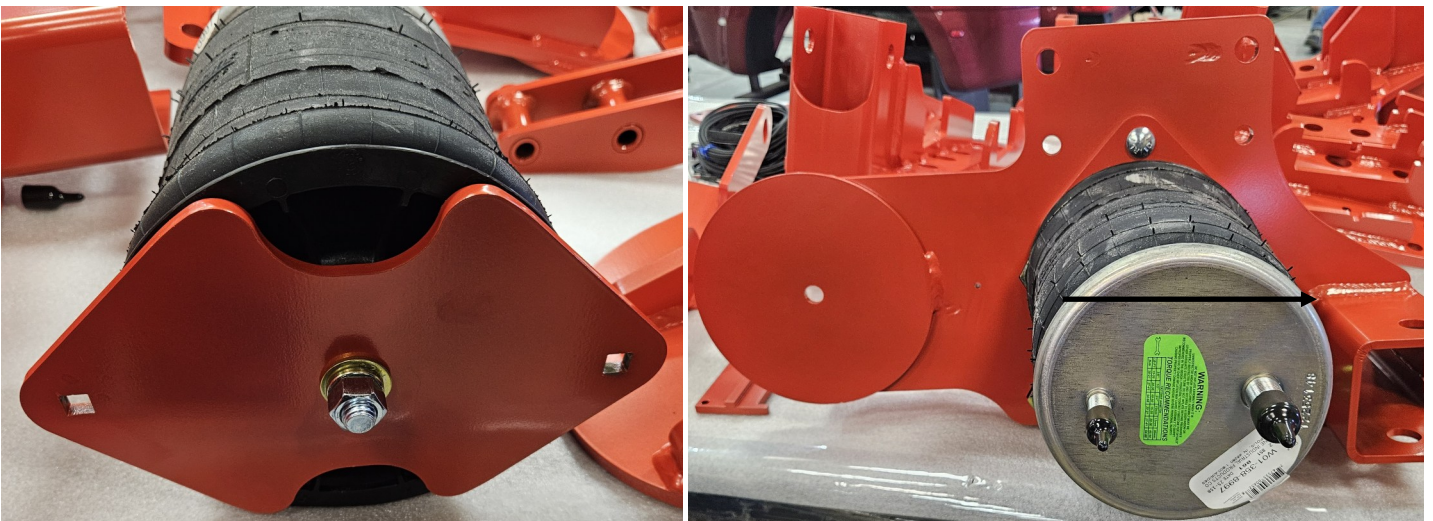

ASSEMBLE THESE SUB ASSEMBLIES TO THE LOWER BAG MOUNT(S) (#10006329-DS & 10006410-PS).

PRIOR TO INSTALLING THE LOWER BAG PLATES, BE SURE TO RE-ORIENT THE BRAKE LINES AS SHOWN ON THE UPPER RIGHT IMAGE. A SLOW DISENGAGEMENT OF THE LINE WILL PREVENT BLEED OFF PRIOR TO REPOSITIONING.

RETIGHTEN THE LINES AS SHOWN.

THEN, USE 7/8"-14 X 9" BOLTS TO BOLT THRU THE LOWER BAG PLATES, THE CAST AXLE CLAMPS, AND LOWER SHOCK EAR PLATES (#10006798-DS & 10006803-PS). DO NOT TIGHTEN HARDWARE YET.

NOTE: FOLLOW THE DIRECTIONAL MARKINGS ON THE CAST AXLE CLAMPS. LEAVE HARDWARE LOOSE.

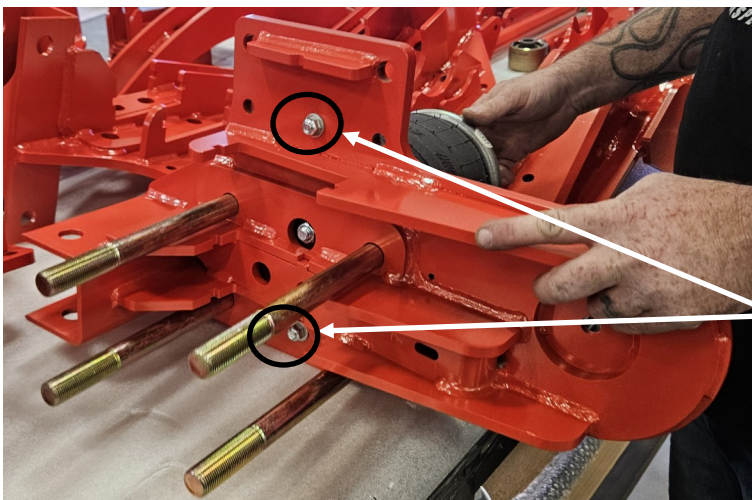

ATTACH AIR BAG ASSEMBLY TO LOWER BAG WELDMENT WITH 3/8"-16 X 1-1/4" CARRIAGE BOLTS.

NOTE: IF YOU HAVE THE LARGE AXLE VERSION, YOU WILL USE 7/8"-14 X 10" BOLTS INSTEAD OF THE 9" LONG ONES.

LOWER AXLE CLAMP ADAPTERS:

THE LOWER CLAMP ADAPTERS HAVE UNIQUE GEOMETRY WHICH FOLLOWS THE SAME GEOMETRY OF THE CLAMPS THEMSELVES. HOWEVER, TO ASSIST IN IDENTIFYING WHICH SIDE IS WHICH, WE HAVE PROVIDED ALIGNMENT HOLES (WHITE ARROWS) WHICH COINCIDE WITH EACH OTHER WHEN THE CLAMPS ARE IN THE CORRECT POSITION. THE HOLES ALIGN ON THE OUTSIDE FLANGE OF THE LOWER AXLE CLAMP AS SHOWN IN THESE IMAGES: **DRIVER'S SIDE SHOWN.**

THE PASSENGER SIDE IS A DIRECT MIRROR OF THE DRIVER SIDE EXAMPLE.

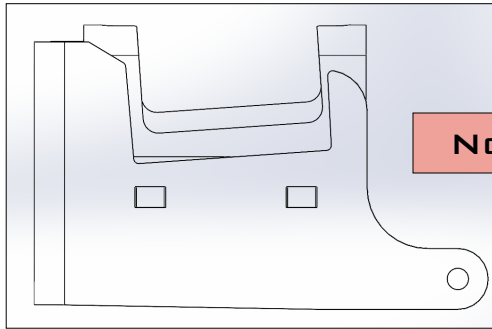

NOTE SIMILAR GEOMETRY

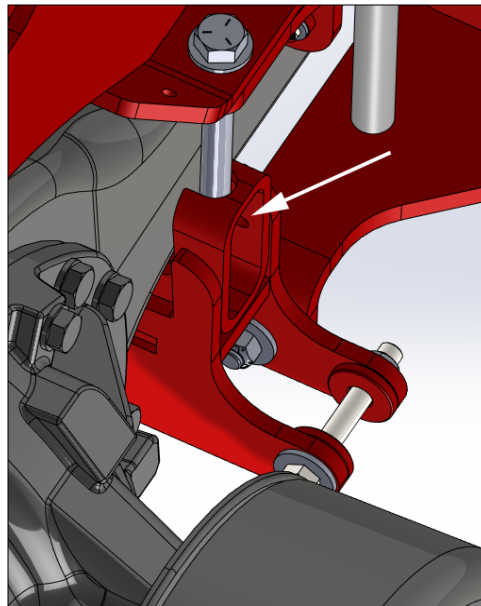
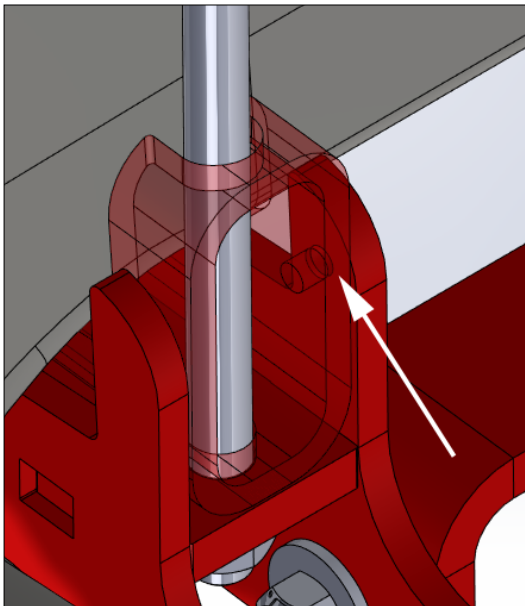

THE APPLICATION OF THIS LOWER CLAMP ADAPTER **ONLY APPLIES TO AXLE OPTION GL4 AND J27 (WITHOUT G80 DIFFERENTIAL).** REFER TO YOUR MEASUREMENTS OF THE AXLE.



10. INSTALL THE PANHARD BAR CROSSMEMBER (#10006384) TO THE LOWER BAG PLATES USING 1/2"-13 X 1-3/4" CARRIAGE BOLTS AND 5/8"-18 X 9" BOLTS TO FASTEN LOWER AXLE CLAMPS (#10006427-DS & 10006431-PS) TO THE AXLE. ALIGN THE HOLES ON THE LOWER SHOCK EAR PLATES WITH THE OTHER COMPONENTS, YOU WILL NEED TO INSTALL THE LOWER TRAILING ARM TO BOLT THE SHOCK EAR TO THE LOWER BAG MOUNT. USE 7/8"-14 X 5-1/2" BOLTS. DO NOT TIGHTEN HARDWARE YET.



1/2"-20 X 1-3/4"



TRAILING ARM NEEDS TO BE INSTALLED TO ATTACH THE SHOCK EAR. THREAD THE LEFT HAND KNUCKLE (10006) ONTO THE TRAILING ARM BAR. USE THE 7/8"-14 X 5-1/2" BOLTS ON THE PS & DS.

11. ASSEMBLE THE REMAINING TRAILING ARM BARS (#52114.5). THREAD CAST KNUCKLES (#10005 & 10006) ONTO THE TRAILING ARM BAR. ADJUST THE KNUCKLES EQUALLY UNTIL THE GAP BETWEEN THE KNUCKLES EQUALS 8-1/8" ON BOTH BARS. INSERT 5/8"-18 X 3" PINCH BOLT INTO THE CAST KNUCKLES BUT DO NOT TIGHTEN.

#10005



#10006

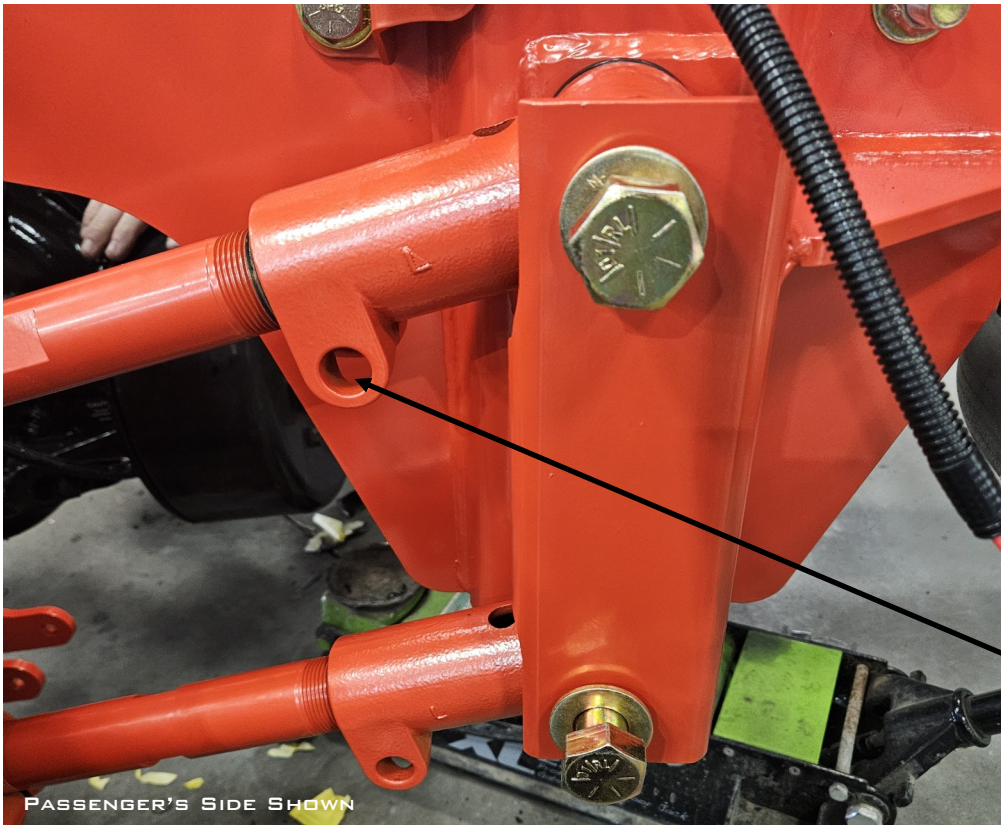

INSTALL AND TIGHTEN PINCH BOLTS AFTER CONFIRMING BARS ARE SET.

****ONCE ALIGNED, TIGHTEN DOWN ALL HARDWARE INSTALLED UP TO THIS POINT****

12. LOCATE PANHARD BAR (#10011537), 7/8" JAM NUTS (#13210-RHT & 13211-LHT) AND JOHNNY JOINTS (#80281-RHT & 80282-LHT). THREAD JAM NUTS ONTO JOHNNY JOINT BEFORE THREADING INTO PANHARD BAR. **NOTE:** SET THE LENGTH OF THE ASSEMBLED BAR TO 18-1/8" MEASURED CENTER TO CENTER. THIS LENGTH MAY NEED TO BE ADJUSTED IN THE NEXT STEP.

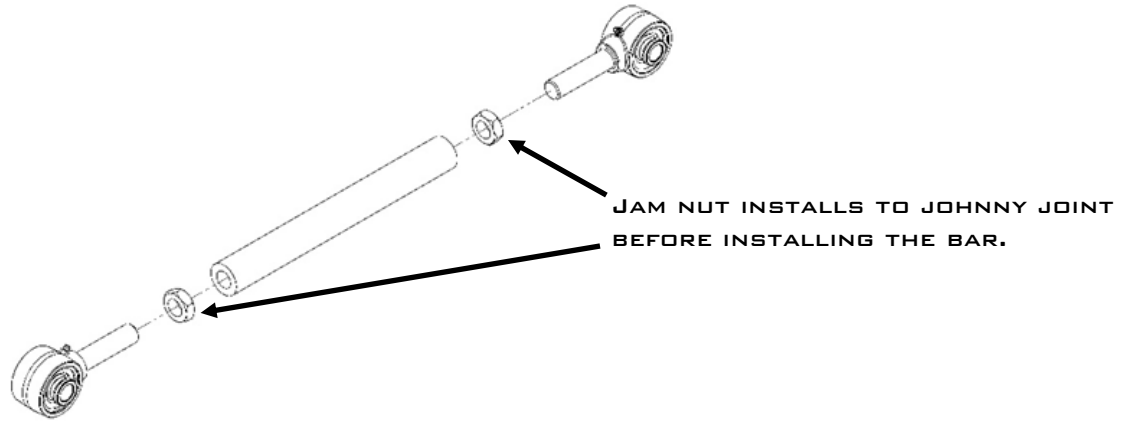

13. INSTALL THE 3/4"-16 x 4-1/2" BOLTS TO THE ASSEMBLED PANHARD BAR INTO THE UPPER PANHARD BAR BRACKET AND PANHARD BAR CROSSMEMBER. **NOTE:** ADJUST ALL FOUR TRAILING ARMS EQUALLY TO MOVE AXLE FORWARD AND BACKWARD. ADJUST THE PANHARD BAR LENGTH TO CENTER THE AXLE UNDER THE FRAME. **TORQUE:** 3/4"-16 PANHARD BAR BOLTS SHOULD BE TORQUED TO 150FT-LB.

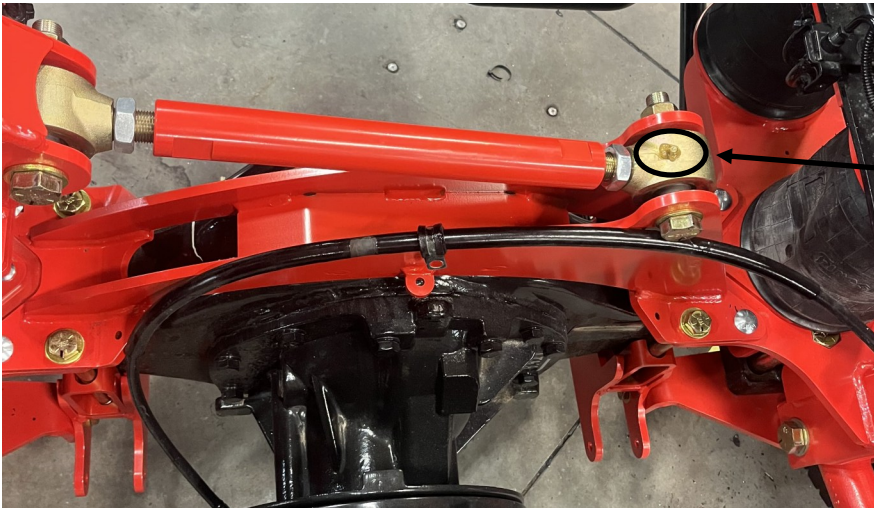

GREASE ZERK ON DRIVERS SIDE WILL FACE UP AND PASSENGER SIDE WILL FACE DOWN.

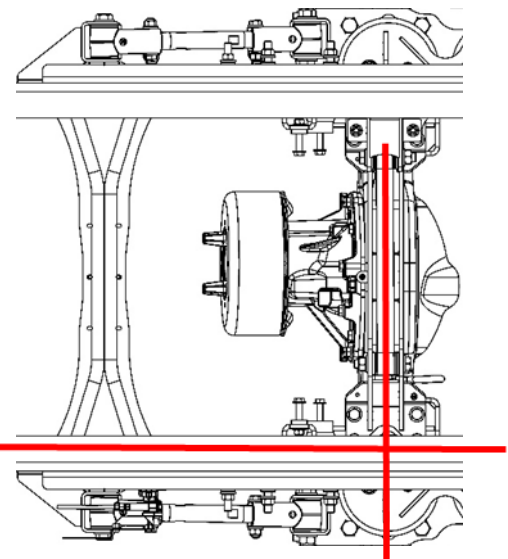

AT RIDE HEIGHT THE PANHARD BAR SHOULD RUN PERPENDICULAR TO THE FRAME RAILS.

14. GREASE SWAY BAR BUSHINGS AND INSTALL ONTO SWAY BAR (#80270). INSTALL THE D-RINGS OVER THE BUSHINGS AND FASTEN TO THE LOWER AXLE CLAMPS USING 3/8" HARDWARE. **NOTE:** INSTALL SWAY BAR WITH THE ARMS ANGLED UP AND THE CENTER ANGLED DOWN.

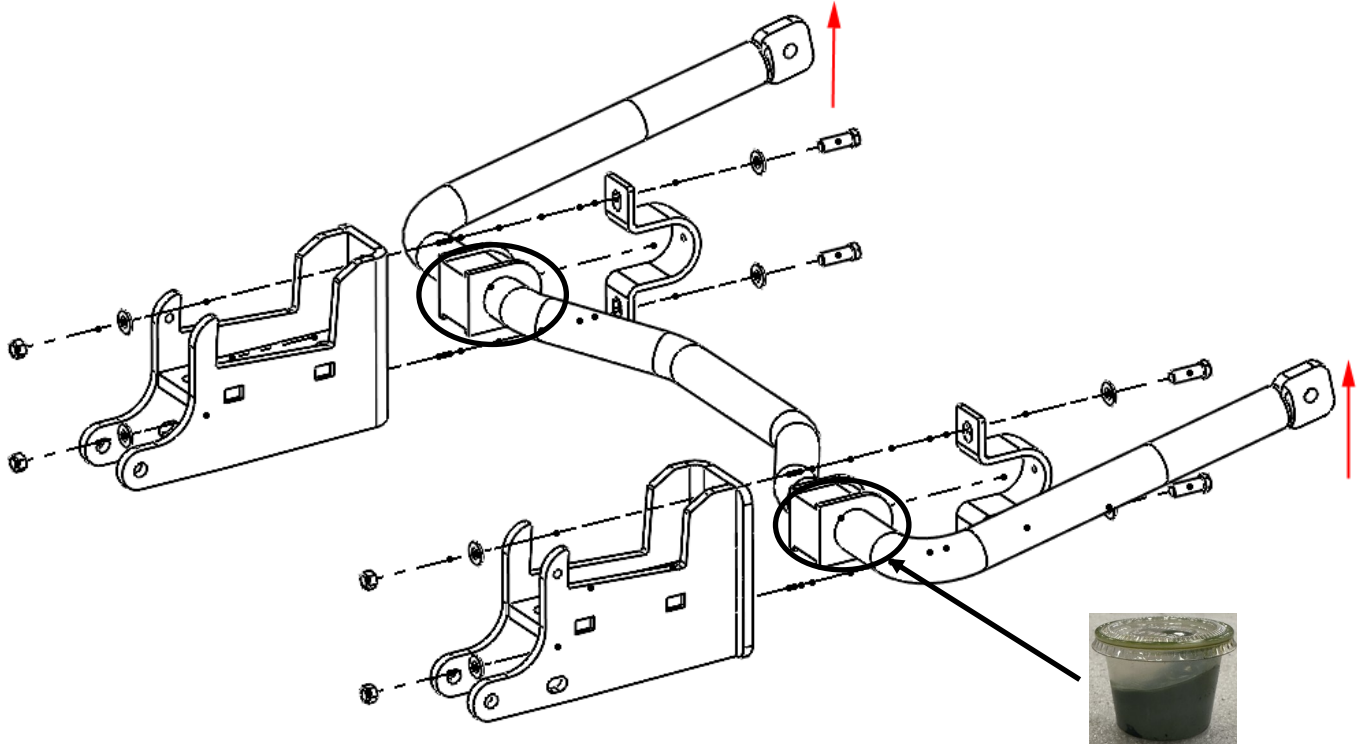

GREASE BUSHINGS
PRIOR TO INSTALL

3/8"-24 x 1-1/4"

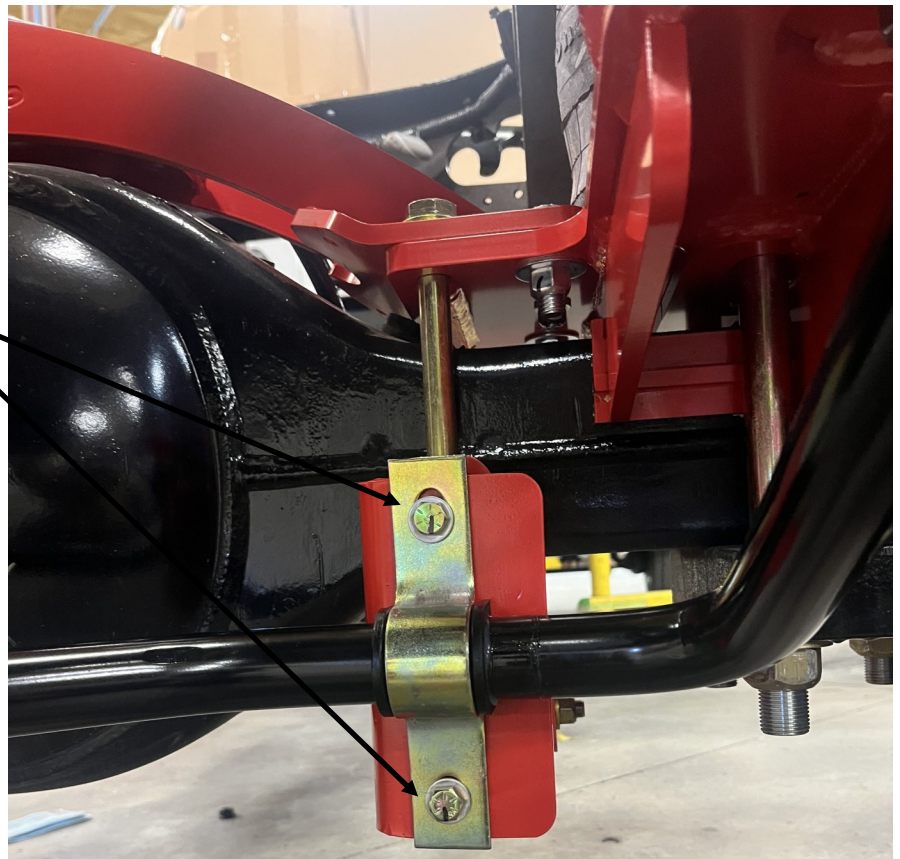

15. INSTALL THE END LINK ASSEMBLY (#10006436) TO THE END LINK MOUNTS USING 1/2"-20 X 3" BOLTS.



NOTE: INSTALL THE END LINK WASHER ON THE SIDE OPPOSITE THE SWAY BAR.



1/2"-20 X 3" BOLTS

16. LOCATE SHOCKS (#10007132/RAP-10136), PIGGYBACK CLAMPS (#80253), WASHER (#11551), 1/2"-20 x 3-1/2" & 3-3/4" BOLTS AND 1/4"-20 x 1-1/4" SOCKET HEAD CAP SCREW. ATTACH CLAMP TO SHOCK BODY AND THEN SLIDE OVER RESERVOIR AND BOLT WITH 1/4"-20 x 1-1/4" SCREW. ATTACH SHOCK TO UPPER SHOCK MOUNT AND LOWER SHOCK EAR WITH 1/2"-20 x 3" BOLTS.

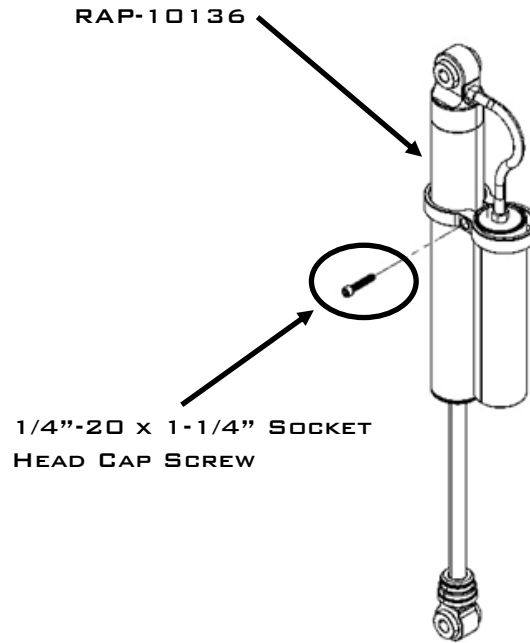
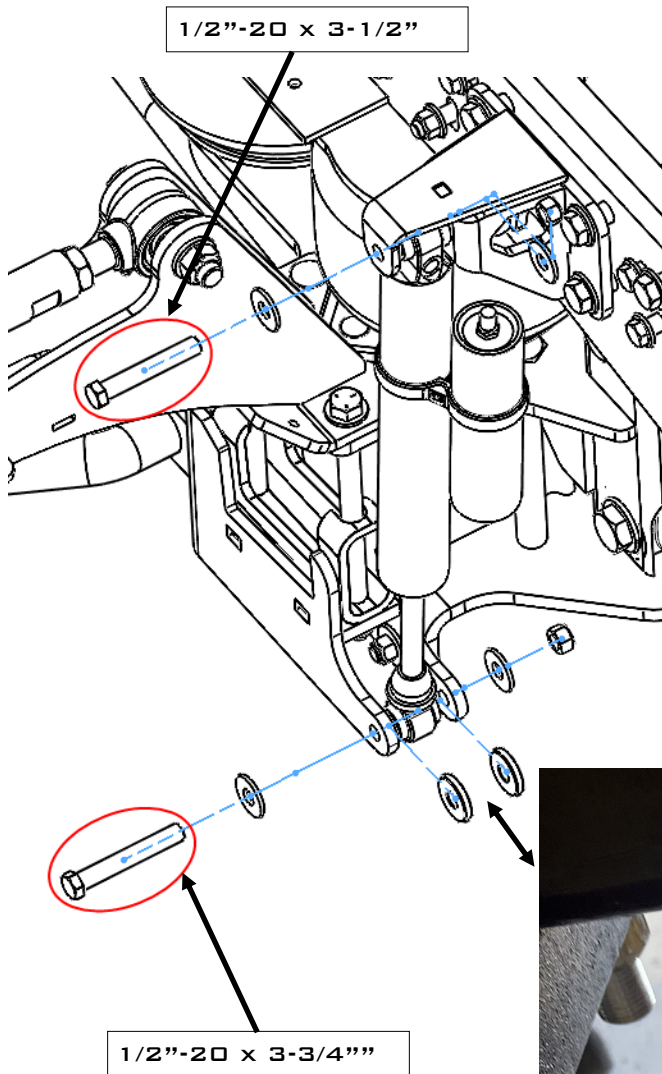

WASHER (#11551) NEED TO BE ON EACH SIDE OF THE SHOCK WHEN BOLTING TO THE LOWER SHOCK EAR.

NOTE: ORIENT THE RESERVOIR TOWARD THE FRONT OF THE TRUCK. CHECK THAT THE RESERVOIR WILL NOT CONTACT ANY BRACKETS OR SNAG ANY HOSES OR LINES AS THE SUSPENSION TRAVELS THRU ITS FULL SWEEP.

17. FASTEN THE PARKING BRAKE CABLE BRACKET REMOVED IN DISASSEMBLY *STEP 5* TO THE TAB ON THE PANHARD BAR CROSSMEMBER. DEPENDING ON THE BRAKE LINE CONFIGURATION, THE BRAKE LINES WILL GO IN BETWEEN BAGS ON LOWER BAG PLATE OR BE ATTACHED TO THE UPPER BAG PLATE AS SHOWN.



IN ORDER TO GET THE BRAKE LINE INTO THE ORIENTATION SHOWN HERE, LOOSENING AND REPOSITIONING MAY BE REQUIRED.



18. THIS KIT IS SUPPLIED WITH TWO BRACKETS THAT WILL MOUNT THE COMPRESSOR BOX TO THE DRIVER'S SIDE FRAME RAIL IN FRONT OF THE MID MOUNT FUEL TANK. THERE IS ALSO A BRACKET THAT WILL LIFT THE AIR DRYER IF THIS MOUNTING METHOD IS USED.

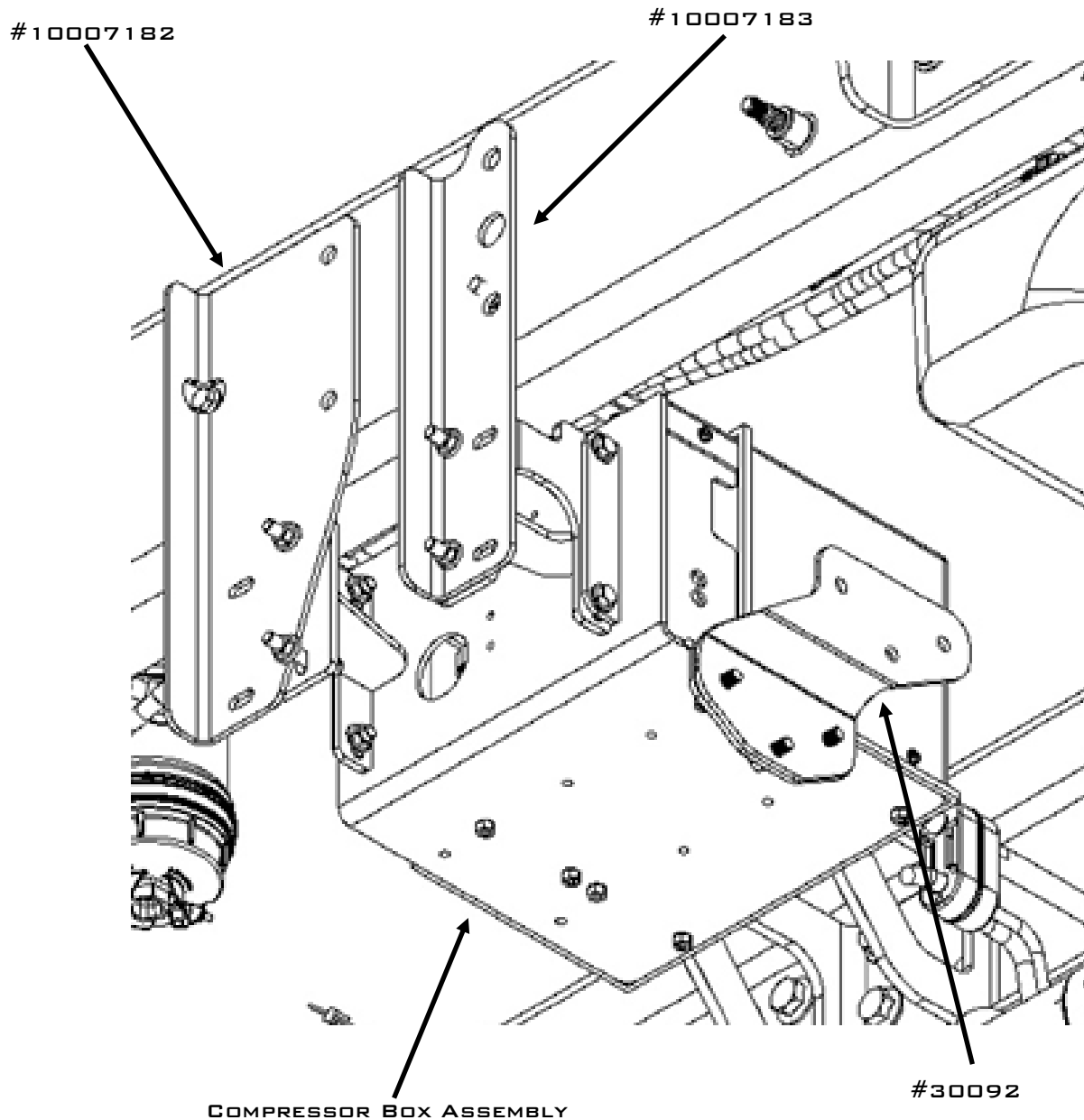

NOTE: REFER TO THE AIR CONTROLS INSTRUCTION MANUAL FOR DIRECTIONS ON PLUMBING AND INSTALLING THE COMPRESSOR.

NOTE: ALTERNATELY THE COMPRESSOR BOX CAN BE MOUNTED AT INSTALLER'S DISCRETION WHEREVER THERE IS ROOM.

19. INFLATE THE AIRBAGS TO 6-1/2" THIS IS THE DESIGNED RIDE HEIGHT FOR THIS KIT.

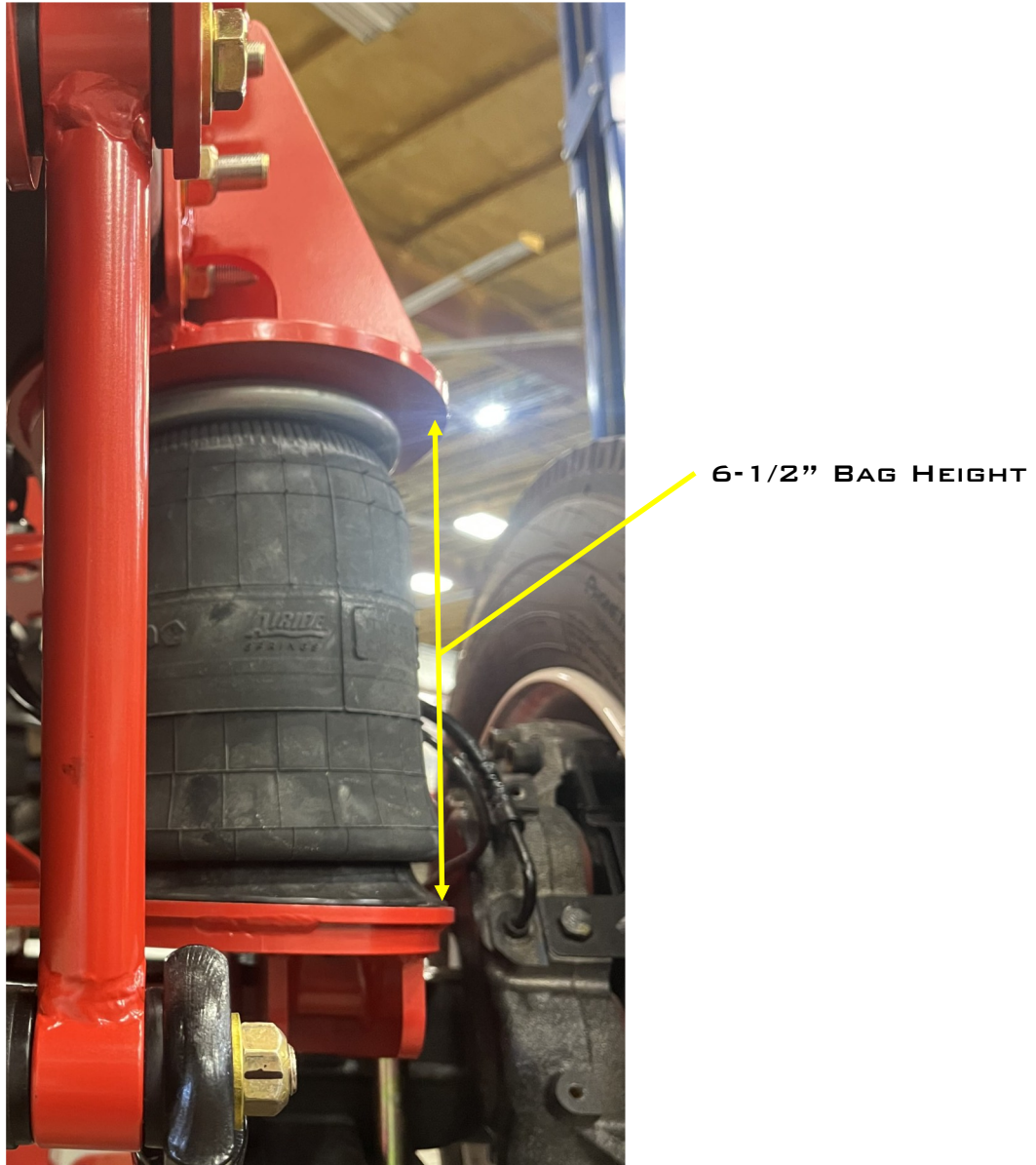

20. WITH THE TRUCK SITTING AT RIDE HEIGHT CHECK PINION ANGLE AND WHEELBASE MEASUREMENTS. ADJUST THE TRAILING ARM BARS AS NEEDED TO SET THE REAR AXLE BACK TO FACTORY POSITION.

21. RE-INSTALL THE EXHAUST.

22. TORQUE ALL FASTENERS TO THE SPECIFICATIONS IN THE CHART BELOW, UNLESS NOTED OTHERWISE IN THESE INSTRUCTION. **SEE PAGE 4 FOR TORQUE CHART.**

23. SWEEP THE SUSPENSION THRU THE FULL RANGE OF MOTION AND CHECK THAT NO COMPONENTS ARE BINDING, COLLIDING, OR RUBBING.

24. GREASE THE PANHARD BAR JOHNNY JOINTS.

25. THE TRUCK IS NOW READY TO TEST DRIVE. IF THE TRUCK PULLS TO ONE DIRECTION, SHORTEN THE OPPOSITE SIDE TRAILING ARMS ONE TURN AND TEST DRIVE AGAIN. REPEAT UNTIL PULL IS ELIMINATED. ALWAYS CHECK THE PINION ANGLE AND BAG HEIGHTS AFTER MAKING ANY TRAILING ARM ADJUSTMENTS.

26. AFTER TEST DRIVING CHECK ALL FASTENERS TO MAKE SURE NOTHING HAS WORKED LOOSE. INSPECT SUSPENSION FOR SIGNS THAT ANY COMPONENT MAYBE BINDING, COLLIDING, OR RUBBING, REPOSITION IF REQUIRED.

27. USE SOAPY WATER TO CHECK AIR COMPONENTS AND LINES FOR ANY LEAKS.

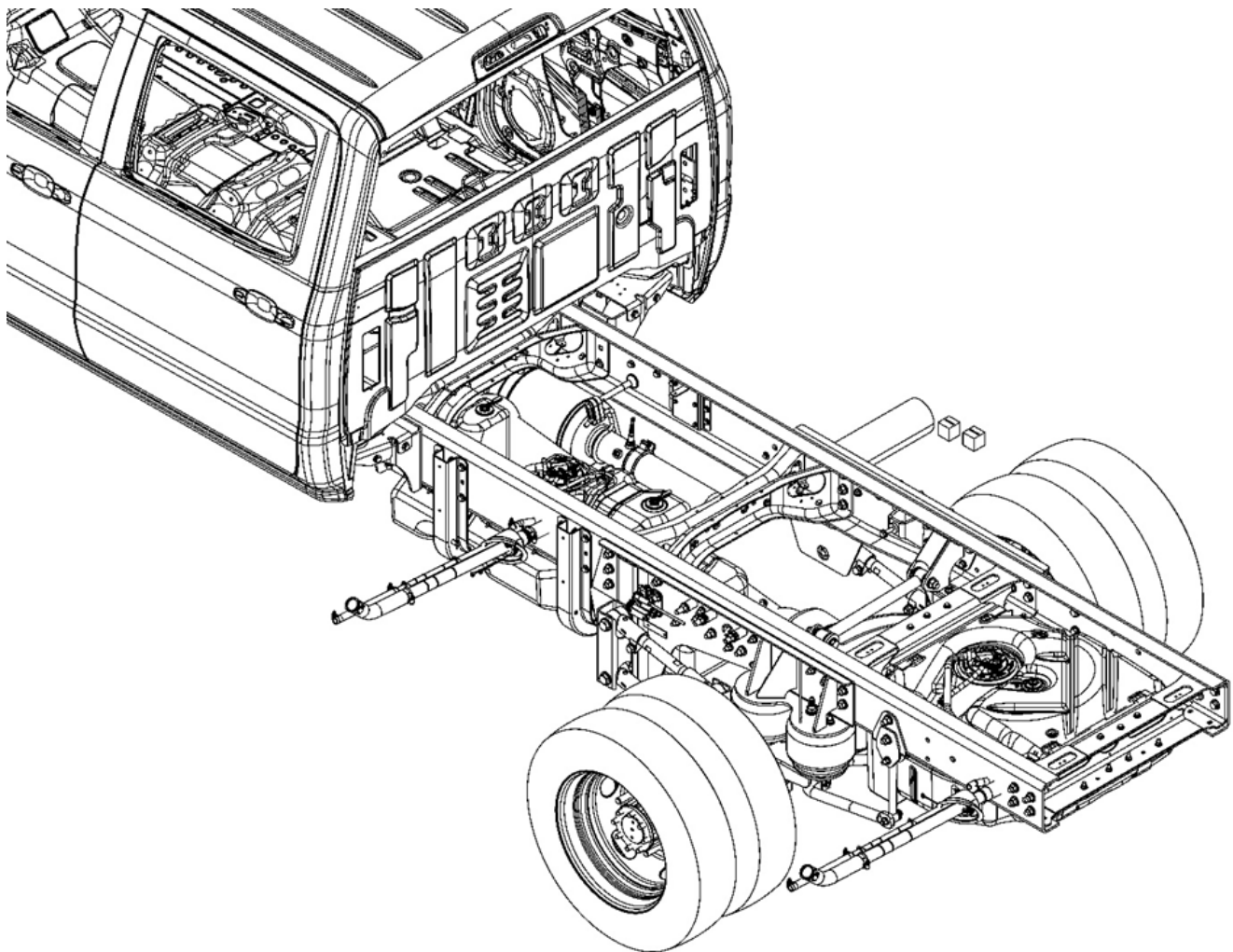

NOTES

NOTES

CONTACT INFORMATION

KELDERMAN MANUFACTURING APPRECIATES YOUR BUSINESS. WE STRIVE TO MEET THE NEEDS OF OUR CUSTOMERS BY PROVIDING THE HIGHEST QUALITY PRODUCTS. IF YOU HAVE ANY QUESTIONS CONCERNING OUR PRODUCTS PLEASE CALL OR EMAIL US AT THE FOLLOWING:

2686 HIGHWAY 92
OSKALOOSA, IOWA 52577

PHONE: [1-800-334-6150](tel:1-800-334-6150)

EMAIL: INFO@KELDERMAN.COM

kelderman



SCAN ME

SCAN QR CODE FOR KELDERMAN WARRANTY PAGE