

Welding required

3/8"-24 tap required

INSPECT CONTENTS
OF KIT PRIOR TO
INSTALL

VERSION 1.4

#10004409
#10005561



2686 Highway 92 - Oskaloosa, IA 52577
phone: 641.673.0468 email: info@kelderman.com
www.kelderman.com

2019+ Ram 3500 Stock/2-3" 4-Link Rear Air Suspension (Factory Air Ride & Leaf) Installation Instructions



Installation

1. Measure the pinion angle and record the angle here: _____. This is important because you will need to put the axle back to this measurement after the installation. You will need to also record the measurement from the front of the axle to a location on each side of the frame. Right side _____ Left side _____

NOTE: All the bolts in this kit use a flat washer on each side of the bolt. It is required to remove the truck bed for installation

2. Jack up the rear of the frame so that most of the tension is off the leaf springs. Place a set of jack stands under the frame, block the tires so the axle won't move, and place a jack stand under the pinion so it doesn't rotate. If the truck has the RAM factory air suspension, remove the airbags. Disconnect the air ride sensor linkage off the lower linkage mount. You will be able to use the Ram air management system or the Kelderman system once the install is complete. Remove the leaf springs.

3. You can install both sides at the same time if you have two people working on the truck. Locate the trailing arm mounts (Part # 10004407-DS and 10004514-PS) and the side plates (Part # 10005557-DS and 10005604-PS). The trailing arm mounts fasten to the forward OEM leaf spring perch with the front leaf spring bolt and the side plates fasten to the OEM front hitch mounts. *IF YOUR TRUCK HAS OVERLOAD PADS ON THE FRAME SEE THE NEXT PAGE.* You will fasten the side plate to the hitch mount with the factory 14mm bolts (if it doesn't have factory bolts use the 9/16" bolts and bushings provided). Frame support plates (10004410-DS & 10004518-PS) will attach to side plate and trailing arm mount.

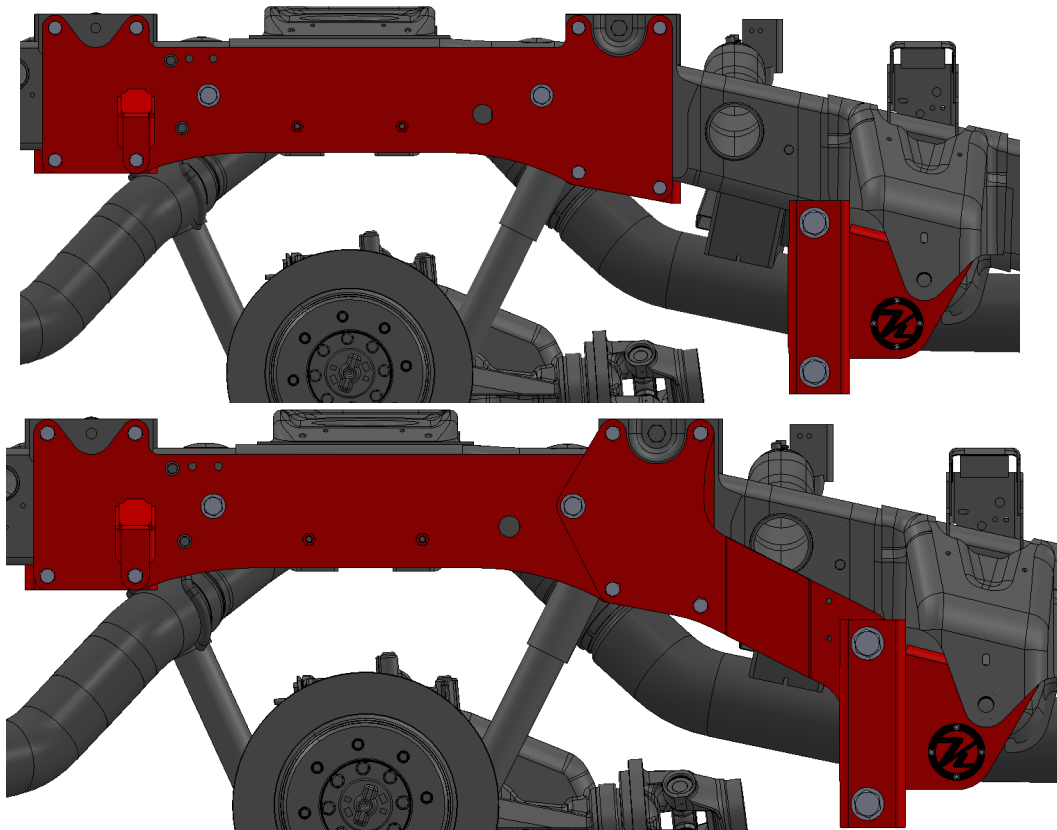

NOTE: If your truck has factory overload perches welded to the frame, both perches on each side will need to be removed. Use a cut off wheel on a grinder to cut the welds. Paint over ground area. Do not remove the rear leaf spring perch.

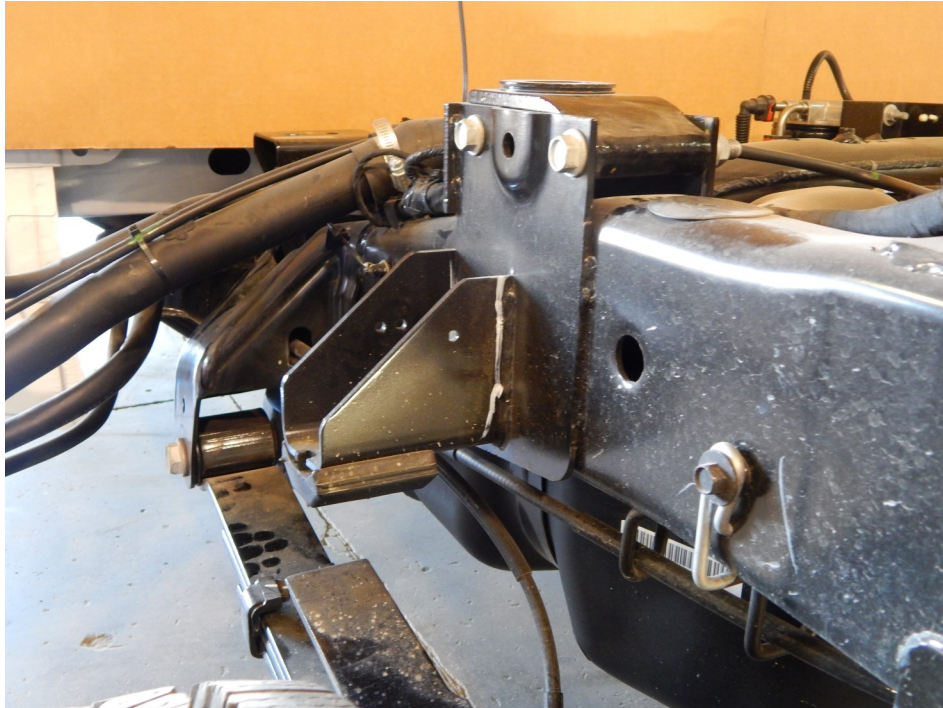

Overload perch shown removed from the frame.



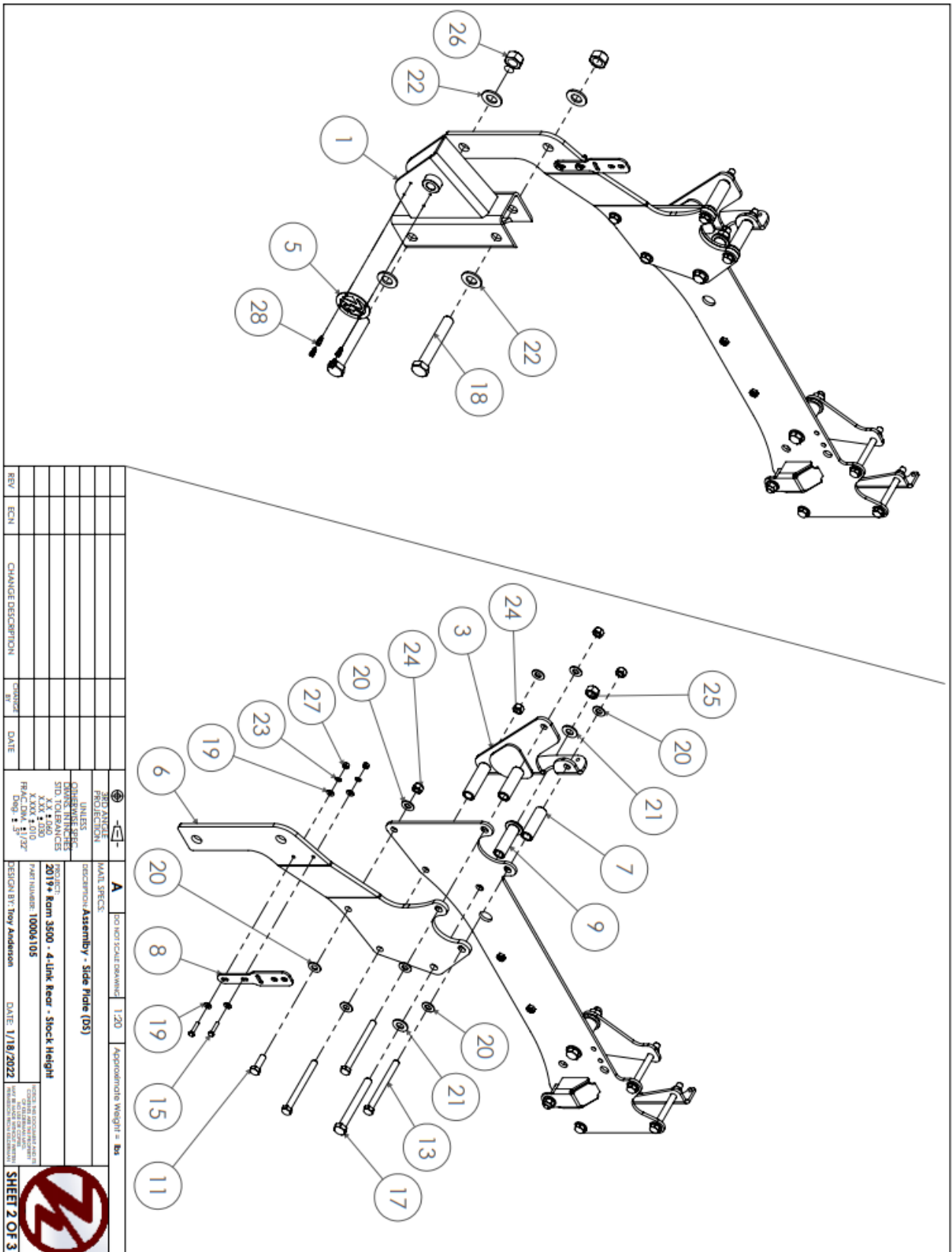

REV	ECN	CHANGE DESCRIPTION	DESIGNED BY	DATE				APPROXIMATE WEIGHT = Bx
					2D/3D PROJECTION	A DO NOT SCALE DRAWING	APPROXIMATE WEIGHT = Bx	
					UNLESS OTHERWISE SPECIFIED ALL DIMENSIONS ARE IN INCHES UNLESS OTHERWISE SPECIFIED DIMENSIONS IN PARENTHESES ARE IN MILLIMETERS	MATERIAL SPECIFICATIONS (SEE DRAWING FOR MATERIAL SPECIFICATIONS)	APPROXIMATE WEIGHT = Bx	
					DIMENSIONS IN PARENTHESES ARE IN MILLIMETERS	PROJECT 2019* Ram 3500 - 4 Link Rear - Stock Height	APPROXIMATE WEIGHT = Bx	
					TOLERANCES XXX ± .030 XXXX ± .010 XXXX ± .010 XXXX ± .010	PART NUMBER 10006105	APPROXIMATE WEIGHT = Bx	
					DATE 1/18/2022	DESIGN BY Troy Anderson	APPROXIMATE WEIGHT = Bx	
							APPROXIMATE WEIGHT = Bx	



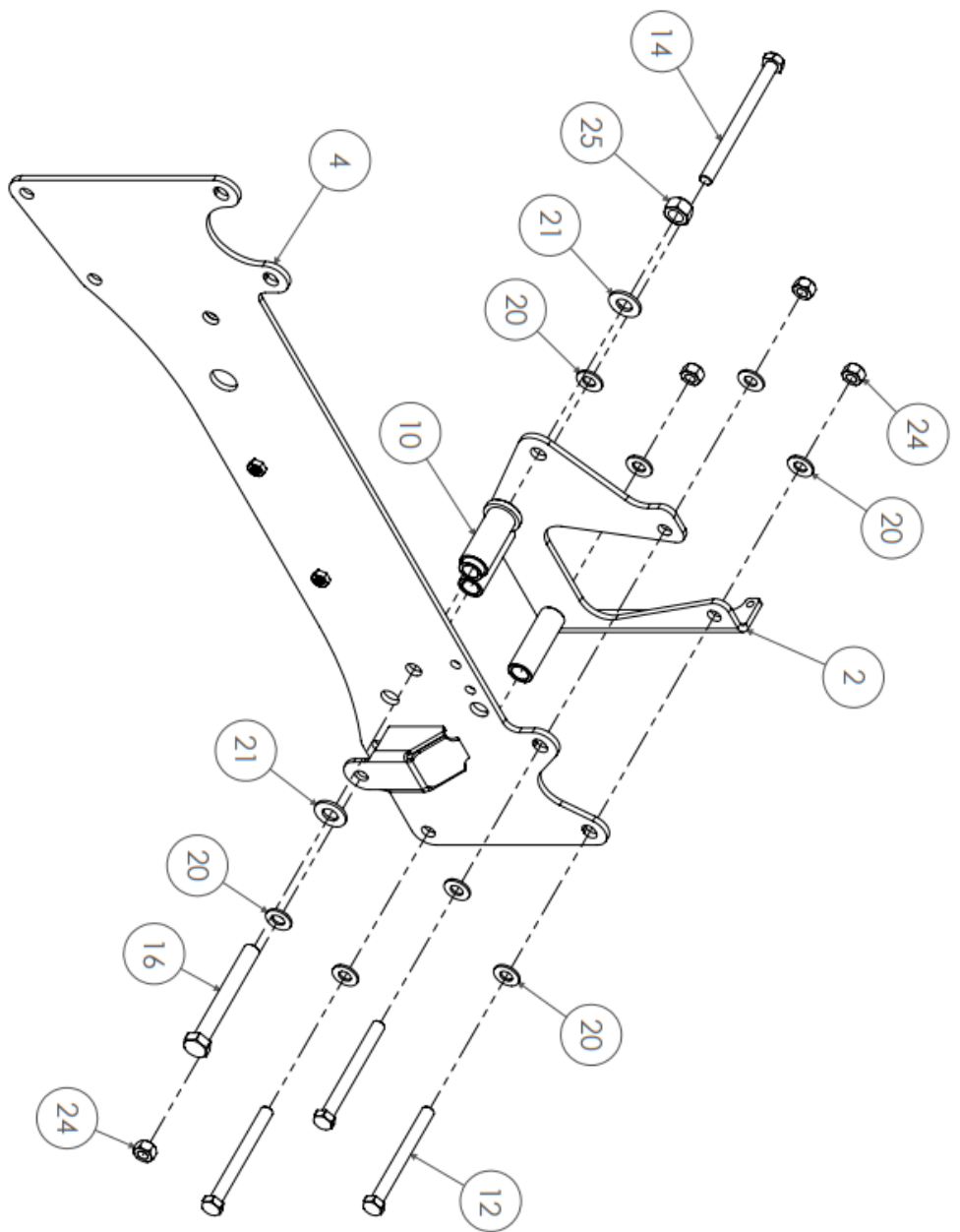

REV/	ECN/	CHANGE DESCRIPTION	DESIGNED BY	DATE	 2ND ANGLE PROJECTION	A 3D ISOTRAZ DRAWING	1:20	Approximate Weight = lbs
					UNLESS OTHERWISE SPECIFIED	DIMENSIONS IN INCHES DIMENSIONS IN MILLIMETERS UNLESS OTHERWISE SPECIFIED		
					DIMENSIONS IN INCHES DIMENSIONS IN MILLIMETERS UNLESS OTHERWISE SPECIFIED	PROJECT DESCRIPTION: Assembly - Side Frame (05)		
					DIMENSIONS IN INCHES DIMENSIONS IN MILLIMETERS UNLESS OTHERWISE SPECIFIED	PROJECT DESCRIPTION: 2019 Rom 3500 - 4 Link Rear - Stock Height		
					DIMENSIONS IN INCHES DIMENSIONS IN MILLIMETERS UNLESS OTHERWISE SPECIFIED	PART NUMBER: 10006105		
					DIMENSIONS IN INCHES DIMENSIONS IN MILLIMETERS UNLESS OTHERWISE SPECIFIED	DESIGN BY: Troy Anderson	DATE: 1/18/2022	

SHEET 3 OF 3

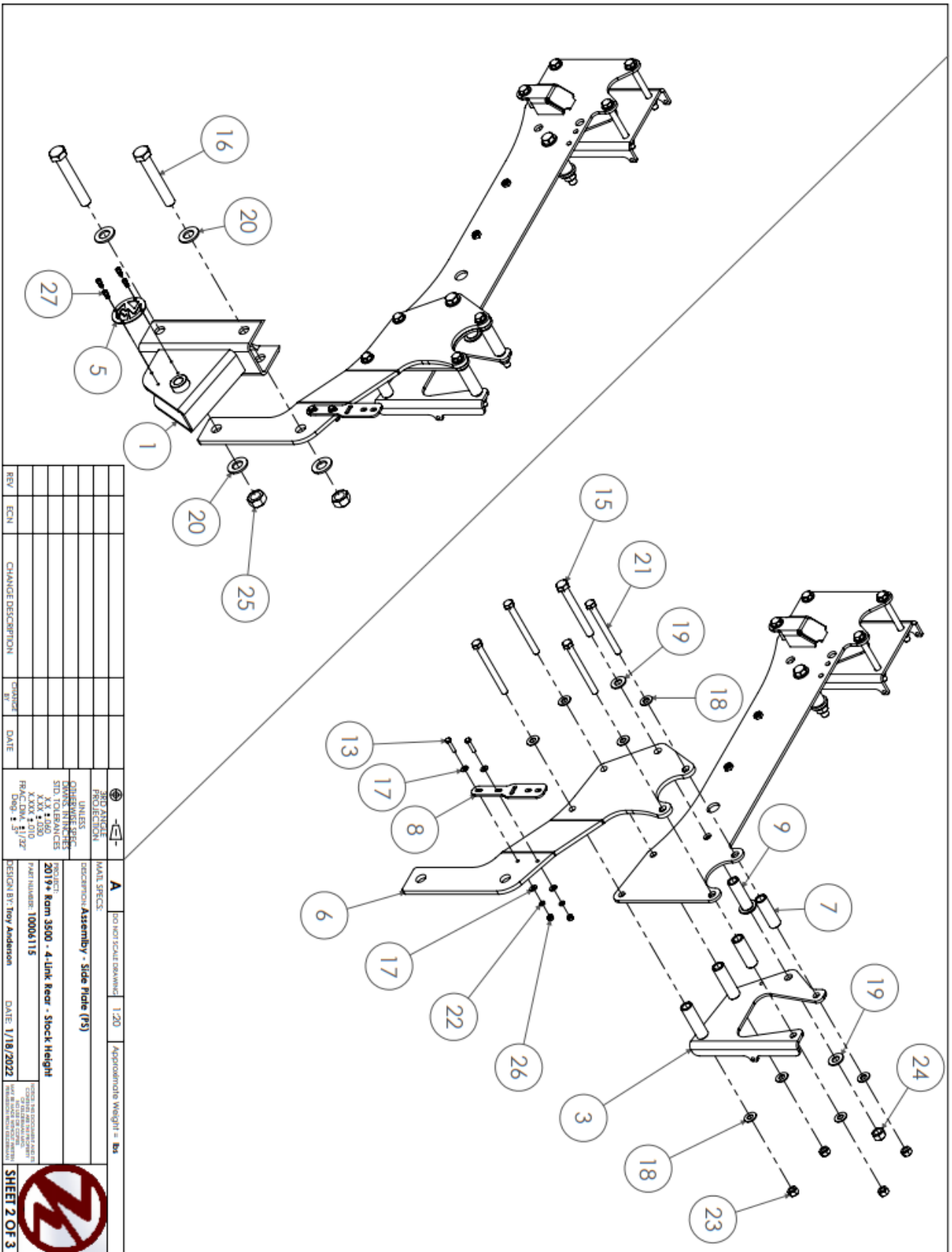

4. Locate the lower air bag mounts (Part # 10004557-DS and 10004424-PS). They will fit on the axle pad and the OEM air bag mount on the axle. If you have factory air, then will have to drill (4) holes in the lower bag mount. Set the lower bag mounts in place and mark where to drill on the lower OEM lower bag mounts. Drill these holes out to 3/4". You may have to use a die grinder to oblong the holes if the bolts don't drop straight down and slide into the lower axle clamps (Part # 10004647). Do not install the lower bag mounts yet. You will do that in step 7.

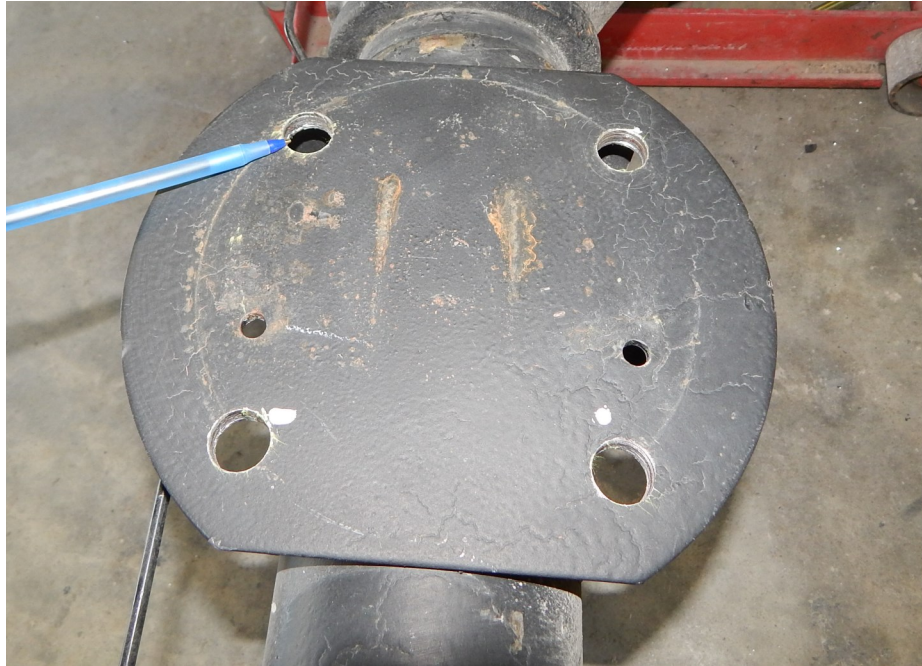

NOTE:

On the 2-3" kit, you will install a 2" spacer in between the air bag and the lower bag mount.

5. Locate the upper pan hard bar mount (Part # 10009640) and pan-hard bar bolt plate (Part # 10004553). The upper pan hard bar mount fastens inside the frame/hitch area on the passenger side. Remove the passenger side bolt plate that fastens the hitch in place. Slide the mount up from the bottom and use the 1/2" x 1" bolts and flat washers to fasten the lower part of the mount to the frame. Slide the new bolt plate from the top down and torque the bolt plate nuts to 150 ft./lbs. Torque the 1/2" bolts to 85 ft./lbs. Drill two 3/8" holes through the frame of the truck. You will see a couple holes that are just under 3/8". Drill up through the bottom of the frame. Be careful when drilling. You are going through the frame and then up through the holes in the pan-hard bar mount. Use caution while drilling as the drill may snag. **NOTE:** If the truck has an aftermarket fifth wheel hitch, you may have to trim outer part of the mount back. It is designed off the OEM hitch system. Non-factory hitches will use a frame spacer (Part # 10004890)

6. Locate the upper air bag mounts (Part # 10005602-DS and 10005602-PS). The large notch is to be orientated towards the outside of the truck. On the passenger side you will need to place the holes so they line up with the holes in the lower plate on the pan-hard bar bracket. Run the (2) M10-4.5 x 45 socket cap screw bolts up from the bottom of the air bag mount (use the countersunk holes) through the frame and through the plate on the lower pan-hard bar mount. Use the lock nut to snug the bolt. Re-use the factory bolts that held the OEM airbag in place to fasten the outer two holes in the air bag bracket to the frame. NOTE: On non air ride trucks, the air bag mounting bolts are not there. You will need to weld the outside of the air bag bracket to the frame. Grind the powder coat and paint off the frame and lay a 3" weld. Once all the bolts are in place, torque the inner bolts to 45 ft./lbs. and the outer bolts to 85 ft./lbs. The drivers side installs the same way, minus fastening through the pan-hard bar mount.

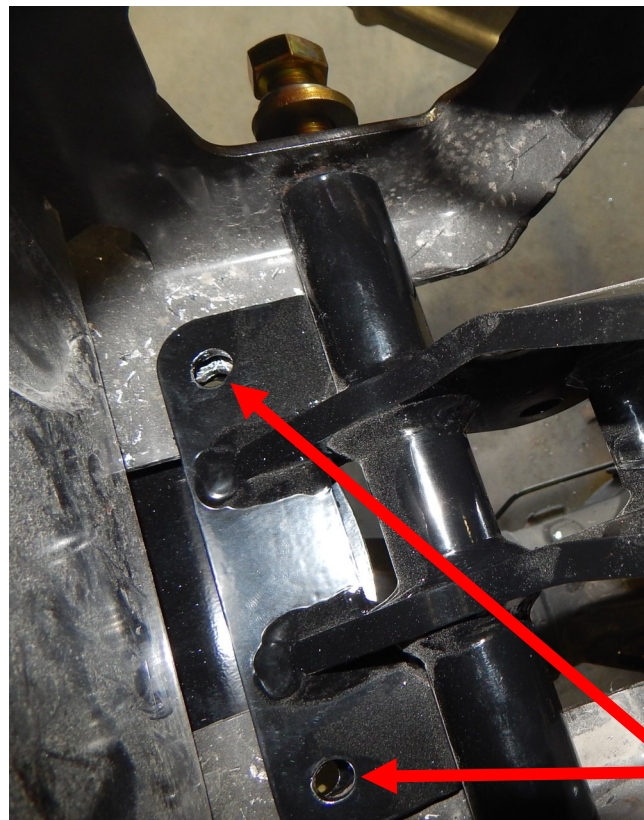

Drill the small hole in the frame out to 3/8"

Drivers side upper bag mount installed

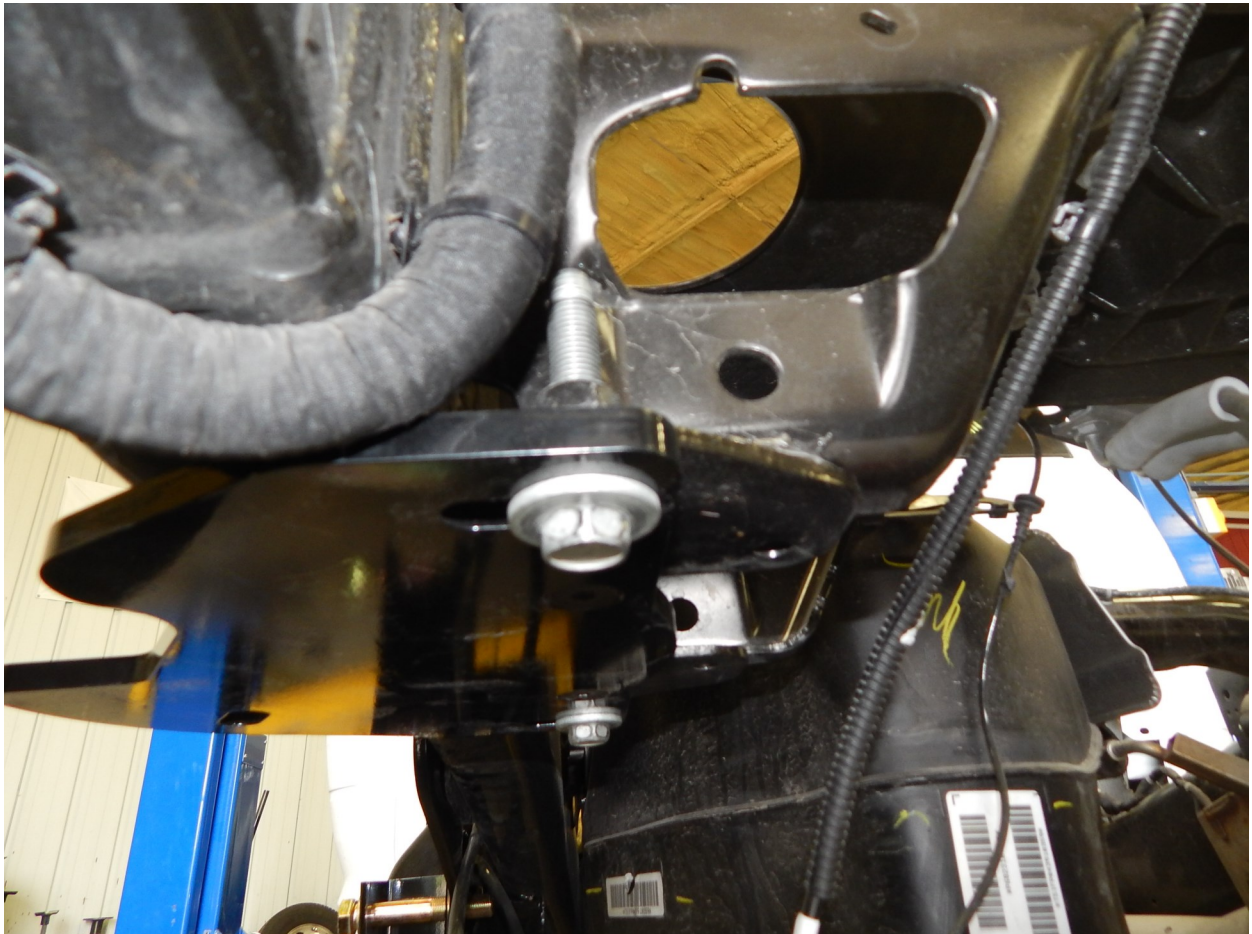
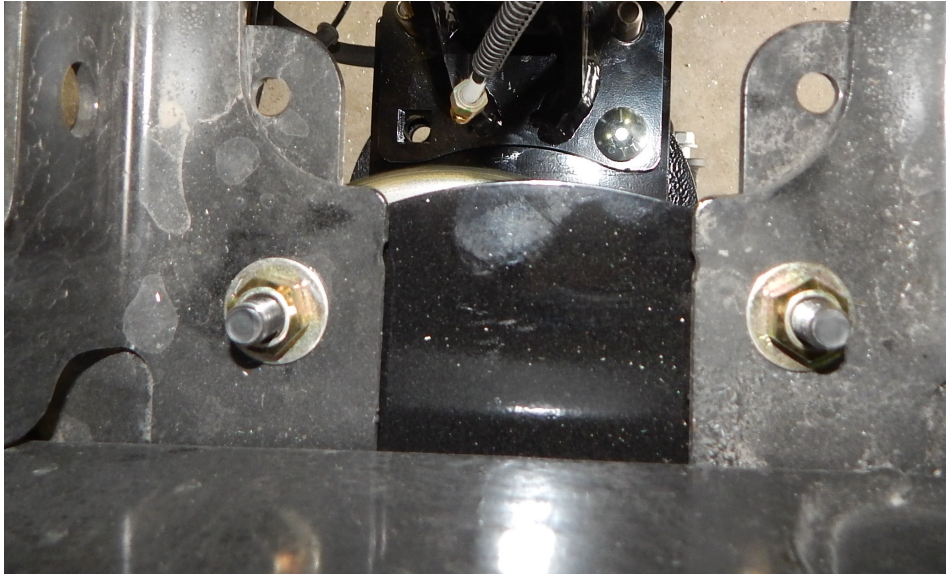

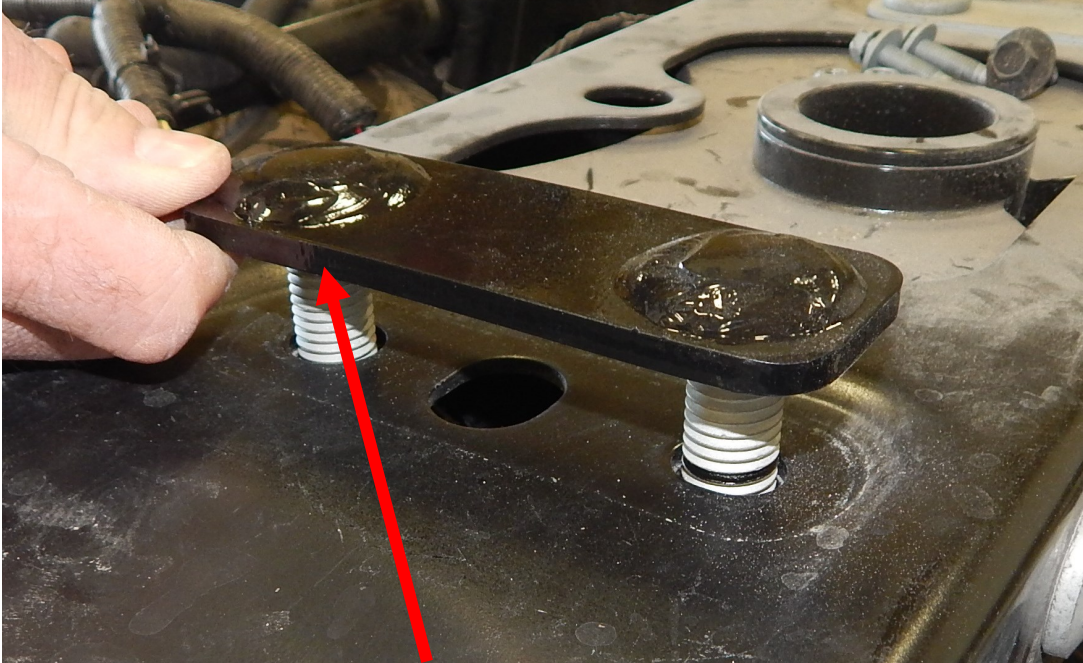

Panhard bar bolt plate replaces OEM bolt plate (passenger side)



7. Locate the lower air bag mounts (Part # 10004557-DS and 10004425-PS), lower axle clamps (Part # 10004647), (2) U-bolts (Part # 14114) and air bags (Part # F5748). The lower air bag mount fastens on top of the leaf spring perch and clamps to the axle with the U-bolts and (4) 5/8" x 8-1/2" bolts. Drop the (4) 5/8" bolts through the lower bag mount. Place the air bag on top of the lower bag mount. Snug the stud up on the bottom of the air bag with the 3/4" lock washer and nut. NOTE: Position the air bag so the large port in the air bag will line up with the cut out in the upper bag mount and the small hole in the upper bag mount will line up with the threaded hole in the air bag. You can torque the stud on the bottom of the air bag once the install is complete. It just needs to be snug for now. Do not torque the 5/8" bolts or U-bolts until after the cross-member is installed in step 8. Locate the air fitting for the air bag and fasten it into the air bag so the large air fitting points towards the rear of the truck. You will connect the port to the accumulator tank in step 12.

Air bag is oriented so the hole lines up with the air bag threaded hole

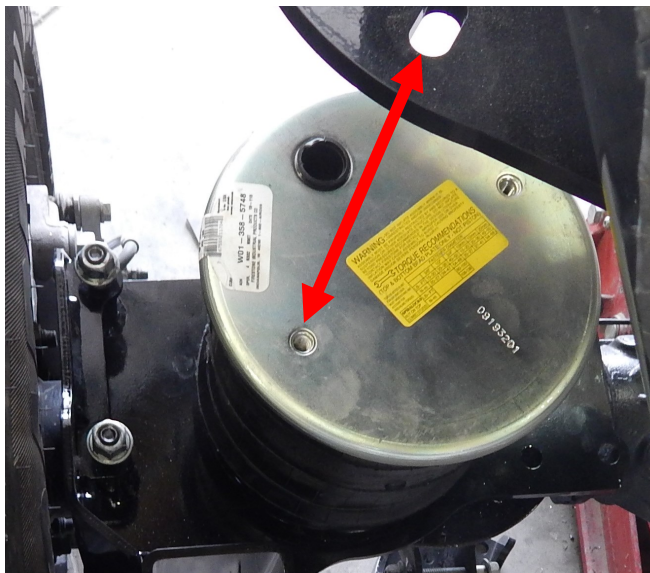

Fitting oriented towards rear of truck

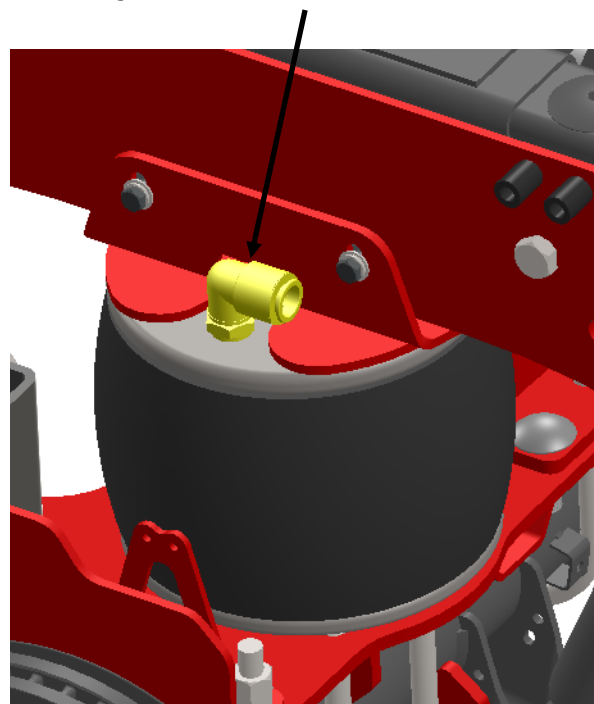

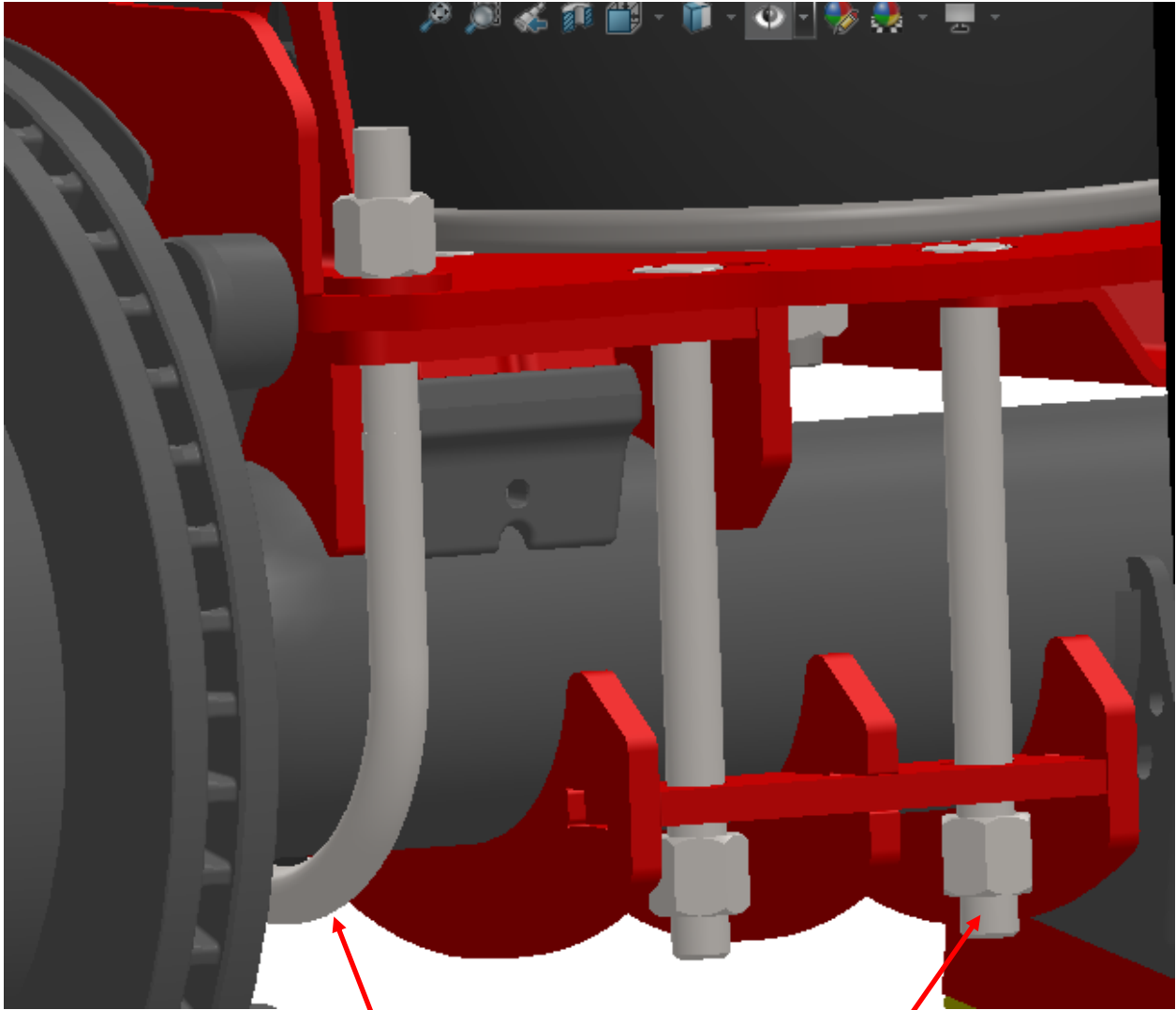

U-Bolt (Part # 14114) Nut (Part # 13179)

5/8" x 8-1/2" Bolts (Part # 12451) Nut (Part # 13179)

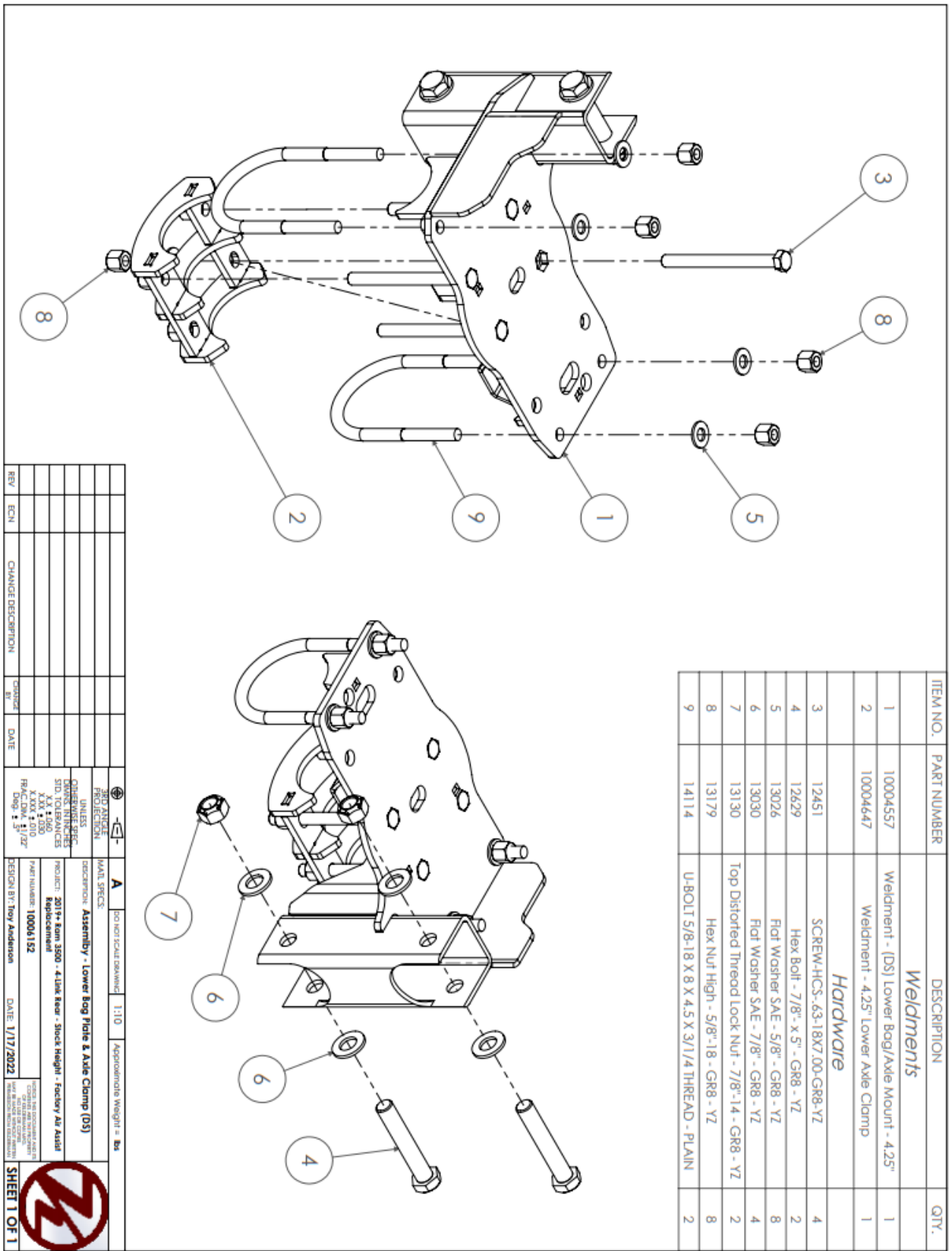

ITEM NO.	PART NUMBER	DESCRIPTION	QTY.
1	10004557	Weldment - (DS) Lower Bag/Axle Mount - 4.25"	1
2	10004647	Weldment - 4.25" Lower Axle Clamp	1
		Hardware	
3	12451	SCREW-HCS-.63-18X7.00-GR8-YZ	4
4	12629	Hex Bolt - 7/8" x 5" - GR8 - YZ	2
5	13026	Flat Washer SAE - 5/8" - GR8 - YZ	8
6	13030	Flat Washer SAE - 7/8" - GR8 - YZ	4
7	13130	Top Distorted Thread Lock Nut - 7/8"-14 - GR8 - YZ	2
8	13179	Hex Nut High - 5/8"-18 - GR8 - YZ	8
9	14114	U-BOLT 5/8-18 X 8 X 4.5 X 3/1/4 THREAD - PLAIN	2

REV	ECN	CHANGE DESCRIPTION	CHANGED BY	DATE	FRONT ANGLE PROJECTION	UNLESS OTHERWISE SPECIFIED DIMENSIONS ARE IN INCHES DECIMAL FRACTIONS XX.XX ± .030 FRACTIONS 1/16" ± 1/32"	MATERIAL SPECIFICATIONS	DESCRIPTION	SCALE	APPROXIMATE WEIGHT - LBS	DESIGN BY	DATE	SHEET 1 OF 1
								2017+ Kom 3500 - 4 Link Rev - Stock Height - Factory Air Assist Reprovements	1:10		10004152	1/17/2022	

8. Locate the lower pan-hard bar crossmember (Part # 10009769). It fastens to the lower air bag mounts with the 5/8" U-bolt and (4) 5/8" carriage bolts. Torque the U-bolts to 100 ft./lbs. Torque the 5/8" bolts to 55 ft./lbs. You may now torque the U-bolt on the outer ends of the lower bag mount to 125 ft./lbs. and torque the 5/8" x 8-1/2" bolts to 150 ft./lbs.

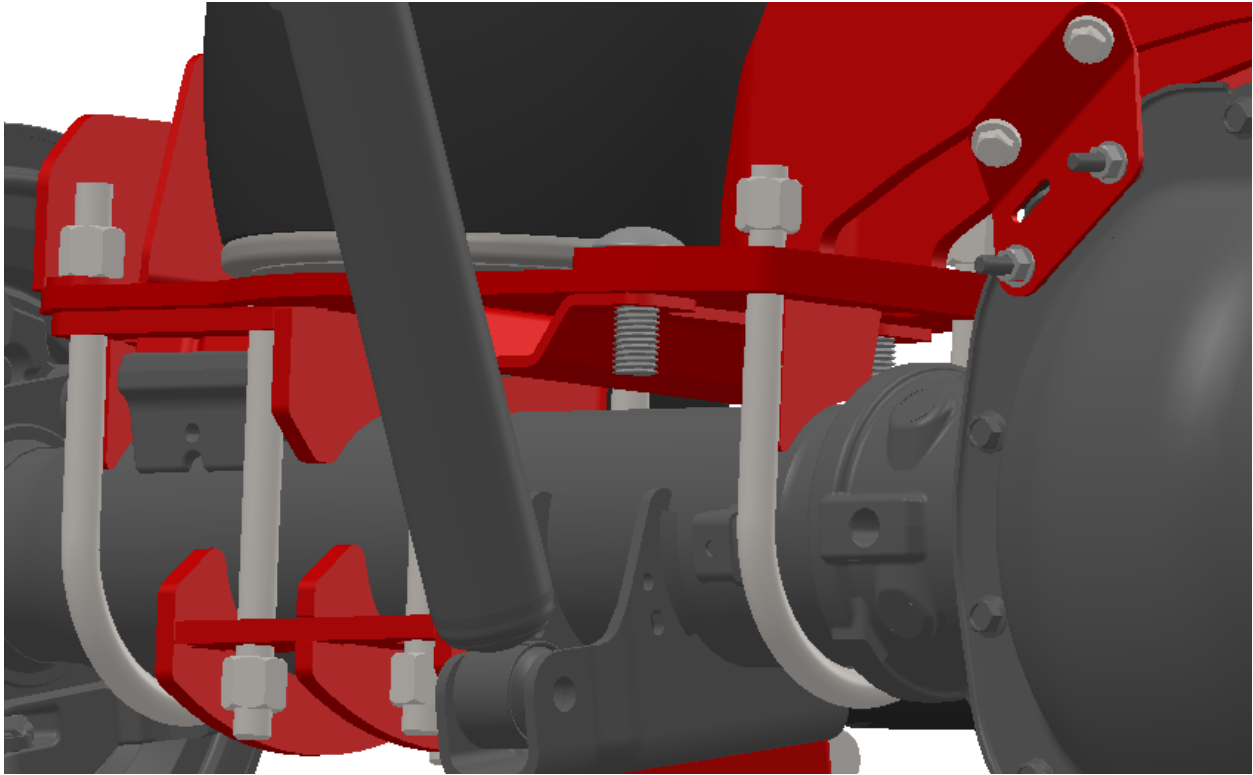

U-Bolt (Part # 14114) Nut (Part # 13179)

ITEM NO.	PART NUMBER	DESCRIPTION	QTY.
		<i>Parts</i>	
1	10004450	Round Bar - 1-1/4" - PH8 Drop Mounting Bushing	1
2	10004558	Plate - 1/4" - Internal PH8 Bracket	1
3	10004996	Plate - 3/8" - Gusset Ear	2

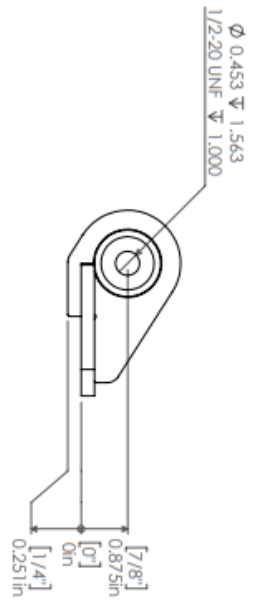
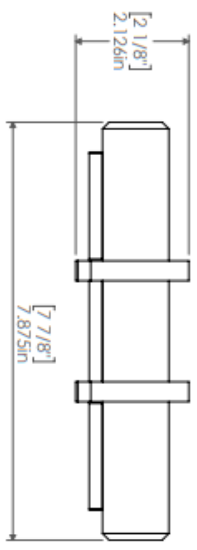
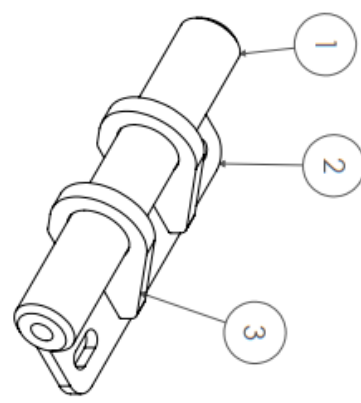
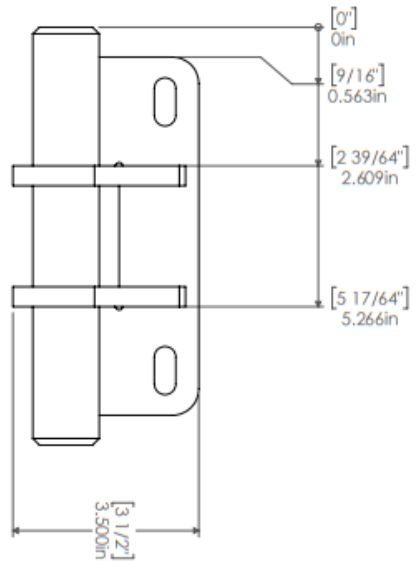

REV	ECN	CHANGE DESCRIPTION	DESIGNED BY	DATE	TA	10/6/20	1/27	1.5	Approximate Weight = lbs
B		Thread Changed to 1/2"-20							



SHEET 1 OF 1

9. Locate the trailing arms (Part # 52116) & Knuckles (Part # 10005/10006). NOTE: the trailing arm bars and knuckles will most likely be pre-assembled. Adjust the trailing arms so there is approximately 9" between the knuckles. The trailing arms will fasten into the forward trailing arm mounts and lower air bag mounts with the 7/8" x 5-1/2" bolts. Insert the bolts on the trailing arms so the bolt heads are on the outside on the mounts. Larger, wider tires may hit the bolts if mounted inside out.



Knuckle #10006

Knuckle #10005

Trailing arms shown installed at 9" in between knuckles

Trailing arms shown installed into forward mount and lower air bag mount



10. Locate the accumulator tanks (Part # 10005063). The tanks fasten into the rear leaf spring perch. Position the tank so the large port faces towards the front of the truck. Fasten the tank in place with the factory rear leaf spring shackle bolt. Torque this bolt to 150 ft./lbs.

11. Locate the 3/4" air line. Lay the air line besides the fitting on the air bag and the accumulator tanks. Be sure to add some extra length to the air line and cut it to fit between the airbag and tank. Remember that the air line will press into the fittings. Once the air line is cut, connect the accumulator tank to the air bag. If you have a factory air ride, you must use (80029) to connect the hose to 1/4 airline tube of the accumulator tank.



12. Locate the upgraded sway bar (Part # 80246), the sway bar D-ring brackets/bushings (Part # 80255/80258), the sway bar end links (Part # 17091) and sway bar drop spacers (Part # 10004769/10005463). The sway bar installs on the bottom of the shock mounts with the (2) 1/2" & (1) 1/4" spacers on each side and the 3/8" x 2-1/2" bolt. If your truck has the overload pads on it, remove the plastic contact pad. Use a 1/2" drill bit or die grinder and oblong the hole front to rear. Insert the end link stud up through the hole using the flat washer and rubber bushing on the end link. Install a rubber bushing on the overload pad and place a flat washer on top. You will tighten with the 1/2" nut. If your truck doesn't have the factory overload pads, you will use the upper sway bar mounts to the two factory hitch brackets. You will have to weld the side of the upper sway bar bracket to the side of the frame. A couple 3" down hand welds will be sufficient. Make sure to grind the paint off the frame and the powder coat off the bracket before you weld.

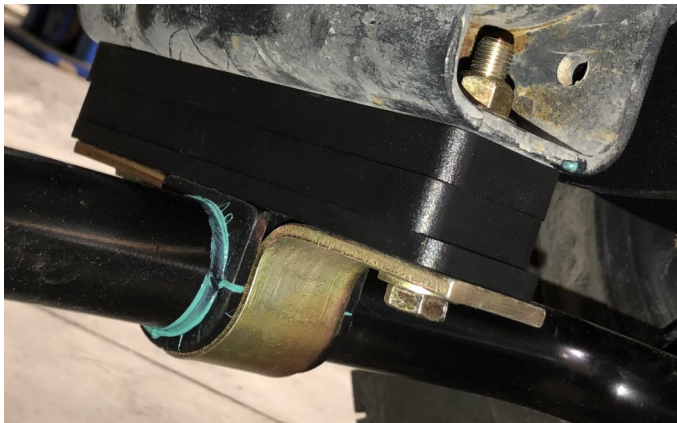

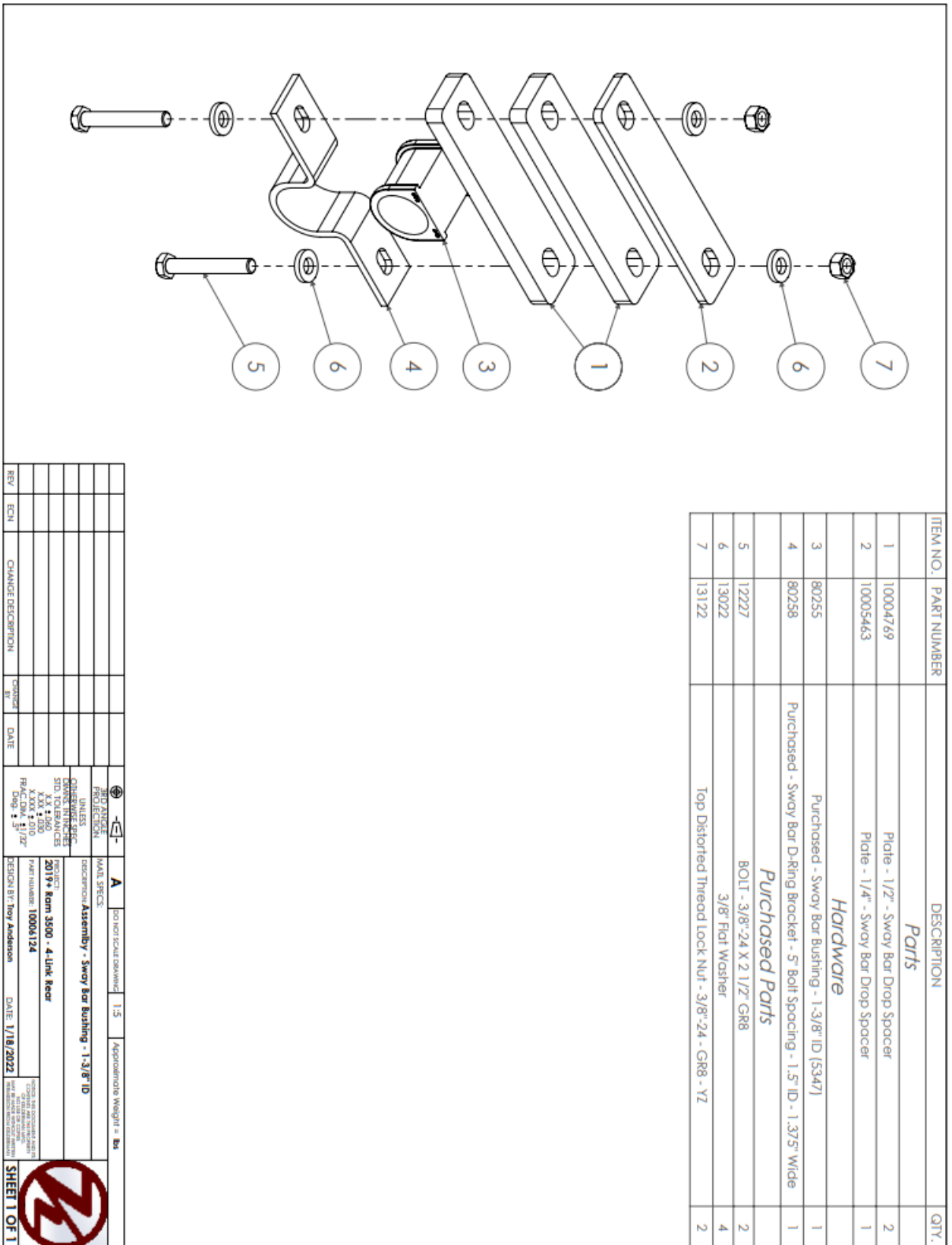

ITEM NO.	PART NUMBER	DESCRIPTION	QTY.
1	10004769	Plate - 1/2" - Swoy Bar Drop Spacer	2
2	10005463	Plate - 1/4" - Swoy Bar Drop Spacer	1
3	80255	Purchased - Swoy Bar Bushing - 1.3/8" ID (5347)	1
4	80258	Purchased - Swoy Bar D-Ring Bracket - 5" Bolt Spacing - 1.5" ID - 1.375" Wide	1
5	12227	BOLT - 3/8"-24 X 2 1/2" GR8	2
6	13022	3/8" Flat Washer	4
7	13122	Top Distorted Thread Lock Nut - 3/8"-24 - GR8 - VZ	2

REV	ECN	CHANGE DESCRIPTION	ISSUED BY	DATE

PART ANGLE: **A** DO NOT SCALE DRAWING 1:5 Approximate Weight = lbs
 PROJECTION: **A**
 UNLESS OTHERWISE SPECIFIED
 DIMENSIONS ARE IN INCHES
 DIMENSIONS IN PARENTHESES ARE IN MILLIMETERS
 TOLERANCES ARE AS SHOWN
 FINISH: XXXX +010
 FRACTION: 1/16"
 DECIMAL: 0.0005
 PROJECT: 20199 Rom 3500 - 4 Link Rear
 PART NUMBER: 10004124
 DESIGN BY: Troy Anderson DATE: 1/18/2022
 CHECKED BY: [Signature]



13. End links (17091) attaches to side plates (10005604-PS & 10005576-DS) with 1/2"-20 x 6-1/4" bolts, 1/2" washers and 1/2"20 lock nut.



14. Locate the optional air control box and air dryer. The controls box fastens to the inside of the frame on the passenger side. You can also mount it where the spare tire goes if you wish, then the spare tire cannot be re-installed. There are (2) brackets (Part # 15140) that you will need to weld to the frame. Once the brackets are welded to the frame, attach the air compressor box to the brackets with the supplied 3/8" x 1" bolts and nuts. The air dryer bracket (Part# 30256) also needs to be welded to the side of the frame. The dryer attaches with factory dryer hardware. The air tank will also be mounted to the side of the frame. If you are not running retractable running boards, then tank can be mounted to outside of frame. Drill & tap (4) 3/8"-16 holes and bolt to the frame with (4) 3/8"-16 x 1" bolts.

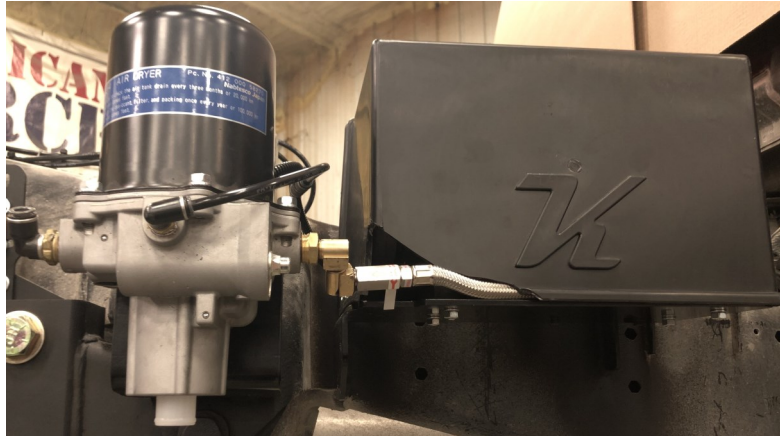

15. Once you have the air tank and air box mounted, locate the height control valves. They fasten to the sensor mounting brackets on the side plates with the 1/4" bolts. You will want to install the height control valve so the lever is straight out from the body when the air bag is at 7" tall. You will use a Phillips screwdriver to attach the collar to the upper trailing arm straight down under the end of the ball of the height control lever. With the height control valves installed, use the wiring and plumbing instructions provided with the air controls to finish the installation. Once completed, it will require some fine tuning to get the truck level side to side. Loosen the nut on the side of the lever and rotate up or down accordingly. A test drive will need to be done to get the final ride height determined.

Fine tune adjustment nut



16. If you choose to run the factory air controls, you will need to space the factory sensor out away from the frame 3/4" with the provided spacers (10010290). You will also need to attach the lower end link bracket (10010287) to the lower air bag mount. The ideal ride height for the air bag is 7". Ram trucks may or may not warranty any of their components once their factory system is removed.

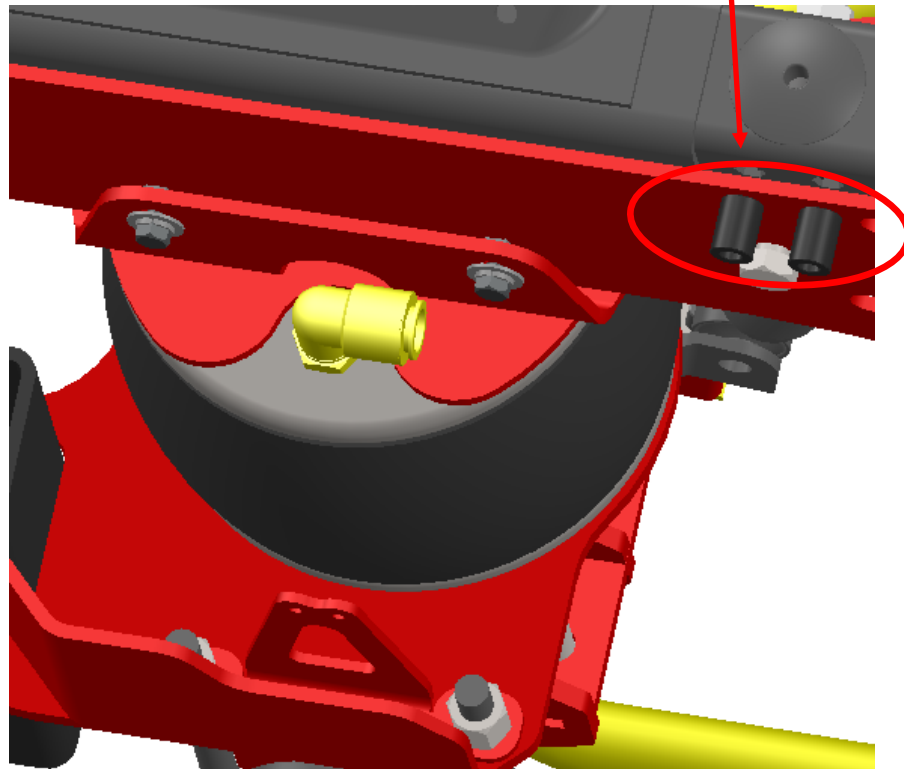
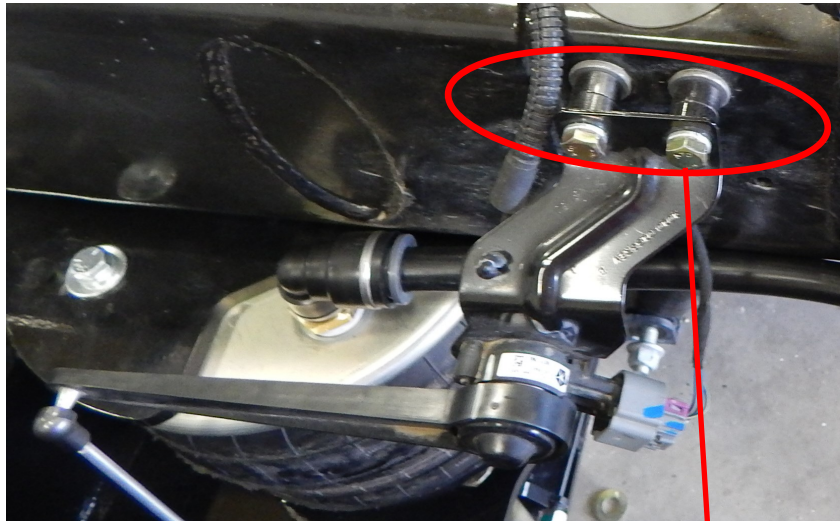

ITEM NO.	PART NUMBER	DESCRIPTION	QTY.
<i>Assemblies</i>			
1	17091	USE PDM MODEL - Weldment - 18.00" End-Link	2
2	18498	Assembly - Cast Knuckle 10006	4
3	18499	Assembly - Cast Knuckle 10005 - 1" ID	4
4	10005062	Weldment - Accumulator Tank - 1 gal. (PS)	1
5	10005063	Weldment - Accumulator Tank - 1 gal. (DS)	1
6	10005591	Assembly - Upper Bog Plate	1
7	10005603	Assembly - Upper Bog Mount & PHB Drop (PS)	1
8	10006097	Assembly - PHB Crossmember - Stock Height	1
9	10006105	Assembly - Side Plate (DS)	1
10	10006115	Assembly - Side Plate (PS)	1
11	10006124	Assembly - Sway Bar Bushing - 1-3/8" ID	2
12	10006125	Assembly - Brick Line Relocation Bracket (Bent) - 1-3/4" Extension	1
13	10006152	Assembly - Lower Bog Plate & Axle Clamp (DS)	1
14	10006153	Assembly - Lower Bog Plate & Axle Clamp (PS)	1
15	10009775	Assembly - Panhard Bar - 18" Bar Length - 3/4" Bolt	1

ITEM NO.	PART NUMBER	DESCRIPTION	QTY.
<i>Parts</i>			
16	11551	Plate - 1/4" - 1.5"OD x .53" ID x 1/4"	2
17	17551	Plate - 18ga - Wire/Hose/Brake Cable Retainer	1
18	51707	Plate - 7ga - Sensor Arm - 7.5" - Straight	2
19	52116	16.00" Trailing Arm Bar	4
20	10004891	Tube - 1" OD x 0.687" ID x 3" L - Fifth Wheel For Anti-Crush Bushing	2
21	10010287	Plate - 7ga - OE Height Control Sensor - Ball Stud Bracket - Axle	2
22	10010290	Bushing - .75" OD x .39" ID - OE Height Control Stand-Off	4
<i>Purchased Parts</i>			
23	80094	90° Male Elbow Tube 1/4" x 1/4-18 NPT	2
24	80246	Purchased - Sway Bar - 1-3/8" Dia	1
25	80261	45° Male Elbow, 3/4" x 3/4" - 14 NPT - Brass Fitting, Swivel	2
26	80264	Purchased - Vibration-Damping Loop Clamp - 1/2" ID	2

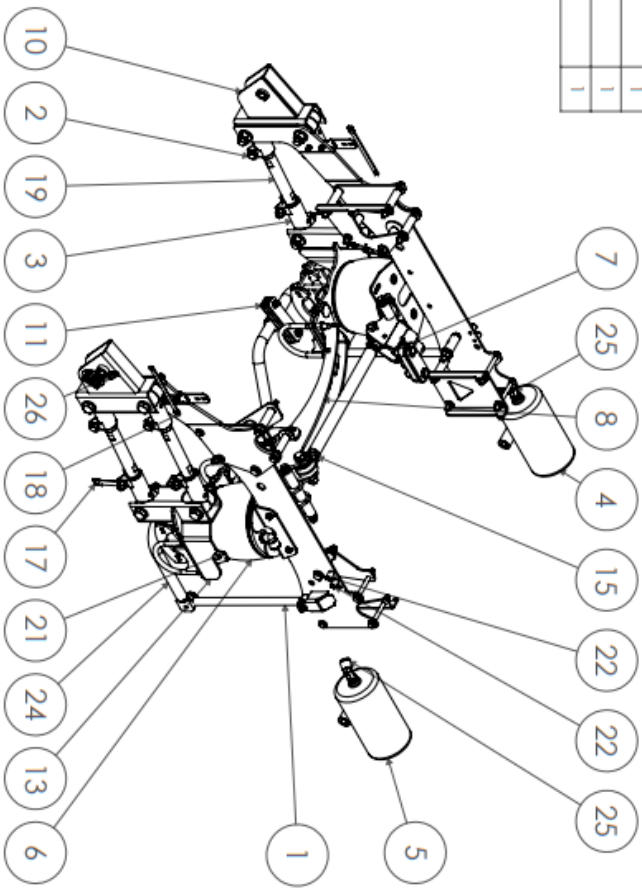

REV	ECN	CHANGE DESCRIPTION	Changed By	DATE	3RD PARTY PROVISION	3RD PARTY APPROVAL	DATE	APPROXIMATE WEIGHT = lbs
A		DO NOT SCALE DRAWING						1.50
B		OE Height Control Brackets	TA	8/6/21				
C		Johnny Joint PHB Conversion	TA	5/27/21				
D								
E								
F								
G								
H								
I								
J								
K								
L								
M								
N								
O								
P								
Q								
R								
S								
T								
U								
V								
W								
X								
Y								
Z								
AA								
AB								
AC								
AD								
AE								
AF								
AG								
AH								
AI								
AJ								
AK								
AL								
AM								
AN								
AO								
AP								
AQ								
AR								
AS								
AT								
AU								
AV								
AW								
AX								
AY								
AZ								
BA								
BB								
BC								
BD								
BE								
BF								
BG								
BH								
BI								
BJ								
BK								
BL								
BM								
BN								
BO								
BP								
BQ								
BR								
BS								
BT								
BU								
BV								
BW								
BX								
BY								
BZ								
CA								
CB								
CC								
CD								
CE								
CF								
CG								
CH								
CI								
CJ								
CK								
CL								
CM								
CN								
CO								
CP								
CQ								
CR								
CS								
CT								
CU								
CV								
CW								
CX								
CY								
CZ								
DA								
DB								
DC								
DD								
DE								
DF								
DF								

PROJECT: **John 3500 - 4-link Rear - Shock Height - Factory Air Assist Replacement**
 PART NUMBER: **10004409**
 DATE: **1/18/2022**

Compressor Box Self-Leveling Kit Wiring Diagram (ambulance prep package)

