



KLM 69210

Version 1.1

17/32" drill bit required

kelderman[®]

2686 Highway 92 - Oskaloosa, IA 52577

phone: 641.673.0468 - fax: 641.673.4168

www.kelderman.com

2017+ Ford F-450/F-550 Chassis Cab 4-Link Rear Installation Instructions

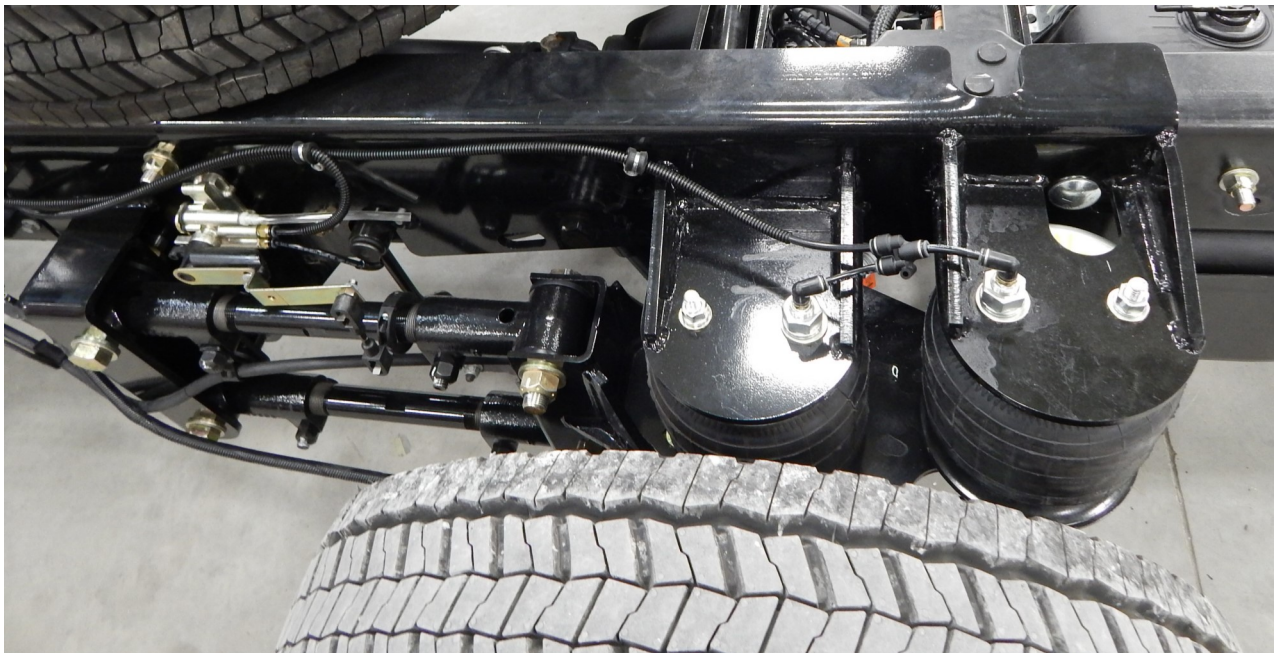

TABLE OF CONTENTS

INSTALLATION INSTRUCTIONS INDEX

- INTRODUCTION.....pg. 3
- EXPLODED ASSMBLIES AND PARTS LIST.....pg. 4-8
- PRE-INSTALLATION CHECKLIST.....pg. 9-10
- DISASSEMBLY.....pg. 11
- INSTALLATION.....pg. 12-19
- AIR CONTROL SYSTEM.....pg. 20-22

OPERATOR INSTRUCTIONS INDEX

- FINAL INSPECTION CHECKLIST.....pg. 23
- OPERATION GUIDELINES.....pg. 24
- SERVICE & MAINTENANCE.....pg. 25

MISCELLANEOUS INFORMATION

- TORQUE TABLE & DIMENSION SHEET.....pg. 26
- OWNERS GUIDELINES.....pg. 27
- ELECTRICAL SCHEMATIC.....pg. 28-29
- TROUBLE SHOOTING GUIDE.....pg. 30
- WIDEST POINT DIAGRAM.....pg. 31



INTRODUCTION

IMPORTANT!

It is important that the entire installation instructions be read thoroughly before proceeding with suspension installation.

PRODUCT INSTALLER RESPONSIBILITIES

Installer is responsible for installing the product in accordance with Kelderman Mfg., Inc. specifications and installation instructions.

Installer is responsible for providing proper installation of vehicle components and attachments as well as required or necessary clearance for suspension components, axles, wheels, tires, and other vehicle components to ensure a safe and sound installation and operations.

Installer is responsible for advising the owner of proper use, service, and maintenance required by the product and for supplying maintenance and other instruction as readily available from Kelderman Mfg., Inc.

WARNING!

A correct installation must result in the suspension and axle being "loaded" within the range specified by axle and suspension manufacturers. Please check vehicle specifications and intended usage to insure axle will be within Gross Weight Rating (GAWR). No alteration of any suspension component is permitted.

DEFINITION OF TERMS

WARNING –indicates a potentially hazardous situation which, if not avoided, could result in death or serious injury.

CAUTION –a potential hazardous situation may result in property damage.

NOTE –provide information or suggestions that help you correctly perform a task.

TORQUE –the italicized torque alerts you to tighten fasteners to a specified torque value.



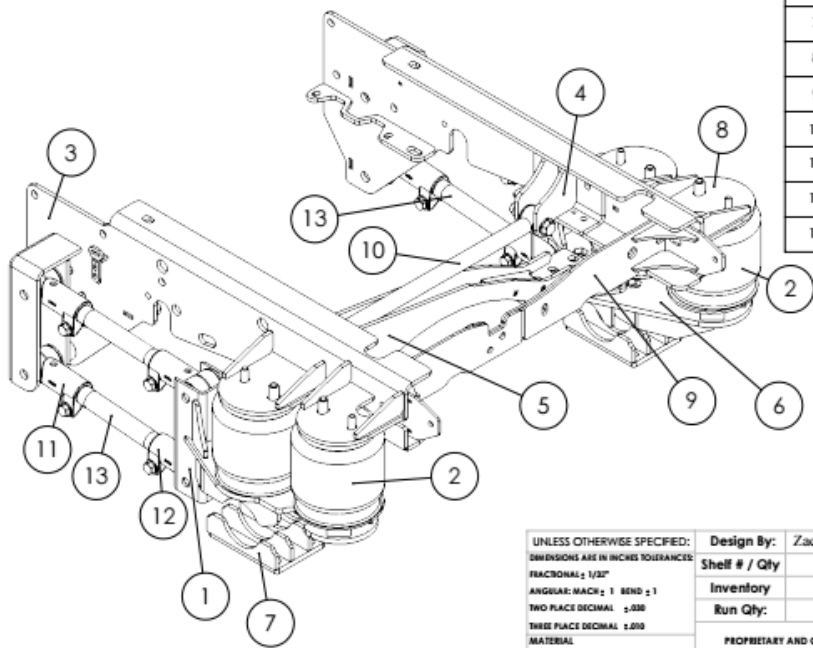

ITEM NO.	PART NUMBER	DESCRIPTION	Default/QTY.
1	69225	(DS) Lower Bag Mount	1
2	80012-5323	Firestone 5323	4
3	69193	(DS) Upper Bag / Frame Mount	1
4	69208	(PHB) Upper Bracket (3/4" Bolt)	1
5	69209	(PHB) Crossmember (3/4" Bolt)	1
6	69239	(DS) Lower Bag Mount	1
7	69214	4.5" Lower Axle Clamp	2
8	69194	(PS) Frame/Bag Mount	1
9	69218	Fuel Tank Crossmember	1
10	17576	(PHB) 24 3/4" Centers 3/4" Bolt	1
11	18499	Trailing Arm Knuckle 10005	4
12	18498	Trailing Arm Knuckle 10006	4
13	10014	Bar - Trailing Arm	4

UNLESS OTHERWISE SPECIFIED: DIMENSIONS ARE IN INCHES TOLERANCES: FRACTIONAL ± 1/32" ANGULAR: MACH ± 1 BEND ± 1 TWO PLACE DECIMAL ±.030 THREE PLACE DECIMAL ±.010 MATERIAL: FINISH: WEIGHT:	Design By:	Zach Beltz 2014	Project:	2017 F450-550 Cab Chassis
	Shell # / Qty:		Description:	Stock Height 4-Link Rear
	Inventory:		SIZE	DWG. NO.
	Run Qty:		A	KLM-69210
PROPRIETARY AND CONFIDENTIAL THE INFORMATION CONTAINED IN THIS DRAWING IS THE SOLE PROPERTY OF KELDERMAN MFG. INC. ANY REPRODUCTION IN PART OR AS A WHOLE WITHOUT THE WRITTEN PERMISSION OF KELDERMAN MFG. INC. IS PROHIBITED.			SCALE:	1:20 DD NOT SCALE DRAWING SHEET 2 OF 7

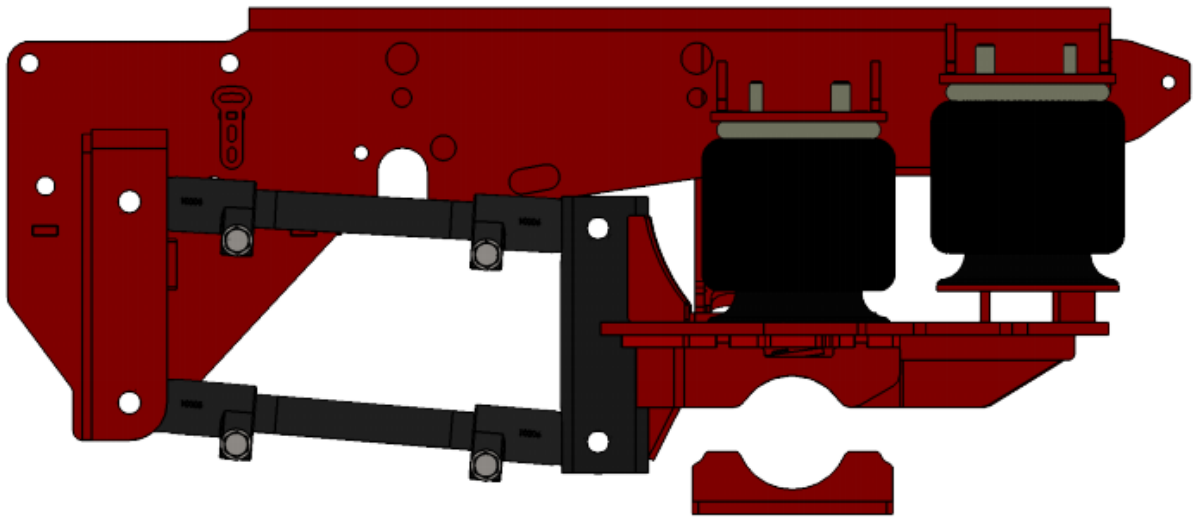

K
kelderman
AIR SUSPENSION SYSTEMS

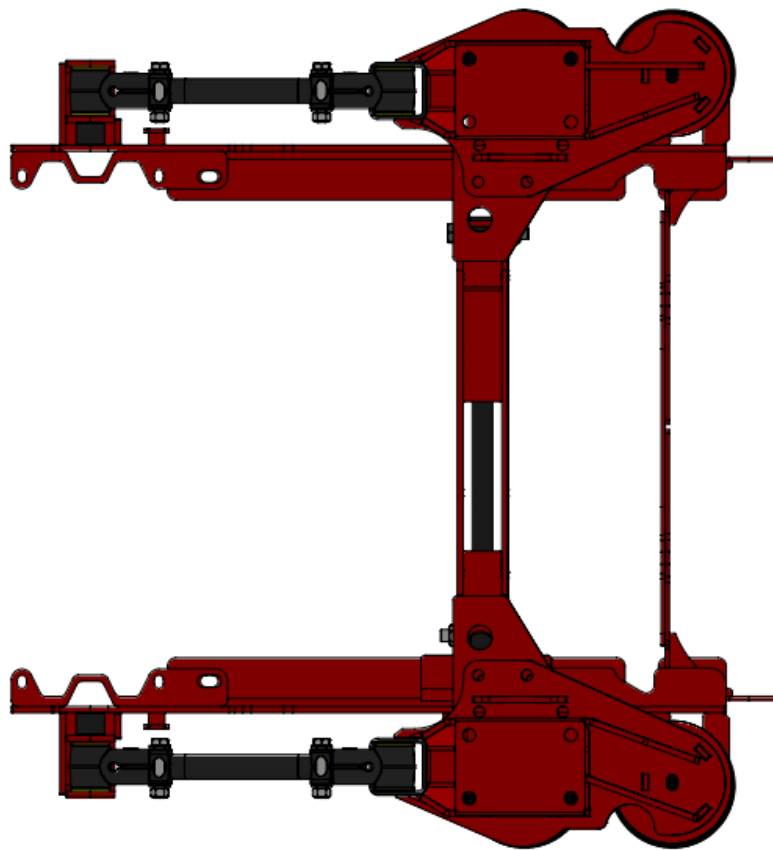

K
kelderman
AIR SUSPENSION SYSTEMS

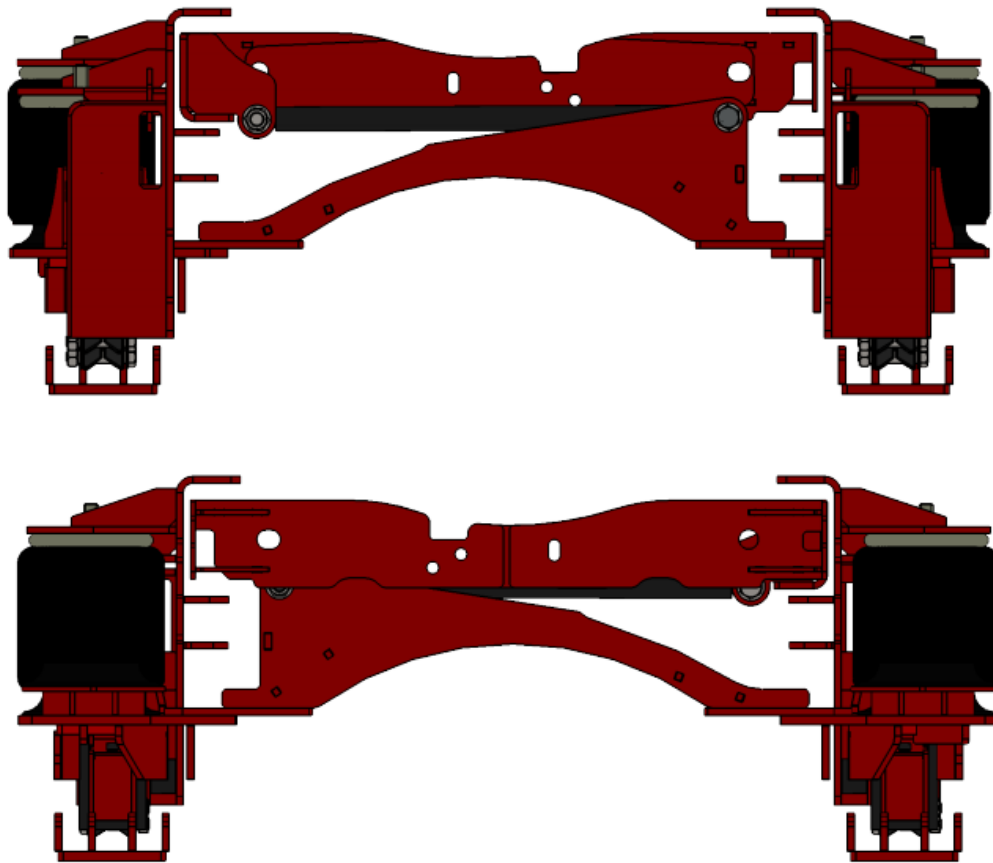

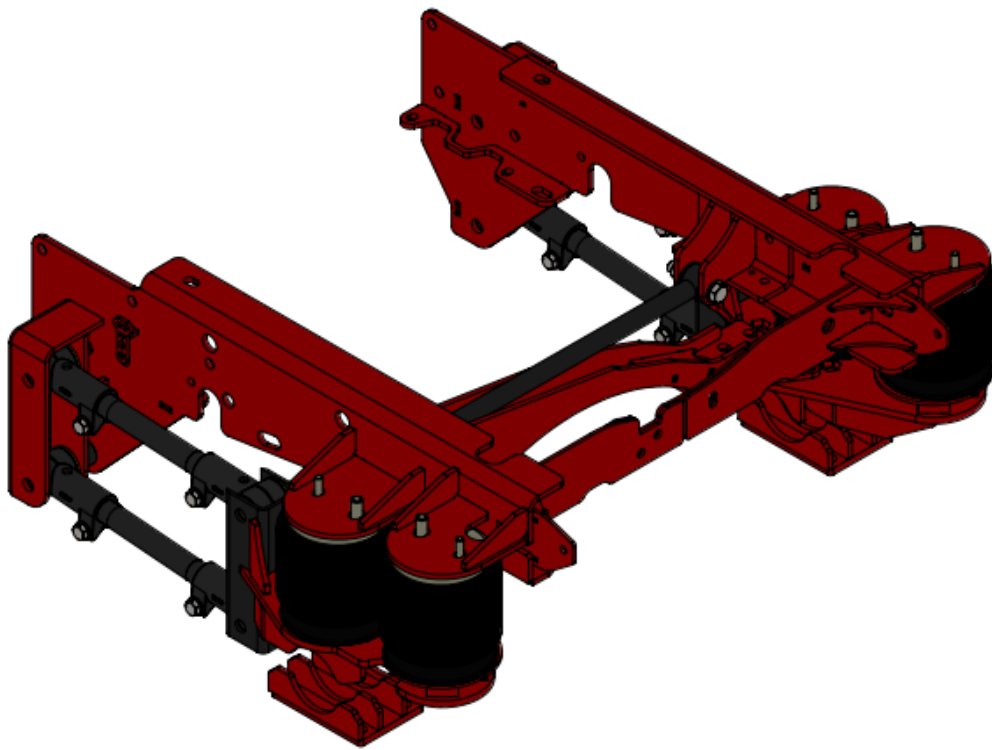

PRE-INSTALLATION CHECKLIST

- Check the vehicle wheel alignment prior to installation to insure no precondition already exists; record the information for verification.
- Measure and record the wheelbase and centering dimensions before beginning installation.
- Measure and record the height from the ground up to the rear of the frame.
- Measure and record the pinion angle. *See page 10 for specific instructions.*
- Remove the attached body, if applicable. Remember to disconnect all electrical connections and fuel filler tube, before removing the body. The installation can also be completed using a lift to raise the vehicle. If using a lift, chassis body removal may not be necessary but removal of rear wheels will aid in installation.
- If not using a lift, block the front wheels so the vehicle cannot roll.
- Jack up the rear frame of the truck in order to unload the rear leaf springs. Do not lift the wheels off the ground (if not using a lift to install the suspension). Do not jack on the axle itself.

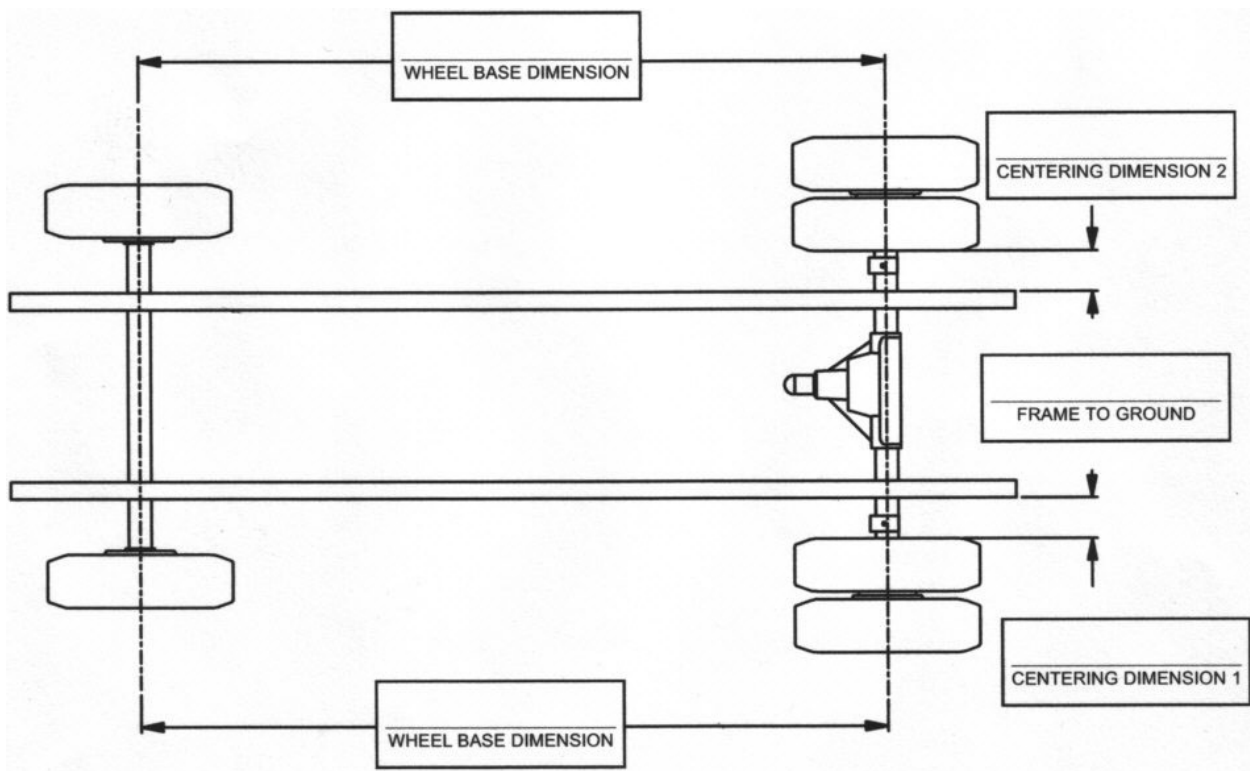

DETERMINING PINION ANGLE

The pinion angle is critical in the correct installation of your Kelderman Air Suspension System. The pinion angle can be easily determined with the use of a magnetic angle gauge.

To measure the angle, find a flat surface to attach angle gauge. Mark the location of your gauge with a marking pen or scribe. Record the angle on the gauge for future reference.

Note: It may be necessary to remove gauge. Marking the position of the gauge is critical to ensure accurate angle readings during adjustment steps of the assembly of your Kelderman Air Suspension System.

Pinion Angle: _____°

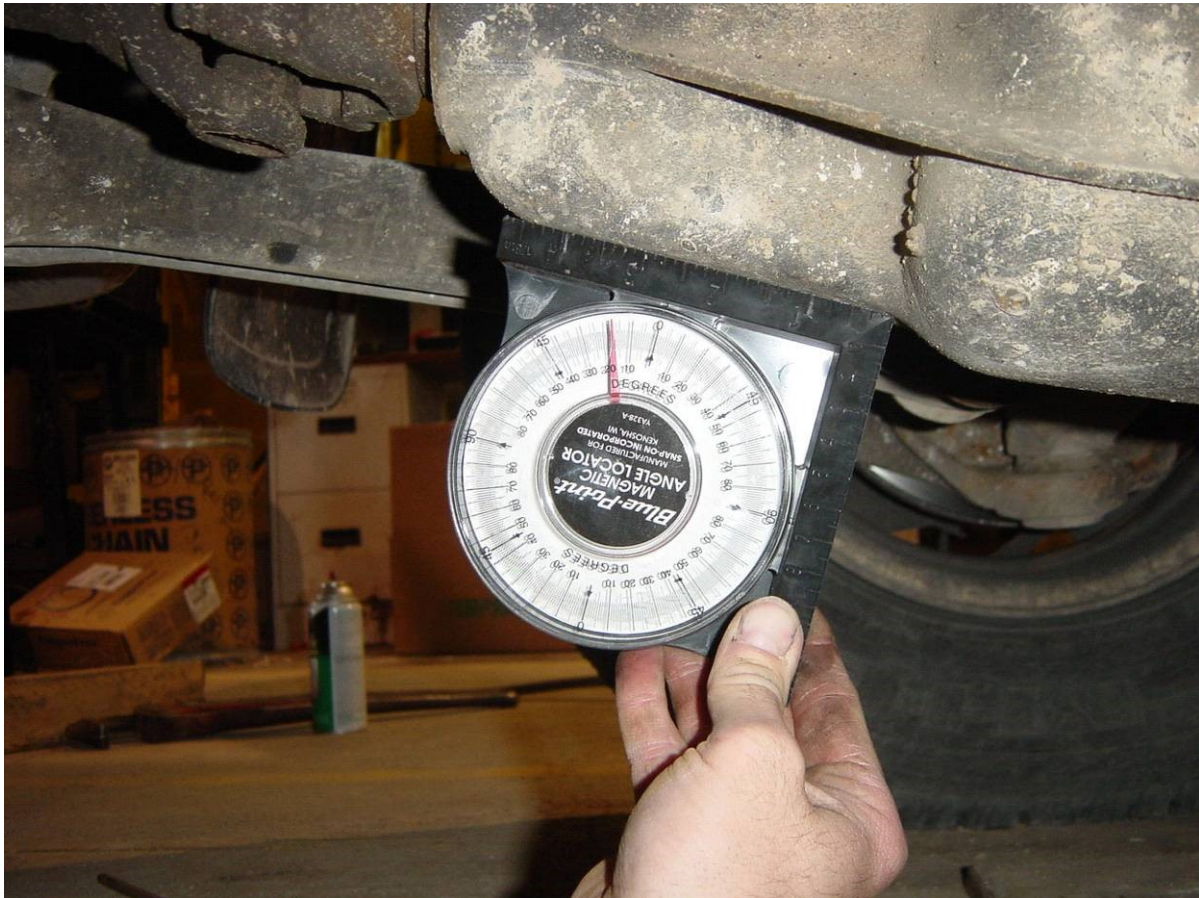

DISASSEMBLY

1. With weight taken off the rear springs, as noted in pre-installation checklist, remove the mount bolts from the front leaf spring hanger bracket. Remove the U-bolts that mount the spring to the axle. It works well to put a jack stand under the differential where the drive shaft connects to keep the axle from rolling down when the leaf springs are removed. Another option is to use a motorcycle strap to run under the yoke to keep the axle in place.

CAUTION: Be careful that the leaf spring does not spring out of its hanger, or off the frame.

Remove the bolt from the rear spring hanger. Remove the spring pack from the vehicle and discard. **DO NOT** re-use the fasteners that mount the bracket, or the leaf spring itself. New fasteners are provided, and must be used to achieve proper clamp load on the hanger.

2. Remove the rivets from the forward overload spring pads and discard.
3. Remove the jounce bumper and discard.
4. Remove the three E-Brake cable guides from the frame but **DO NOT DISCARD**. They will be re-used later in the installation. Disconnect the passenger side E-Brake cable at the point just forward of the driver side forward spring perch and remove it from its frame mount. You will have to route it through the Kelderman forward mounting bracket in a later step as shown in the photo below.
5. Remove Upper shock mount nuts and pull the upper shocks off their mounting studs to aid in assembly later in the instructions. Retain hardware for installation later.



ASSEMBLY

1. Locate the lower bag mounts (part # 69225 DS and 69239 PS), two air bags (part # 5323) and the eight 3/4" x 8 bolts. Insert the 3/4" bolts through the lower bag mounts locking the heads into the cutouts, then install the front air bags over the bolts using 1/2" x 4 1/2" bolts, flat and lock washers. Be sure to align the top of the air bag mounting studs so that the fill ports face to the center, and lay parallel to the frame. **Torque lower air bag bolts to 35 lb./ft.** Place these mounts over the axle leaf spring perch and lock in the dowel pin. Now fasten to the axle using the lower axle clamps (part # 69214), 3/4" flat washers and nuts. Do not torque the bolts (just snug) until the lower pan hard bar mount has been installed in step 3. You can then torque the 3/4" bolts to 175 lb./ft.





Just snug the axle clamps for now

K
kelderman
AIR SUSPENSION SYSTEMS

2. Locate the side plates (part# 69193 DS and 69194 PS) and the upper pan hard bar mount (part# 69208). The drivers side plates fasten to the side of the frame with the four 5/8 x 2, four 1/2 x 1 3/4" bolts and one 3/4 x 2" carriage bolts. (Do not put the nuts on the carriage bolts yet. The fuel tank crossmember reinforcement kit uses the 3/4" carriage bolt. Three of the 1/2 x 1 3/4" bolts fasten the side plate from the bottom of the frame and one goes in the side. The passenger side side plate utilizes the upper pan hard bar mounting on the inside of the frame. This requires four 17/32" holes to be drilled. Place the side plate over the passenger side frame rail and attach with the four 5/8x2" bolts and four 1/2x 1 3/4" bolts (three go in the bottom, one in the side of the frame. Place the pan hard bar mount on the inside of the frame rail. Use the small 3/8" hole in the bottom of frame flange where the bump stop originally was for a reference. You will need to drill the holes in the side of the frame and fasten the pan hard bar and side plate to the frame with the 1/2x2" bolts. Go ahead and torque these three bolts. Drill the two holes in the bottom of the frame. Fasten with the 1/2x2" bolts. Torque the 1/2" bolts to 85 ft./lbs. and the 5/8" bolts to 150 ft./lbs.

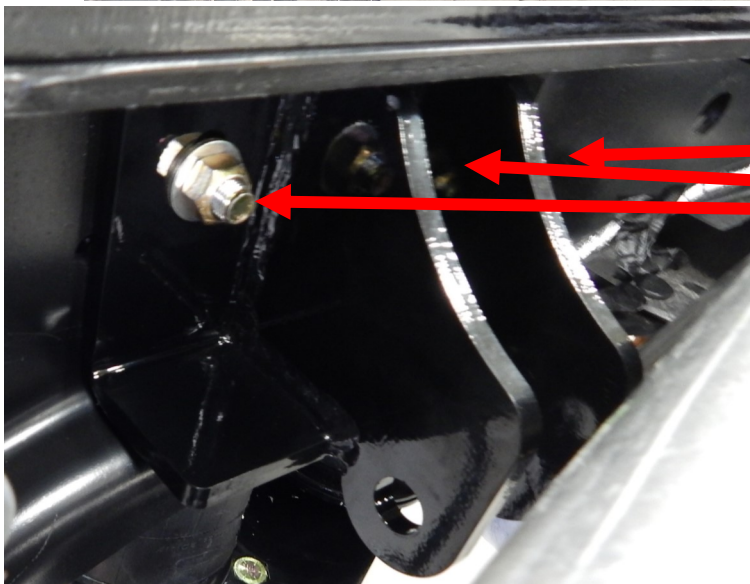

There are 3 holes in the side of the pan hard bar and two holes in the bottom that will be needed to be drilled in the frame. Use the 3 holes in the side plate for a drill jig and the 2 holes in the bottom of the pan hard bar for hole location

3. Locate the lower pan hard bar mount (part# 69209). The tall end goes towards the drivers side. It fastens to the lower air bag mounts with the 5/8 x 2" bolts and 1/2x8" U bolts. Torque the 5/8" bolts to 150 ft./lbs. and the 1/2" U bolts to 50 ft./lbs. Torque the 3/4" lower bag mounts to 175 ft./lbs.

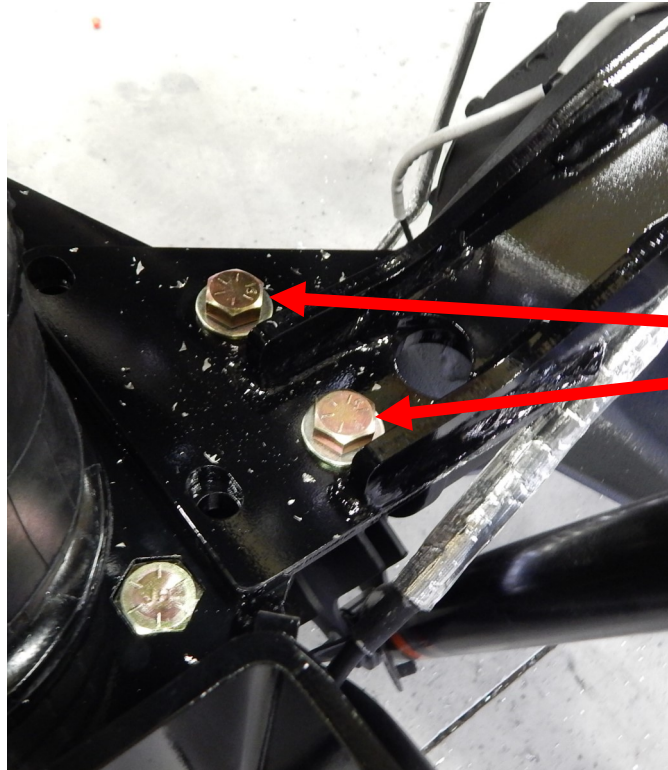

5/8 x 2" bolts

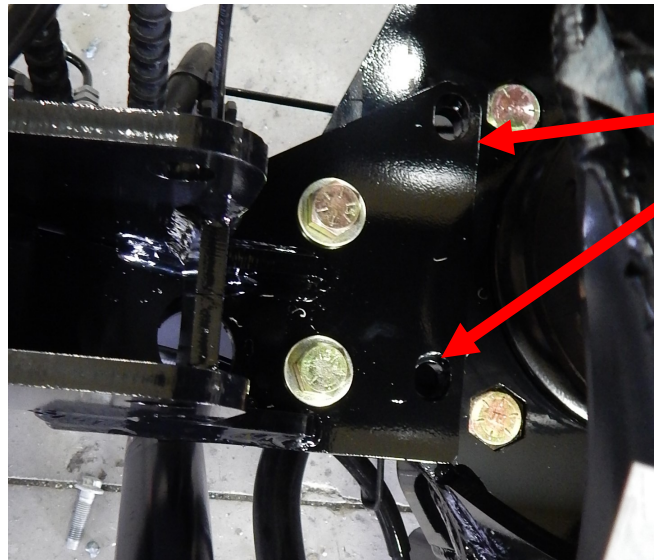

U bolts go in these holes



4. Locate two 5323 air bags. Fasten them to the rear of the lower air bag mounts with the $1/2 \times 5 \ 1/2$ " bolts. Make sure the top studs are in line with the upper air bag mounts. Torque the bolts and nuts to 35 ft./lbs.

5. Locate the four trailing arms. Adjust two of them so the distance is $8 \ 3/4$ " between the cast knuckles. These will be the top arms. Adjust the other two at $8 \ 1/2$ " between the cast knuckles. These will be used on the bottom.

The trailing arms fasten into the lower air bag mounts with the $7/8 \times 5$ " bolts. Insert these bolts so the head of the bolt is towards the frame and the nut is towards the tire. The top bar fastens into the side plate with the $7/8 \times 5 \ 1/2$ " bolt and the bottom bar fastens into the side plate with the $7/8 \times 7$ " bolt. Torque the $7/8$ " bolts to 275 ft./lbs.

Set the top arms at $7 \ 3/4$ " between knuckles and set the bottom arms at $7 \ 1/2$ ". *This will get the pinion angle close until the final adjustment stage.*

Nut faces the wheel on the rear trailing arms

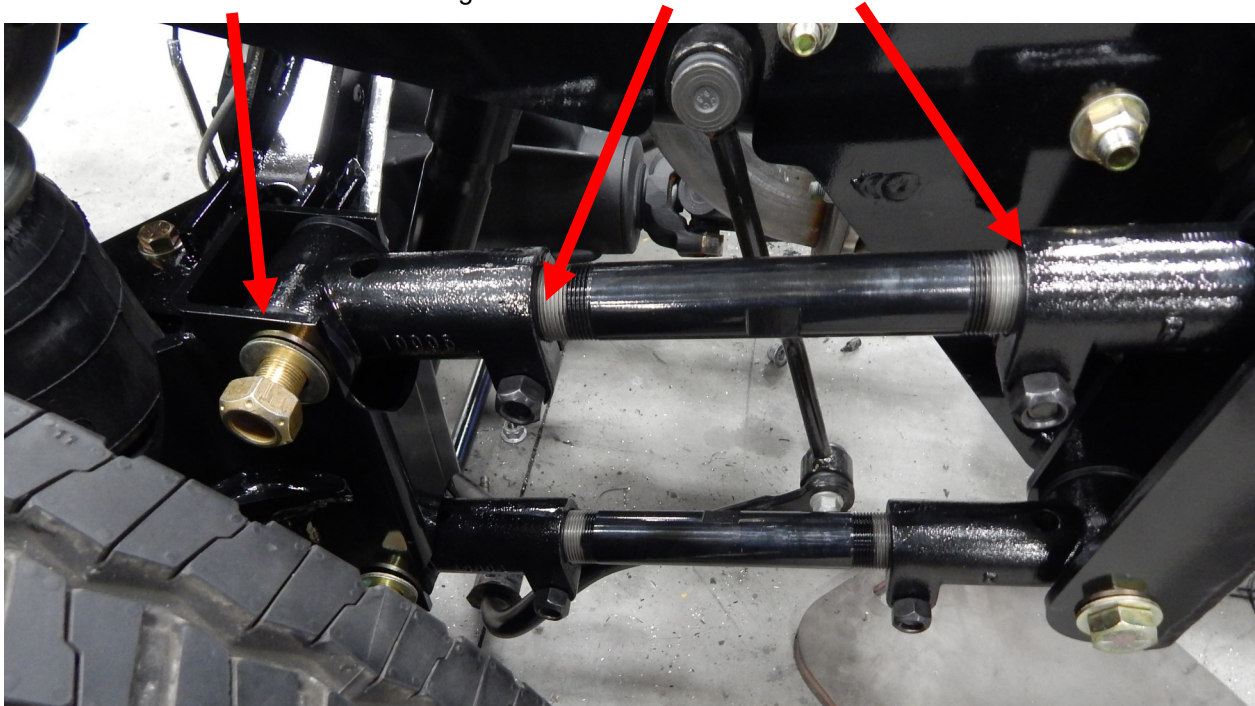

6. Locate the pan hard bar (part# 17576). It fastens into the upper pan hard bar mount with the 3/4 x 4" bolt. The other end fastens into the lower pan hard bar mount with the 3/4 x 1/2" bolts and has a spacer on each side. Torque these bolts to 85 ft./lbs.

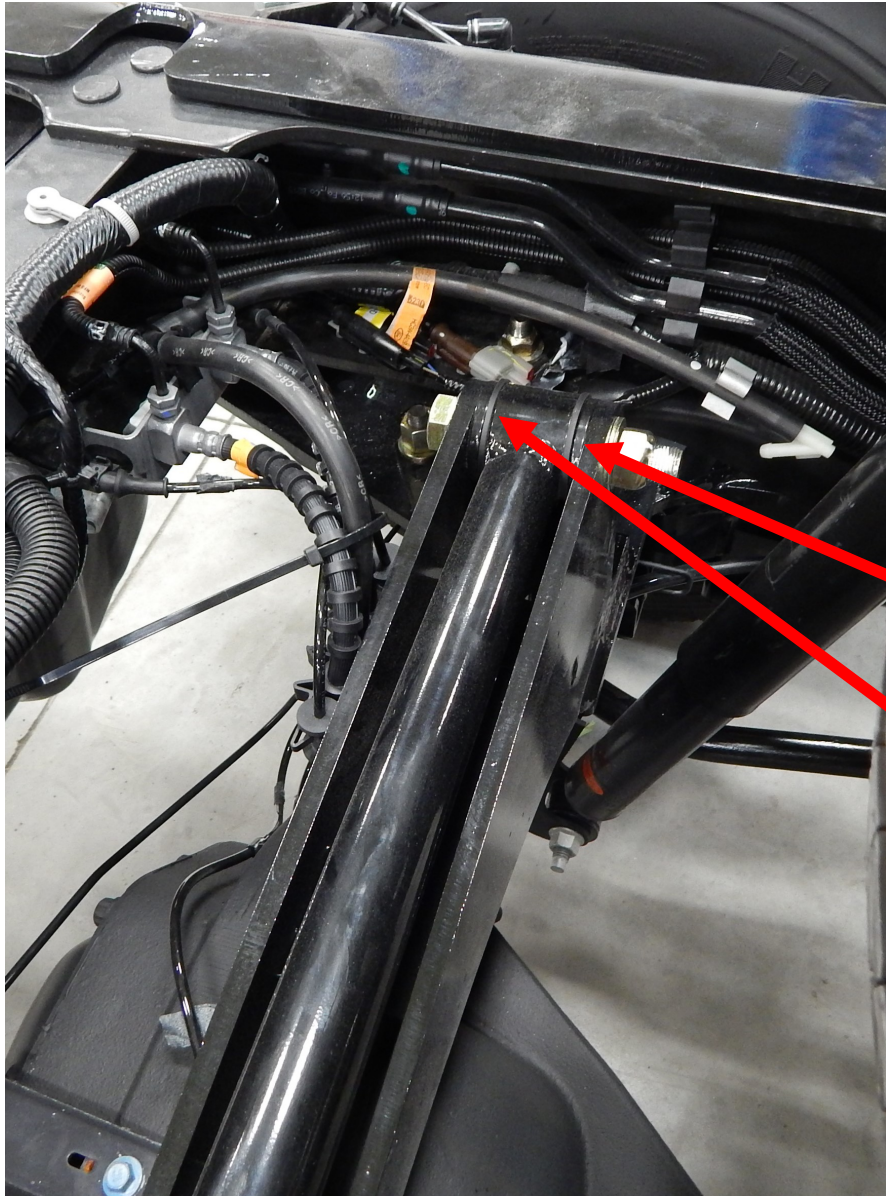

A spacer is placed on each side of the panhard bushing on the lower panhard bar mount





7. Locate the 3 piece fuel tank cross member kit (part #69218). The kit mounts inside the frame rails and across the back side of the factory cross member in front of the fuel tank. Place the single plate against the factory cross member. Place the right and left hand corner braces over the top of the flat plate. The center portion attaches to the fuel tank cross member with three 1/2x5" bolts and two 3/4 x 2" bolts. Left and right corner braces attach to the frame with the 3/4" carriage bolt and one 1/2 x 2" bolt. Torque the 1/2" bolts to 85 ft./lbs. and the 3/4" bolt to 135 ft./lbs.



Crossmember kit installed

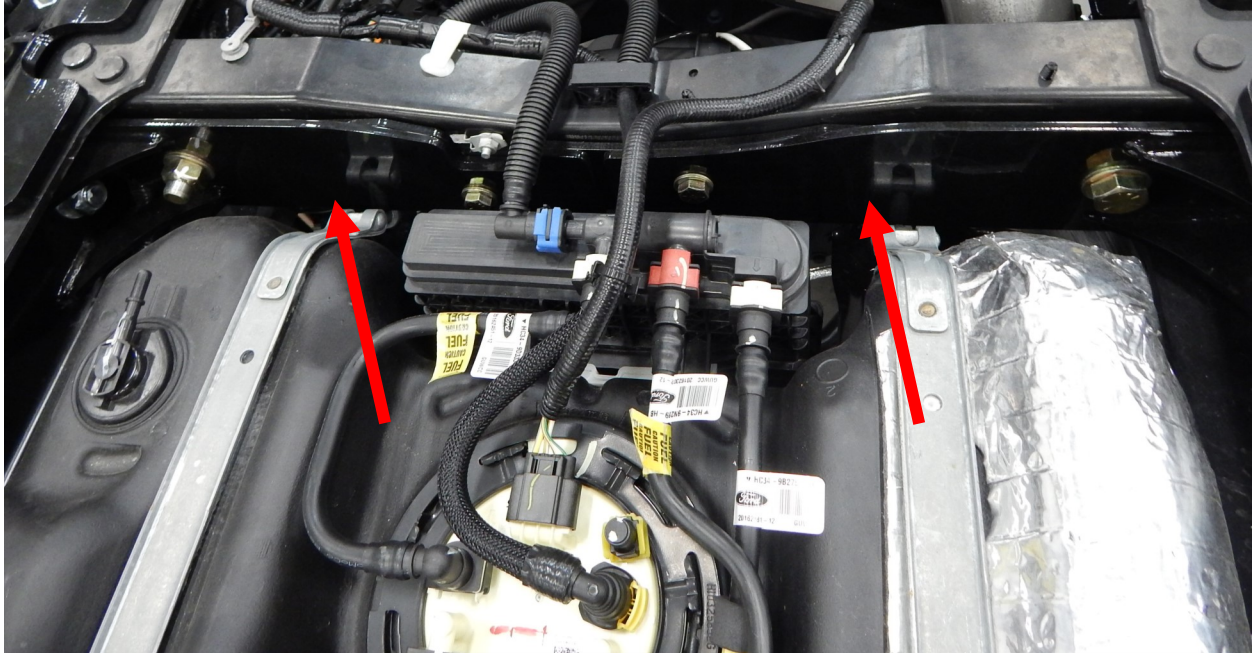

8. Locate the rear sway bar (part# 1139-190KLD). It fastens to the original OEM mounts with the factory bolts and d ring. Use the new bushings provided. Use Loctite on the factory bolts and torque to 55 ft./lbs.

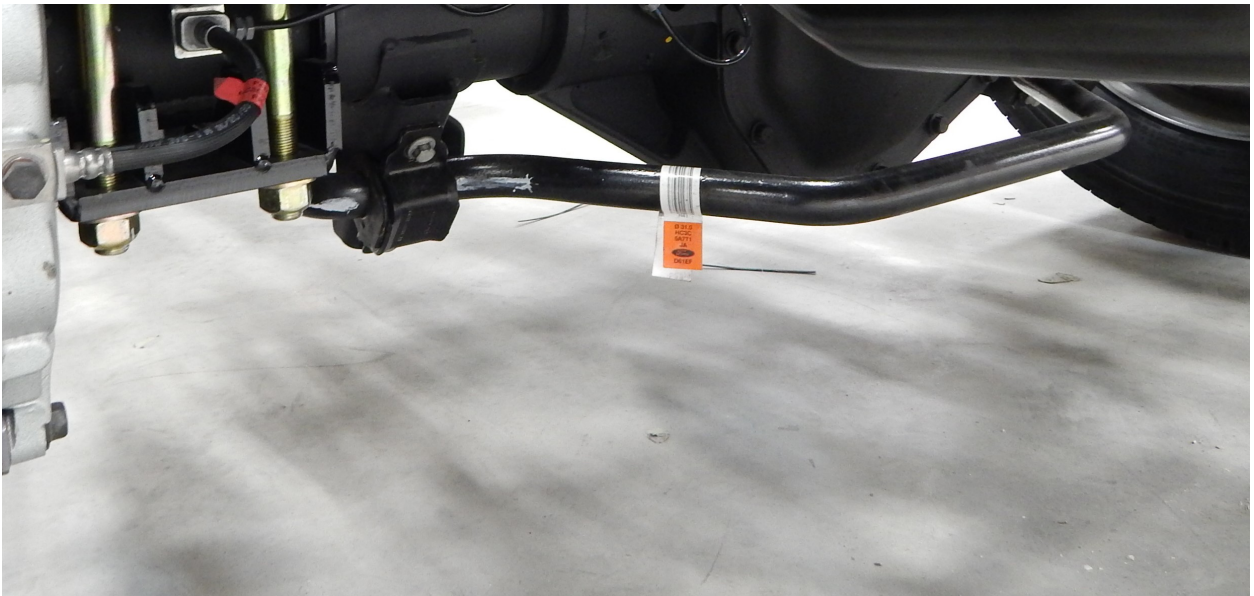

MECHANICAL AIR CONTROL SYSTEM (optional)

1. Plumbing of the system. Insert the fittings in the top of the four air bags. Locate the Haldex height control valve and use the 1/4" x 1 1/4" bolts to fasten the height control valve to the front trailing arm bracket on the driver's side. Mount the ball to the end of the height control valve, fasten the lock collar to the lower control arm and connect the linkage between them.
2. Locate the compressor box. Mount the box somewhere on the frame, preferably on the driver's side frame rail. Use the wiring diagram provided at the end of the instruction packet to wire up the system. Also provided is an air line diagram. If the vehicle has tool boxes it works well to put the compressor box in there. The plastic cover can be removed if its in an enclosure.
3. Locate the air tank. Find an area on the frame to mount it. Make sure the drain plug is facing straight down.
4. Once you have the compressor wired up, the air line going to the air tank, run an air line from the air tank to the bottom port of the height control valve. Locate the clear line and plastic fitting supplied with the height control valve and install it in the top port. This is the exhaust. Next locate the three brass "T" fittings. Connect the two air bags on each side with a "T" fitting. Next, connect the right side and left sides together with another "T" fitting. Connect this "T" fitting to the CYL port on the dump valve. Last, connect an air line from supply port to middle port on the height control valve.

The height control valve mounts to the side plate with the 1/4 x 1" bolts.

The collar fastens to the top trailing arm just where the threads start

The linkage clips on the ball studs on valve arm and collar

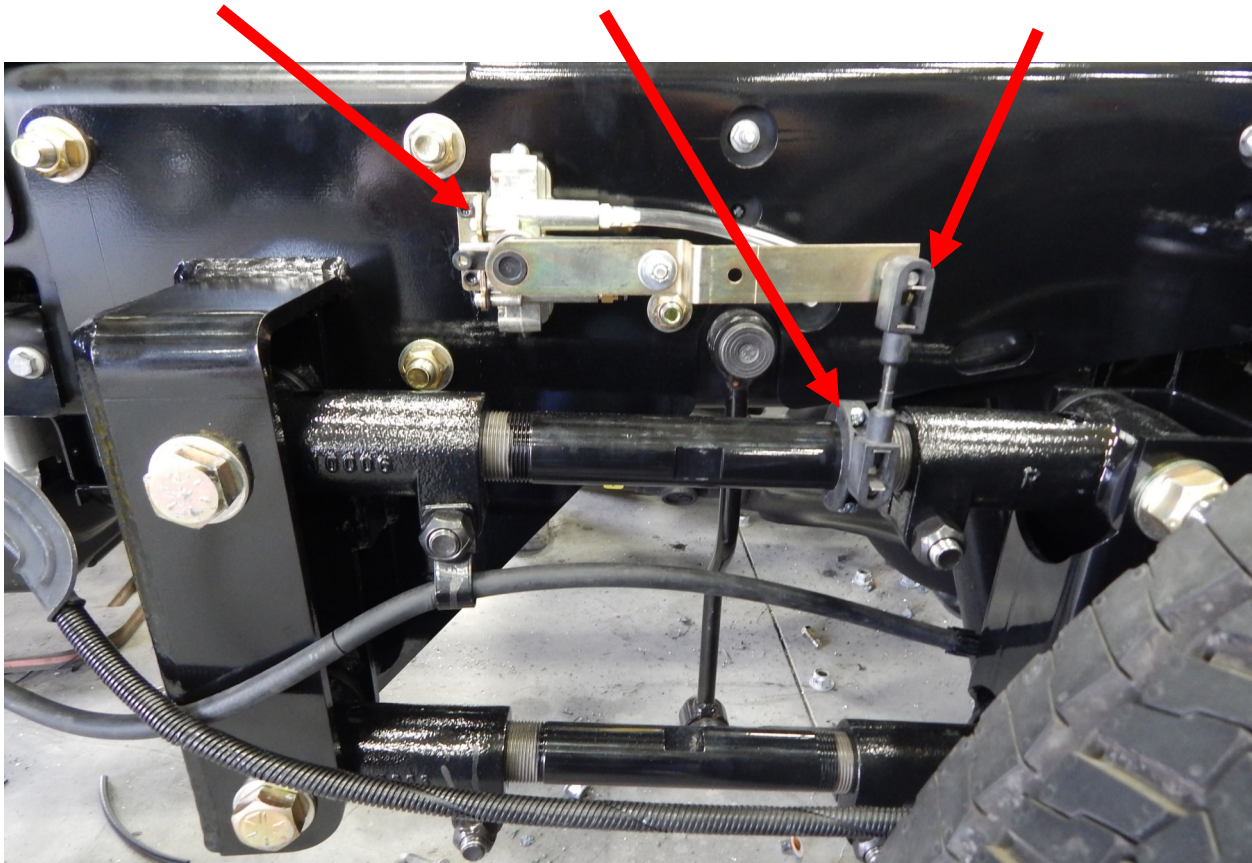



Hadley height control sensor pictured (2016 F-450)

****NOTE:** Once the system is wired up and plumbed, turn on the ignition and the compressor will start running. Upon first start up when there is no air in the tank, it will take around 6-8 minutes until the system is charged, air bags filled. After the compressor shuts off, check for leaks. It works best to use soapy water or gas leak detector sold at hardware stores. Check all the fittings and connections in the entire system.

FINAL INSPECTION CHECKLIST

1. Air System Start Up and Check - remove all jacks, and air the system up by either using the fill valve on the air tank or by starting the vehicle and switching the compressor switch to "ON". Note: the maximum allowable pressure in the air tank is 175 psi. It is recommended to fill the air tank using the supplied Schrader valve so that the compressors are not taxed too much by running for a long period of time.
2. Height Control Valve Operation Check - with one end of the valve linkage disconnected, rotate the valve arm down 45°, air should exhaust from the air bag. Rotating the valve arm up 45° should cause the valve to fill the air bag.
3. Measure & Record the "Ride Height" of the air bag - measure ride height of the air bag from upper air bag mount to lower air bag mount (see picture below). The kit is designed to ride at 8". To adjust the ride height, complete the following steps (see picture on next page). Loosen upper height control valve bolt. Rotating height control valve body toward rear of chassis this will increase the ride height. Rotating height control valve body toward front of chassis will decrease ride height. Tighten upper height control valve bolt. Once the ride height is set, reconnect the linkages. Jostle the suspension up and down and allow it to come back to ride height. Recheck the initial measurement and adjust if needed.
4. Bushing Bolts Final Torque - with the suspension at ride height, torque all bushing fasteners. This will include all fasteners for the Control Arm and Pan Hard Bar. (Refer to *Torque* table for specific torques).
5. Reinstall shocks and mounting nuts.
6. Move the suspension through its entire range of motion by inflating and deflating the air bags to achieve full travel. Check for any interference with the pan hard bar, axle, shocks, exhaust, frame, brake lines, fuel lines, etc. Reconnect valve linkage to trailing arm.
7. Recheck all fasteners for specified torque.
8. Double check all electrical connections and wire routings.
9. **IMPORTANT!** Check all fittings and air lines for air leaks.
10. Measure and record wheelbase and centering dims on final dimension sheet.
11. Reinstall the chassis body (if applicable).

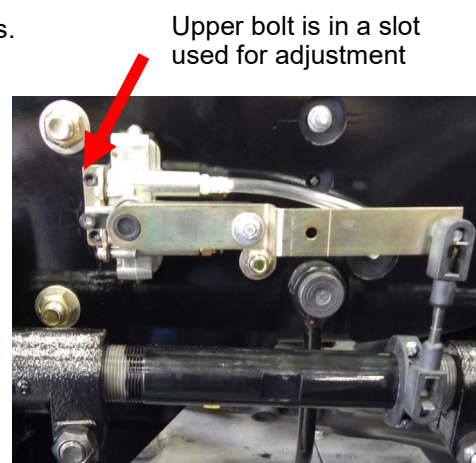

OPERATION GUIDELINES

1. After all final checks are complete, it is recommended to perform a road test. If vehicle pulls to the left or right, or any driveline vibration occurs, return and recheck wheelbase measurements and driveline angles. **Note:** improper driveline angles may have a detrimental affect on ride, U-joints, and transmission.
2. **Kneeling Operation:** Moving the dump switch to "ON" position will exhaust all air from the air bags and lower the rear of the vehicle approximately 3-4 inches. Air bags will inflate when the switch is returned to the "OFF" position. **WARNING: Do not drive the vehicle while the Dump Switch is on and the air bags are deflated.**
3. **IMPORTANT!** During servicing check tightness of all fasteners and for any air systems leaks.
4. **IMPORTANT!** Immediate corrective action should be taken if malfunctions occur.
5. **Air Bag Ride Height Setting Procedure for Systems with Dual Height Control Valves**
 1. Deflate the passenger side air bag by disconnecting the linkage from the arm.
 2. With the driver side linkage connected, measure the ride height and adjust accordingly by the methods mentioned above.
 3. Once the ride height is set for the driver side, repeat the same steps for the passenger side, including deflating the driver side air bag.
 4. Once the ride height is set, reconnect the linkages.
 5. Jostle the suspension up and down (or take the vehicle on a short drive) and allow it to come back to ride height. Recheck the initial measurement and adjust if needed.

Note: this procedure to set ride height can be done when empty or under light load.

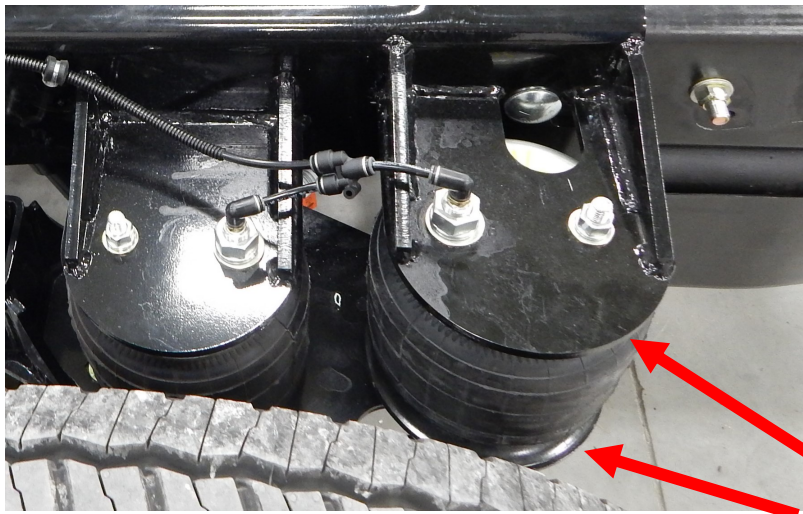

Set the air bags so there is 8" between the mounting brackets that hold the air bags in place

SERVICE & MAINTENANCE

The Kelderman suspension needs no lubrication and little maintenance. The following components should be checked at the same time the chassis is being serviced. However, immediate corrective action should be taken if a serious malfunction occurs. See Exploded Assembly on page 18 for details.

Caution! If maintenance or service is to be done on the air system, be sure to drain **ALL** air from system. Serious injury could occur if components are removed while system is full of air.

Note: It is important to release any moisture contained within the air reservoir on a daily basis. Not releasing the moisture on a regular basis will cause the drain valve to not operate properly, and may cause the valve to malfunction. Excess moisture in the system can also cause premature failure of other components including the tank itself.

AIR BAG SERVICE

The forward air bag can be serviced without removing the axle brackets from the axle. Detach the upper air bag mounting studs from the upper bag plate. Utilizing a modified 3/4" wrench, the forward air bag lower mounting bolt can be loosened. Rotate the air bag counter-clockwise off the lower mounting bolt to remove air bag. To install, reverse the process.

SERVICE & MAINTENANCE CHECKLIST

1. Check and document rear axle alignment.
2. Verify ride height at 8" between upper and lower air bag mounting plates.
3. Verify suspension function via dump and re-inflation.
4. Check for air leaks and system integrity.
5. Check clearances throughout suspension motion range.
6. Check driveline angle.
7. Check 4 wheel alignment.

TORQUE TABLE

Location	Fastener	Torque
Front trailing arm mounts	1/2" UNF Nuts	85 LB/FT
Front trailing arm mounts	5/8" UNF Nuts	150 LB/FT
Lower bag mounts	3/4" UNF Nuts	175 LB/FT
Upper bag mounts	1/2" UNF Nuts	85 LB/FT
Upper bag mounts	5/8" UNF Nuts	150 LB/FT
Air bags	1/2" UNC Nuts	35 LB/FT
Air bags	1/2" UNC Bolts	35 LB/FT
Air bags	3/4" UNF Nuts	35 LB/FT
Pan hard bar	5/8" UNF Nuts	75 LB/FT
Pan hard bar mount	1/2" UNF Nuts	85 LB/FT
Trailing arms (pinch bolts)	5/8" UNC Nuts	150 LB/FT
Trailing arms	7/8" UNC Nuts	275 LB/FT
D bushing for sway bar	12mm bolts	75 LB/FT
Pan hard bar mount	1/2" UNF Nuts	85 LB/FT
Pan hard bar mount	5/8" UNF Nuts	150 LB/FT

FINAL DIMENSION SHEET

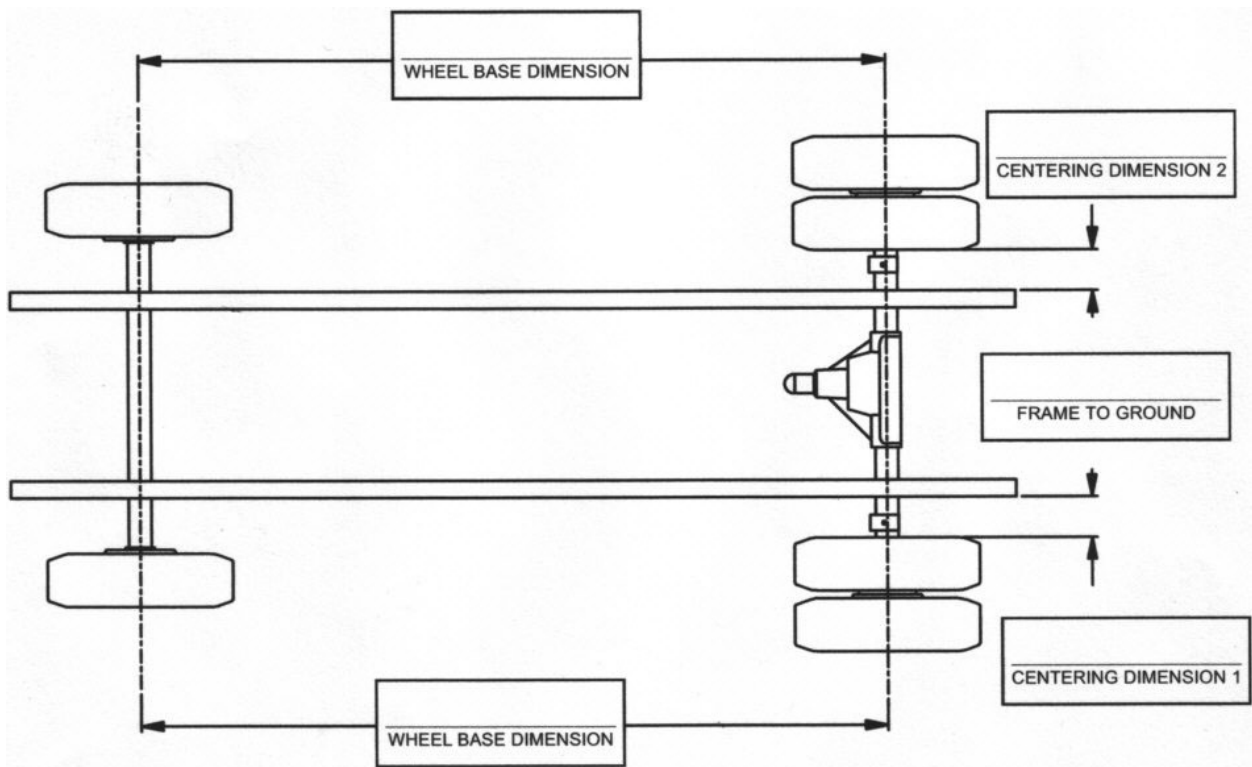

FORD F450/550 OWNERS GUIDELINES

The Kelderman suspension needs no lubrication and little maintenance. However, immediate corrective action should be taken if a serious malfunction occurs.

CAUTION! If maintenance or service is to be done on the air system, be sure to drain all air from the system. Serious injury could occur if components are removed while system is full of air.

PRODUCT OWNER RESPONSIBILITIES

- Owner is solely responsible for pre-operation inspection, periodic inspections, maintenance, and use of the product as specified in the particular Kelderman MFG. instructions available by product model, except as provided in this warranty, and for maintenance of other vehicle components. Of particular importance is the re-torque of fasteners including axle bolts, four link bolts, and pan hard bar bolts. This re-torque must be performed within 90 days of the suspension being put into service.
- Owner is responsible for “down time” expenses, cargo damage, and all business costs and losses resulting from a warrantable failure.
- The Kelderman Air Suspension is fully automatic in controlling the height of the chassis when properly installed. No manual intervention to control air pressure or ride height is needed during the course of operation.
- The Compressor Switch must be on for the compressor to operate. During difficult starting circumstances, (i.e. extremely cold weather) it is recommended to turn the compressor switch off until the vehicle is running, so it will not draw current from the battery. The compressor is controlled by the pressure switch located in the Air Control Box. This switch automatically turns the compressor on when the tank pressure falls below 110 psi, and turns them off at 145 psi.
- The Low Pressure Warning Light indicates a severe drop in tank pressure (below 45 psi). Immediate corrective action should be taken to determine the cause of air loss. Compressor switch should be turned off if Low Pressure Warning Light is on, and remains on even after the compressor has run for a normal period of time. **NOTE:** The Low Pressure Warning Light could come on briefly when the “Dump” feature is being used.
- When the weather is below freezing, it is important to release any moisture contained within the air tank on a daily basis. This is done by pulling on the attached release cable for approximately 5 seconds or turning the petcock. Not releasing the moisture on a regular basis will cause the drain valve to not operate properly.

CHECK AT EVERY VEHICLE SERVICE INTERVAL:

- Check Ride Height $\pm 1/4$ "
- Check for air leaks around fittings.

CHECK AFTER THE FIRST 1000 MILES:

- Recheck & tighten any loose fasteners.
- Check for any loose or worn components.

CHECK AFTER EVERY 30,000 MILES:

- Check trailing arm bushings and pan hard bar bushings for wear; replace if worn.

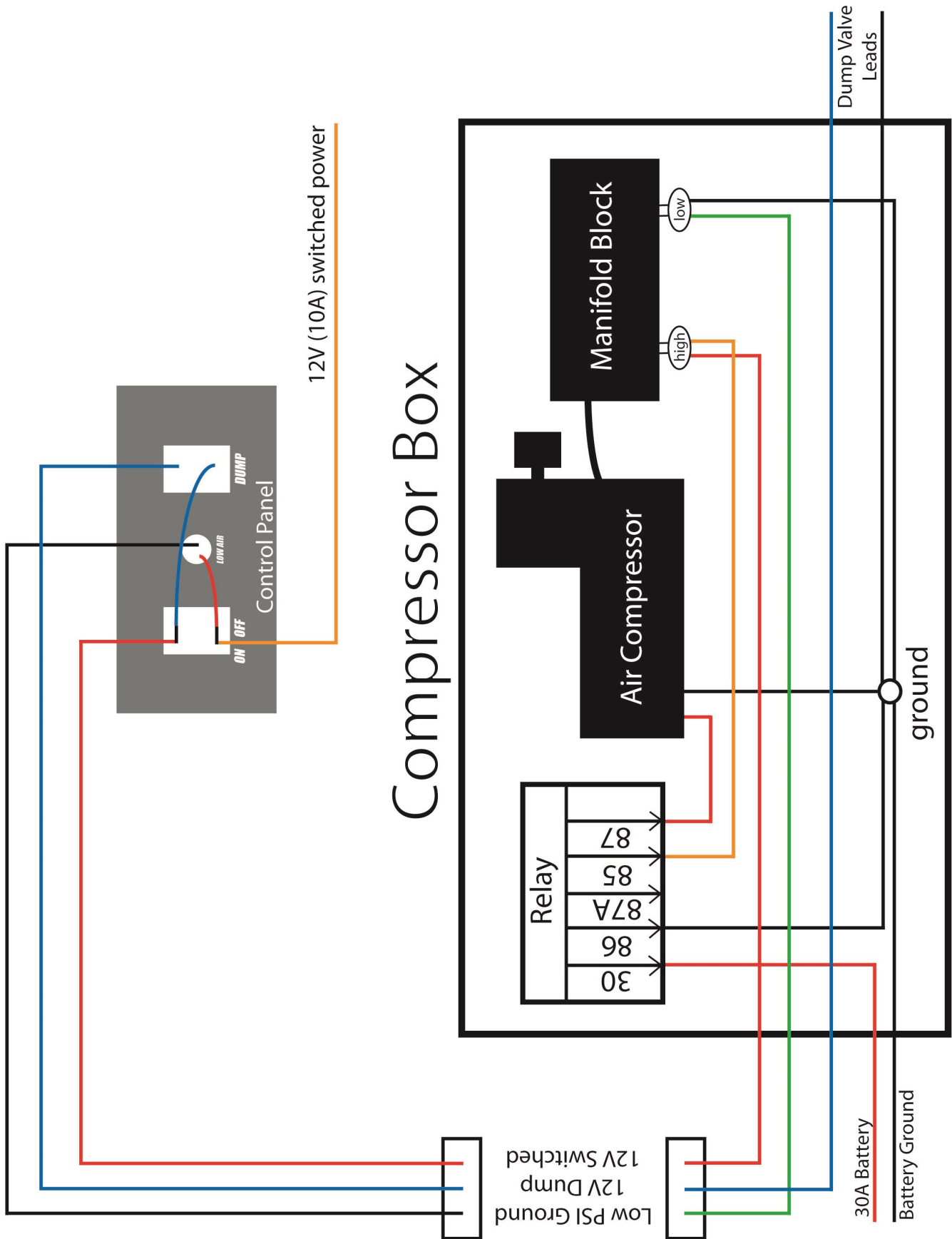

Compressor Box Self-Leveling Kit Wiring Diagram (shown with optional dump valve)

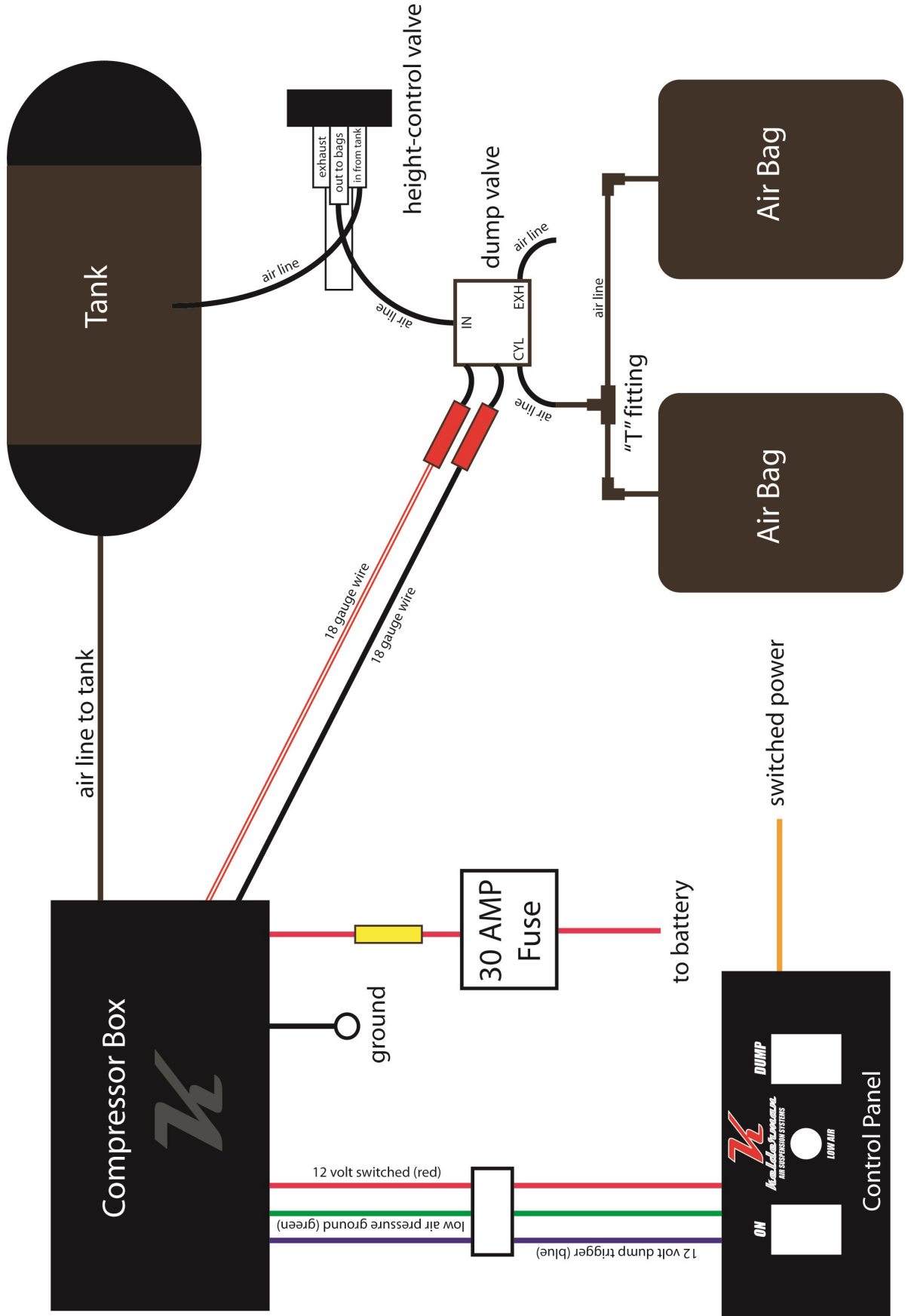

TROUBLE SHOOTING GUIDE

<u>COMPONENT</u>	<u>POSSIBLE PROBLEM</u>	<u>CORRECTIVE ACTION</u>
Air lines	Air leaks	Replace air line.
Fittings	Air leaks	Remove fitting and apply fresh joint compound. Reinstall fitting, but Do Not Over Tighten. Do not use Teflon tape.
Air Bags	A. Improper height B. Air leakage	A. Adjust valve linkage to maintain proper air spring height. B. Replace air bag.
Panhard Bar	A. Loose nuts on lateral control rod bolts. B. Worn bushings	A. Tighten securely. B. Replace lateral control rod.



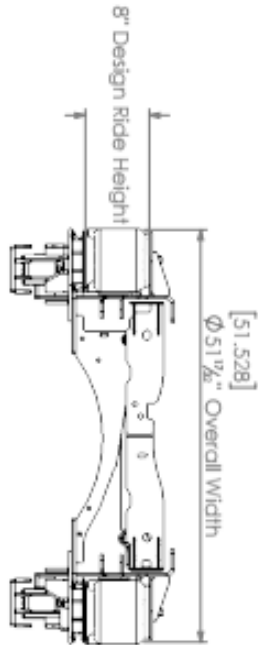
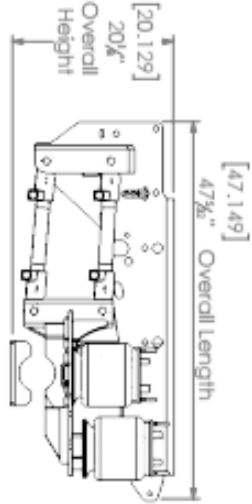
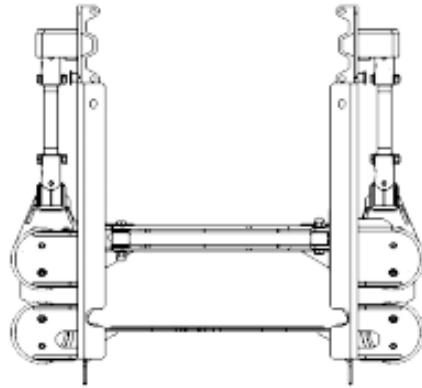

UNLESS OTHERWISE SPECIFIED: DIMENSIONS ARE IN INCHES TOLERANCES: FRACTIONAL: 1/32"		Design By: Zach Beltz 2014		Project: 2017 F450-550 Cab Chassis	
ANGULAR: MDC: 1 BAND: 1		Shell # / Qty		Description: Shock Height 4-Link Rear	
TWO PLACE DECIMAL: 5.00		Inventory		SIZE DWG. NO.	
THREE PLACE DECIMAL: 1.00		Run Qty:		A KIM-69210	
MATERIAL		PROPRIETARY AND CONFIDENTIAL THE INFORMATION CONTAINED IN THIS DRAWING IS THE SOLE PROPERTY OF KELDERSMAN MFG. INC. ANY REPRODUCTION IN PART OR AS A WHOLE WITHOUT THE WRITTEN PERMISSION OF KELDERSMAN MFG. INC. IS PROHIBITED.			
FINISH					
WEIGHT SMA.30		SCALE: 1:20		DO NOT SCALE DRAWING	
				SHEET 3 OF 7	