

ITEM NO.	PART NUMBER	DESCRIPTION	QTY.
1	15636	Weldment - Top Frame	1
2	15617	Weldment - Swing Arm	1
3	80012-5323	Firestone 5323	2

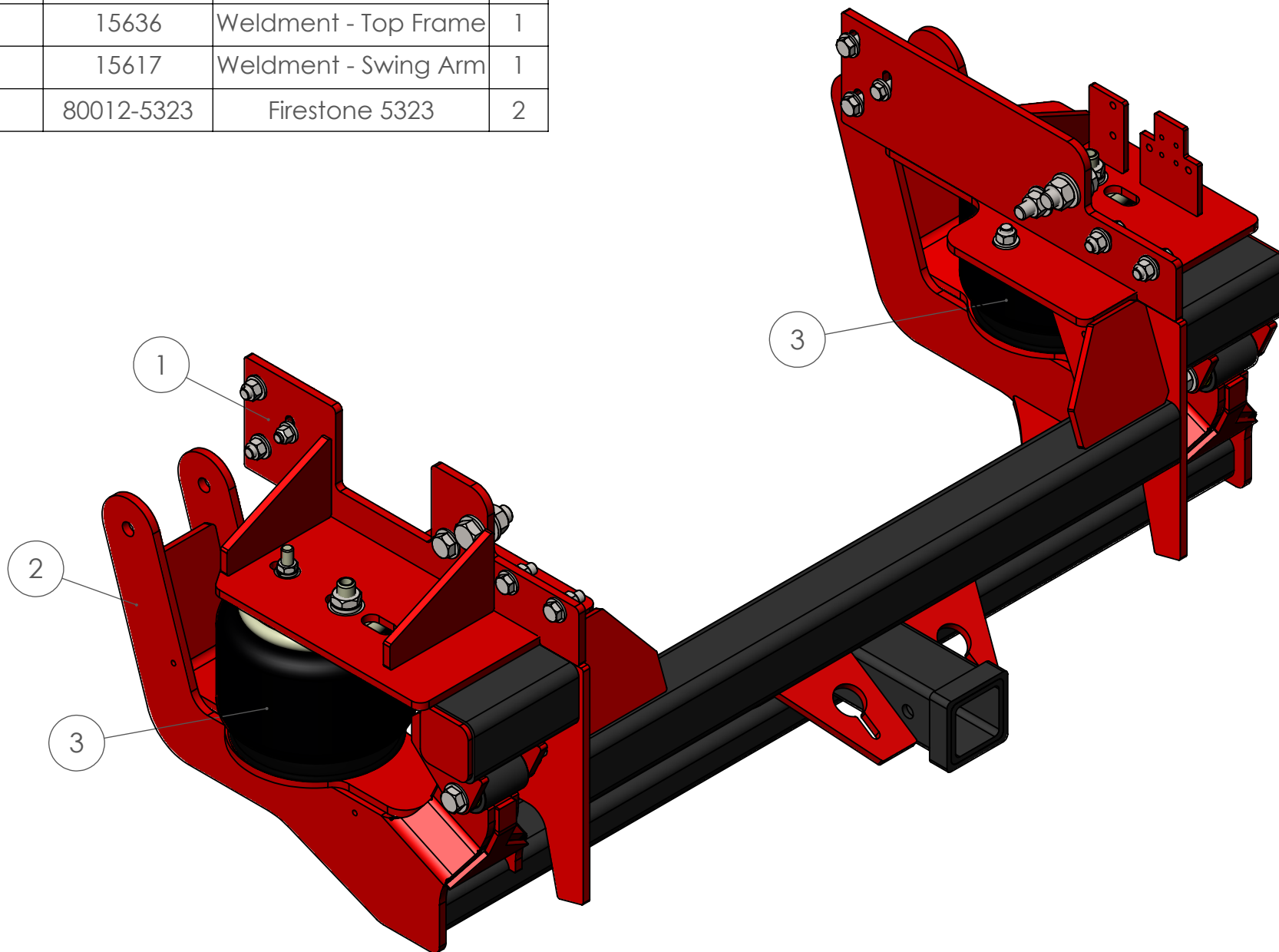

					 3RD ANGLE PROJECTION	A DO NOT SCALE DRAWING 1:20 Approximate Weight = 230.21 lbs
					UNLESS OTHERWISE SPEC. DIMENS. IN INCHES STD. TOLERANCES X.X ± 0.60 X.XXX ± 0.030 X.XXXX ± 0.010 FRAC. DIM. ± 1/32" Deg. ± .5°	MATL SPECS: SEE ABOVE DESCRIPTION: Kelderman 2-Bag Rear PROJECT: 2007+ Dodge 3500 Chassis Cab 2-Stage (Rear) PART NUMBER: KLM-15629
REV	ECN	CHANGE DESCRIPTION	CHANGE BY	DATE	DESIGN BY: ZB18	DATE: 10/10/2018 NOTICE: THIS DOCUMENT AND ITS CONTENTS ARE THE PROPERTY OF KELDERMAN MFG. NO USE OR COPIES MAY BE MADE WITHOUT WRITTEN PERMISSION FROM KELDERMAN

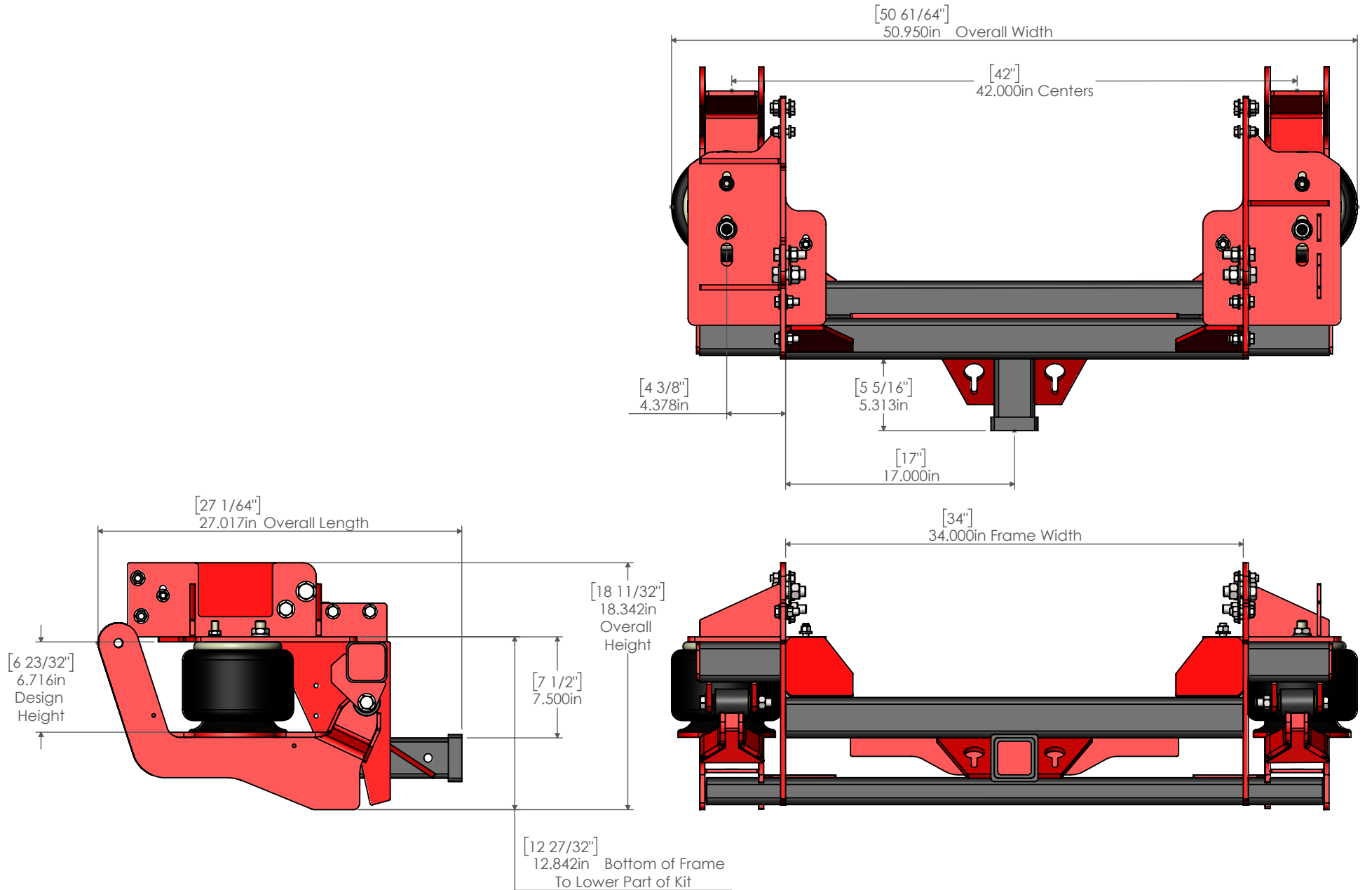



						 3RD ANGLE PROJECTION	A DO NOT SCALE DRAWING 1:20 Approximate Weight = 230.21 lbs
						UNLESS OTHERWISE SPEC. DIMINS. IN INCHES STD. TOLERANCES X.X ± 0.60 X.XX ± 0.30 X.XXX ± 0.10 FRAC. DIM. ± 1/32" Deg. ± .5°	MATL SPECS: SEE ABOVE DESCRIPTION: Kelderman 2-Bag Rear PROJECT: 2007+ Dodge 3500 Chassis Cab 2-Stage (Rear)
							PART NUMBER: KLM-15629 DESIGN BY: ZB18 DATE: 10/10/2018
REV	ECN	CHANGE DESCRIPTION	CHANGE BY	DATE			NOTICE: THIS DOCUMENT AND ITS CONTENTS ARE THE PROPERTY OF KELDERMAN MFG. NO USE OR COPIES MAY BE MADE WITHOUT WRITTEN PERMISSION FROM KELDERMAN.

