

ITEM NO.	PART NUMBER	DESCRIPTION	No Frame/QTY.
1	10000	(PS) Bag Mount / Duel Shock	1
2	10565	Crossmember - 31" Center to Center	1
3	11107	TRAILING ARM - 28.50	2
4	11108	43" Trailing Arm	2
5	16442	(PS) Sway Bar Drop Bracket	1
6	16443	(DS) Sway Bar Drop Bracket	1
7	18086	Transfer Case Crossmember 25°	1
8	18091	25° Mounting Bracket	1
9	20127	(DS) Lower Bag Mount	1
10	20131	(PS) Front Side Plate	1
11	20132	(DS) Front Side Plate	1
12	20158	(DS) Bag Mount / Duel Shock	1
13	20160	(PS) Lower Bag Mount	1
14	30551	Panhard Bar Drop Bracket	1
15	16429	Steering Stabilizer F250/350 Assembly	1
16	5323-1	Firestone 5323	2

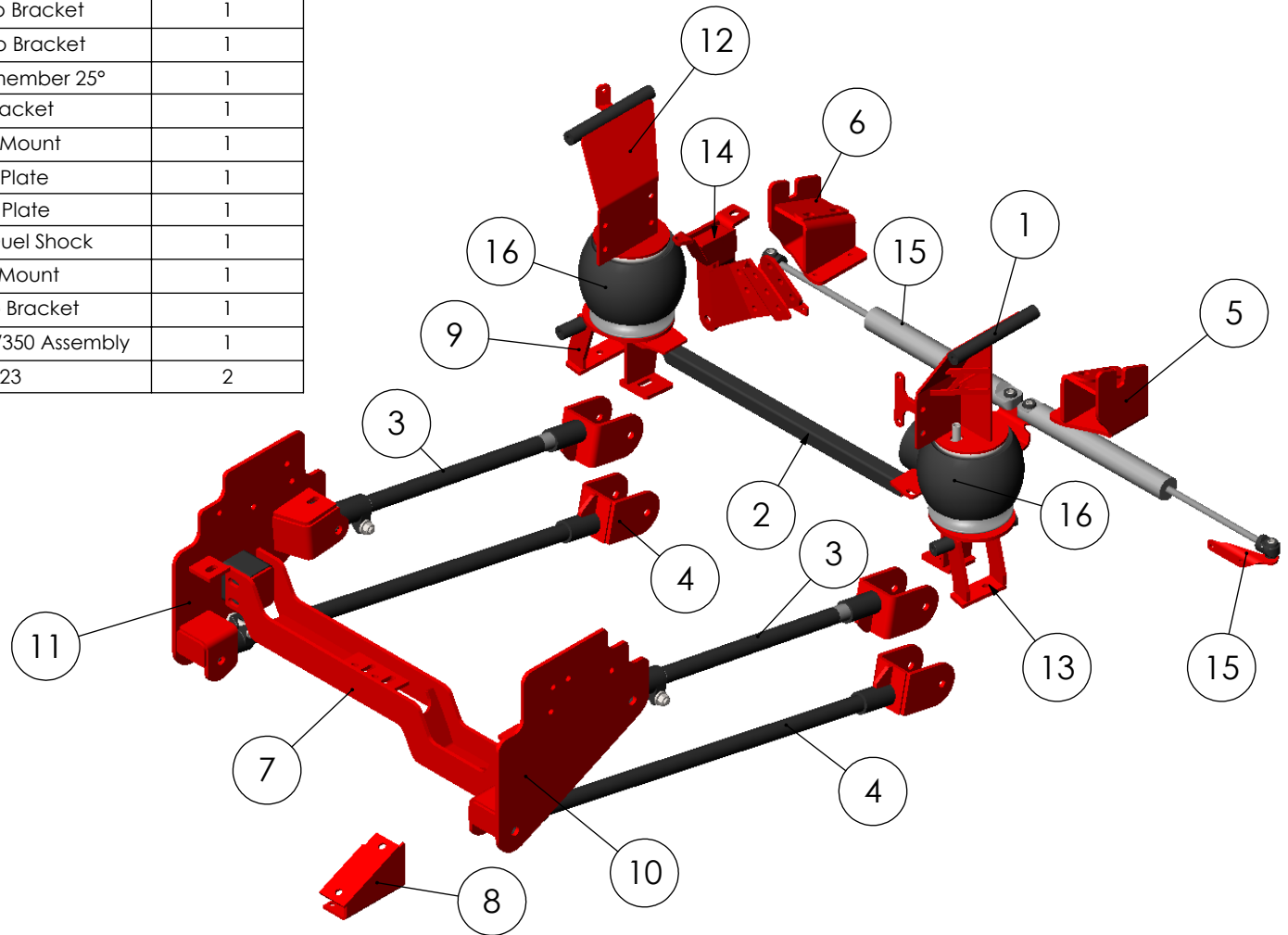

UNLESS OTHERWISE SPECIFIED: DIMENSIONS ARE IN INCHES TOLERANCES: FRACTIONAL 1/32" ANGULAR: MACH 1 BEND 1 TWO PLACE DECIMAL .030 THREE PLACE DECIMAL .010 MATERIAL FINISH WEIGHT 963.22	Design By:	Zach Beltz 2014	Project: 2011 Ford F250/350
	Shelf # / Qty		
	Inventory		Description: 8-10" Front Lift
	Run Qty:		
	PROPRIETARY AND CONFIDENTIAL THE INFORMATION CONTAINED IN THIS DRAWING IS THE SOLE PROPERTY OF KELDERMAN MFG. INC. ANY REPRODUCTION IN PART OR AS A WHOLE WITHOUT THE WRITTEN PERMISSION OF KELDERMAN MFG. INC. IS PROHIBITED.		SIZE DWG. NO. <b>A</b> F4F4-23-X-11-10
	SCALE: 1:100 DO NOT SCALE DRAWING		SHEET 1 OF 2

