

					 3RD ANGLE PROJECTION	A	DO NOT SCALE DRAWING	1:20	Approximate Weight = lbs
					UNLESS OTHERWISE SPEC. DIMENS. IN INCHES STD. TOLERANCES X.X ± 0.60 X.XX ± 0.30 X.XXX ± 0.10 FRAC. DIM. ± 1/32" Deg. ± 5°	MATL SPECS: DESCRIPTION: Assembly - Dual VIAIR Compressor with Dryer - Installation Kit - Mechanical - Dual Tank			
					PROJECT: Compressor Box				
					PART NUMBER: 30664				
					NOTICE: THIS DOCUMENT AND ITS CONTENTS ARE THE PROPERTY OF KELDERMAN MFG. NO USE OR COPIES MAY BE MADE WITHOUT WRITTEN PERMISSION FROM KELDERMAN				
REV	ECN	CHANGE DESCRIPTION	CHANGE BY	DATE	DESIGN BY:		DATE: 1/27/2020		

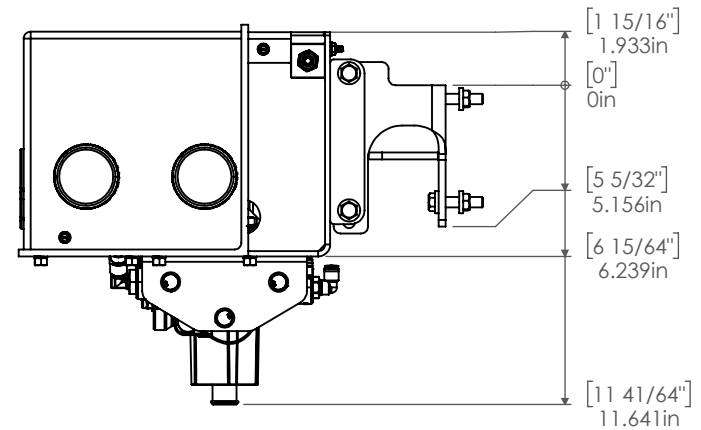

ITEM NO.	PART NUMBER	DESCRIPTION	Default/ QTY.
		<i>Assemblies</i>	
1	15134	Control Panel	1
2	51657	Assembly - Compressor Foot - Vibration Isolater	8
3	51670	Mechanical Alum. Manifold Block w/ Dryer	1
4	51672	Assembly - Collar w/ Ball Stud	2
		<i>Weldments</i>	
5	18157	Weldment - Gast & Dual Vicair Compressor Box	1
6	51703	Weldment - Right Air Compressor Box Mount	1
7	51704	Weldment - Left Air Compressor Box Mount	1
		<i>Parts</i>	
8	41103	Plate - 11ga - Gast Comp. Box Cover w/Bends	1
9	51635	Plate - 11ga - Air Tank Mounting Plate	1
		<i>Purchased Parts</i>	
10	80006	Air Compressor Box Cover	1
11	80016	Straight Air Fitting 1/4"NPT to 1/4" Tube (SMC)	2
12	80057	Hoosier - 7 Port - 3 Gallon - Painted	2
13	80064	Purchased - 444C Air Compressor	2
14	80065	Mechanical Air Dryer	1
15	80067	(BS) 3-Terminal Solenoid Relay 7000-S	1
16	80077	Mechanical Height Control Valve	2
17	80081-3	Linkage	2
18	80083	Straight Male Connector Tube 1/4" x 1/8-27 NPT	4
19	80089	Straight Male Connector Tube 3/8" x 1/4-18 NPT	2
20	80094	90° Male Elbow Tube 1/4" x 1/4-18 NPT	4
21	80095	90° Male Elbow Tube 1/4" x 3/8-18 NPT	2
22	80101	Nylon Air Brake Tubing - (3/8" OD TUBE Color: Black)	22'
23	80102	Nylon Air Brake Tubing - (1/4" OD TUBE Color: Black)	30'
24	80104	Brass Schrader Valve - 1/4" MNPT	1
25	80116	1/4" Tee (Plastic Fitting)	4
26	80124	Male 1/2" NPT to Female 1/4" NPT Fitting	1
27	80125	Male 1/4" NPT to Female 1/4" NPT 90° Fitting	1
28	80168	KV2L11-35s - 90° Elbow, 3/8" x 1/4-18 NPT	2
29	80201	Lanyard Valve Plug - 1/4" NPT	2
30	80202	Safety Valve - 200 PSI - 1/4" NPT (Pop Off)	1
31	80203	Male 1/4" NPT to Male 1/4" NPT 90° Fitting	1
32	80204	Female 1/4" NPT Y-Fitting	1
33	80205	Switch Panel - Harness Pigtail	1
34	80206	Plug - 1/4" NPT, 1/4" Hex Key Size	7
35	80208	Maxi Fuse Holder w/Red Bare Wire, 5" Leads, 6ga Wire, Rated 60A 32V	1
36	80209	Parallel Splice Crimp Connector, 8 AWG, Vinyl Insulated	1
		<i>Hardware</i>	
37	12110	Bolt - 1/4"-20 x 1" - Gr.5	4
38	12211	Bolt - 3/8"-24 X 1" Gr.8	4
39	12218	SCREW-HCS-.38-16X1.75-GR8-YZ	12
40	13000	1/4" Flat Washer	8
41	13002	3/8" Flat Washer	8
42	13022	3/8" Flat Washer	24
43	13100	Nut - Locking - 1/4" - 20 - GR5	4
44	13101	NUT-TLHEX-.31-18-C-YZ	2
45	13102	LOCK NUT - 3/8"-16 GR5	12
46	13122	3/8"-24 Lock Nut	4
47	13836	#10-16 X 3/4 HWH	4
48	13891	M10-1.25 x 25mm	3
49	13893	M10 Lock Washer	3
50	14062	#10 SAE Flat Washer	4
51	14064	#10-32 Hex Nut	2
52	14096	#10-24x3/4" - Hex Head Machine Screw	2
53	80073	Ball Stud	2

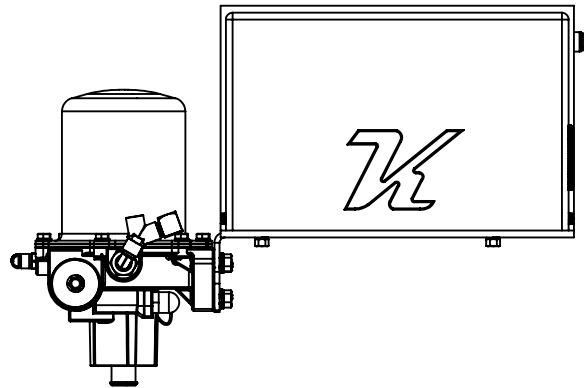
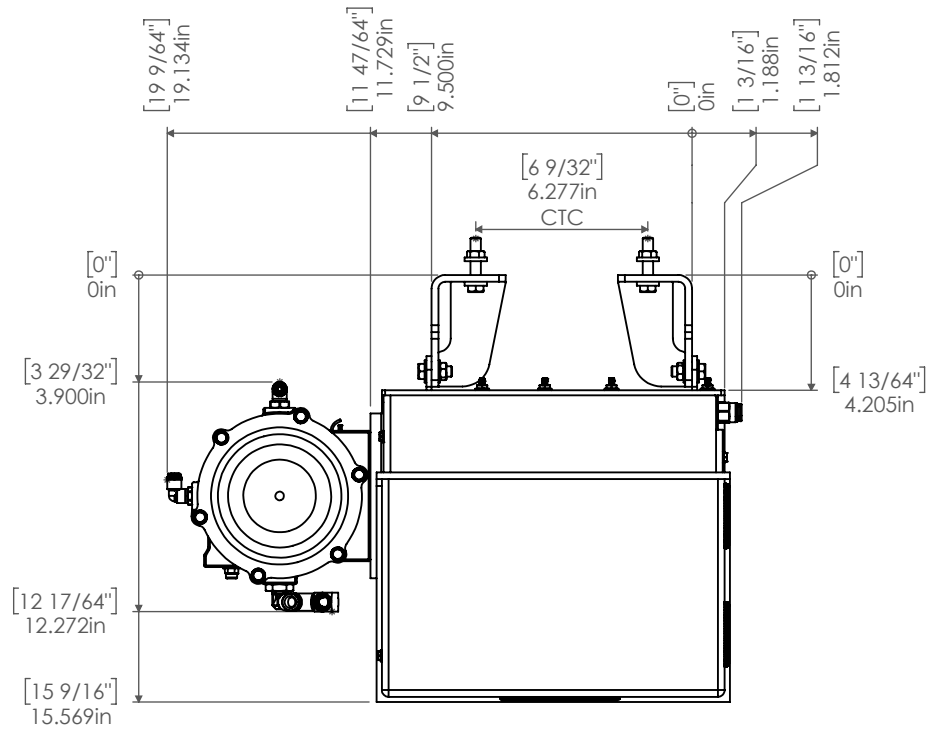

						A DO NOT SCALE DRAWING 1:20 Approximate Weight = lbs
					3RD ANGLE PROJECTION UNLESS OTHERWISE SPEC. DIMENS. IN INCHES STD. TOLERANCES X.X ± 0.60 X.XX ± 0.30 X.XXX ± 0.10 FRAC. DIM. ± 1/32" Deg. ± .5°	MATL SPECS: DESCRIPTION: Assembly - Dual VIAIR Compressor with Dryer - Installation Kit - Mechanical - Dual Tank PROJECT: Compressor Box PART NUMBER: 30664
REV	ECN	CHANGE DESCRIPTION	CHANGE BY	DATE	NOTICE: THIS DOCUMENT AND ITS CONTENTS ARE THE PROPERTY OF KELDERMAN MFG. NO USE OR COPIES MAY BE MADE WITHOUT WRITTEN PERMISSION FROM KELDERMAN.	
					DESIGN BY:	DATE: 1/27/2020

