



2686 Highway 92 - Oskaloosa, IA 52577
phone: 641.673.0468 - fax: 641.673.4168
www.kelderman.com

GM C4500
13.5K, SQUARE AXLE 4-link rear
Installation Instructions

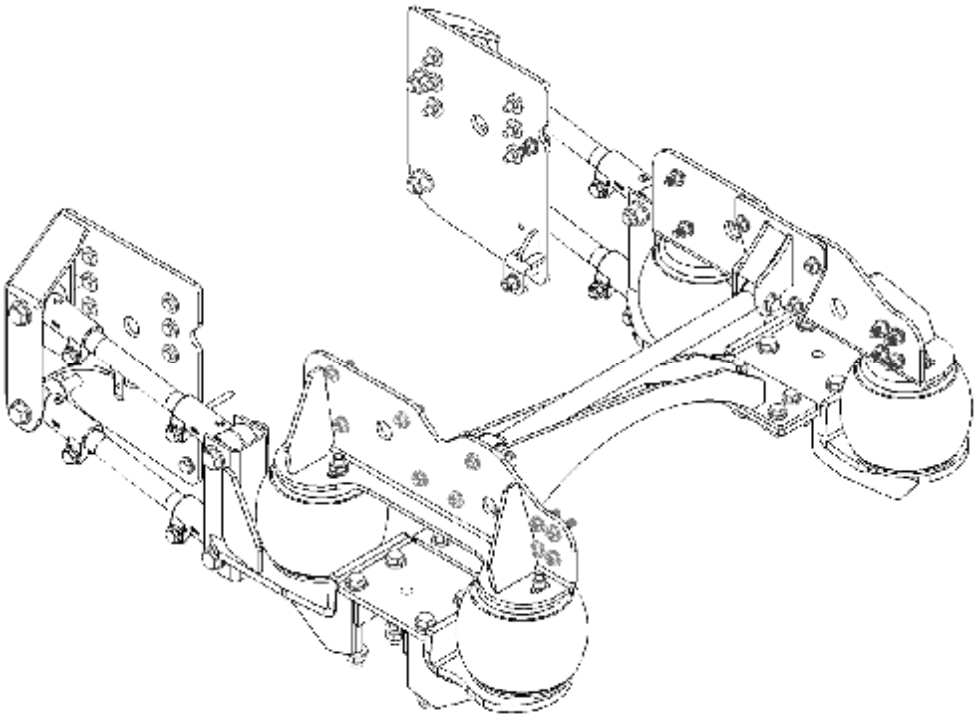

Table of Contents

INSTALLATION INSTRUCTIONS INDEX

- INTRODUCTION.....Pg 3
- EXPLODED ASSEMBLIES.....Pg 4-8
- PARTS LIST.....Pg 5
- PRE-INSTALLATION CHECKLIST.....Pg 9-10
- DISASSEMBLY.....Pg 11-13
- INSTALLATION.....Pg 14-19
- ALIGNMENT.....Pg 20
- AIR CONTROL SYSTEM.....Pg 20

OPERATOR INSTRUCTIONS INDEX

- FINAL INSPECTION CHECKLIST.....Pg 21
- OPERATION GUIDELINES.....Pg 22
- SERVICE & MAINTENANCE.....Pg 23

MISCELLANEOUS INFORMATION

- TORQUE TABLE & DIMENSION SHEET.....Pg 24
- OWNERS GUIDELINES.....Pg 25
- ELECTRIC SCHEMATIC.....Pg 26
- AIR LINE DIAGRAM.....Pg 27
- TROUBLE SHOOTING GUIDE.....Pg 28



INTRODUCTION

IMPORTANT!

It is important that the entire installation instructions be read thoroughly before proceeding with suspension installation.

PRODUCT INSTALLER RESPONSIBILITIES

Installer is responsible for installing the product in accordance with Kelderman Mfg. specifications and installation instructions.

Installer is responsible for providing proper installation of vehicle components and attachments as well as required or necessary clearance for suspension components, air bags, axles, wheels, tires, and other vehicle components to ensure a safe and sound installation and operations.

Installer is responsible for advising the owner of proper use, service, and maintenance required by the product and for supplying maintenance and other instruction as readily available from Kelderman Mfg., Inc.

WARNING

A correct installation must result in the suspension and axle being “loaded” within the range specified by axle and suspension manufacturers. Please check vehicle specifications and intended usage to insure axle will be within Gross Weight Rating (GAWR). No alteration of any suspension component is permitted.



Exploded View

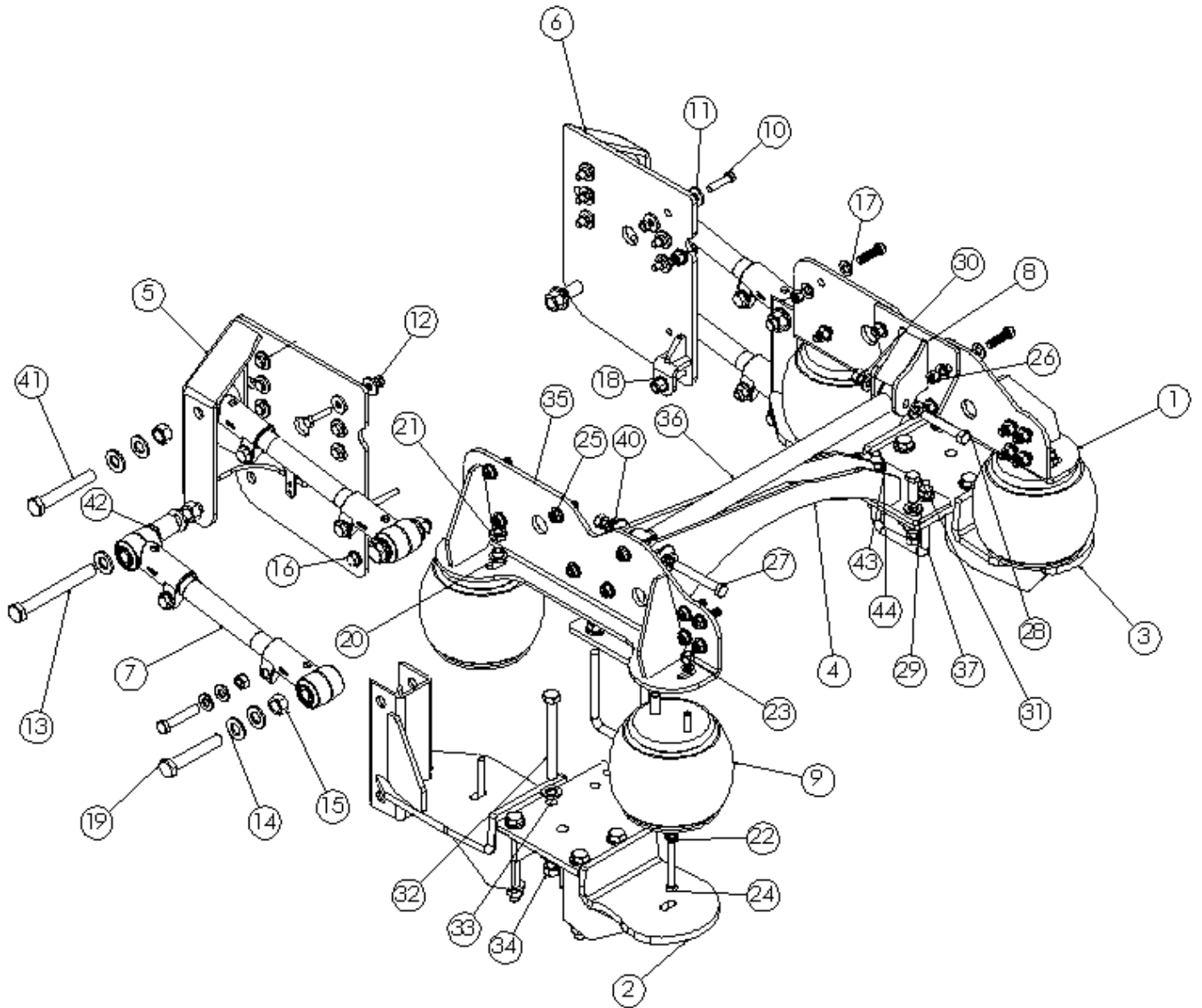

ITEM NO.	PART NUMBER	DESCRIPTION	QTY.
1	17335	RIGHT SIDE UPPER BAG MOUNT	1
2	17337	LEFTSIDE BOTTOM BAG ASSEMBLY	1
3	17338	RIGHTSIDE BOTTOM BAG ASSEMBLY	1
4	17339	CROSSMEMBER	1
5	17331	LEFT SIDE MOUNTING ASSEMBLY	1
6	17330	RIGHTSIDE MOUNTING ASSEMBLY	1
7	15960	TRAILING ARM- 19"	4
8	17333	PHB FRAME MOUNT ASSEMBLY	1
9	10019-X-3	FIRESTONE AIR BAG - 5323 (7 1/2" HT X 9.1" WD)	4
10	12011	BOLT- 1/2"-20 X 2" GR8	12
11	13024	1/2" FLATWASHER - 17/32" ID X 1 1/16" OD X 3/16" THK	28
12	13164	HEX NUT - 1/2"-20 GR8	12
13	12649	BOLT - 7/8"-14 X 7 1/2" GR8	2
14	13030	7/8" FLATWASHER - 29/32" ID X 1 3/4" OD X 11/64" THK	16
15	13170	HEX NUT - 7/8"-14 GR8	8
16	12323	BOLT - 9/16"-18 X 3 1/2" GR8	2
17	13025	9/16" FLATWASHER - 19/32" ID X 1 5/32" OD X 5/64" THK	46
18	13205	HEX JAM NUT - 5/8"-18 GR2	2
19	12629	BOLT - 7/8"-14 X 5" GR8	4
20	13056	3/4" LOCK WASHER - 49/64" ID X 1 17/64" OD X 3/16" THK	4
21	13208	HEX JAM NUT - 3/4"-16 GR8	4
22	13050	1/2" LOCK WASHER - 17/32" ID X 7/8" OD X 1/8" THK	8
23	13204	HEX JAM NUT - 1/2"-20 GR2	4
24	12029	SCREW-HCS-.50-20X4.00-GR8-YZ	4
25	12309	HEX HEAD CAP SCREW - 9/16"-18 X 2" GR8 ZINC PLATED	21
26	13177	HEX NUT - 9/16"-18 GR8	21
27	12431	BOLT-5/8"-18X 4 1/2" GR8	1
28	12427	BOLT - 5/8"-18 X 4" GR8	1
29	13026	5/8" FLATWASHER - 25/32" ID X 1 5/16" OD X 11/64" THK	12
30	13166	HEX NUT - 5/8"-18 GR8	6
31	12409	BOLT - 5/8"-18 X 2" GR8	4
32	12553	BOLT - 3/4"-16 X 9" GR8	8
33	13028	3/4" FLATWASHER - 13/16" ID X 1 15/32" OD X 3/16" THK	16
34	13168	HEX NUT - 3/4"-16 GR8	8
35	17334	LEFT SIDE UPPER BAG MOUNT	1
36	17332	PANHARD BAR 26 1/4"	1
37	13810	U-BOLT 1/2"-13 - 6 1/4" X 4 7/8"	2
38	13124	HEX LOCK NUT - 1/2"-20 GR8	-
39	13004	1/2" FLATWASHER - 17/32" ID X 1 1/16" OD X 7/64" THK	-
40	16955	PHB SPACER 2" X 3/16" D 5/8"	2
41	12633	BOLT - 7/8"-14 X 5 1/2" GR8	2
42	14577	7/8" TUBE SPACER - 29/32" ID X 1 1/2" OD X 1 29/32" THK	2
43	13006	5/8" FLATWASHER - 11/16" ID X 1 5/16" OD X 3/16" THK	4
44	13126	HEX NUT - 5/8"-18 GR8	4

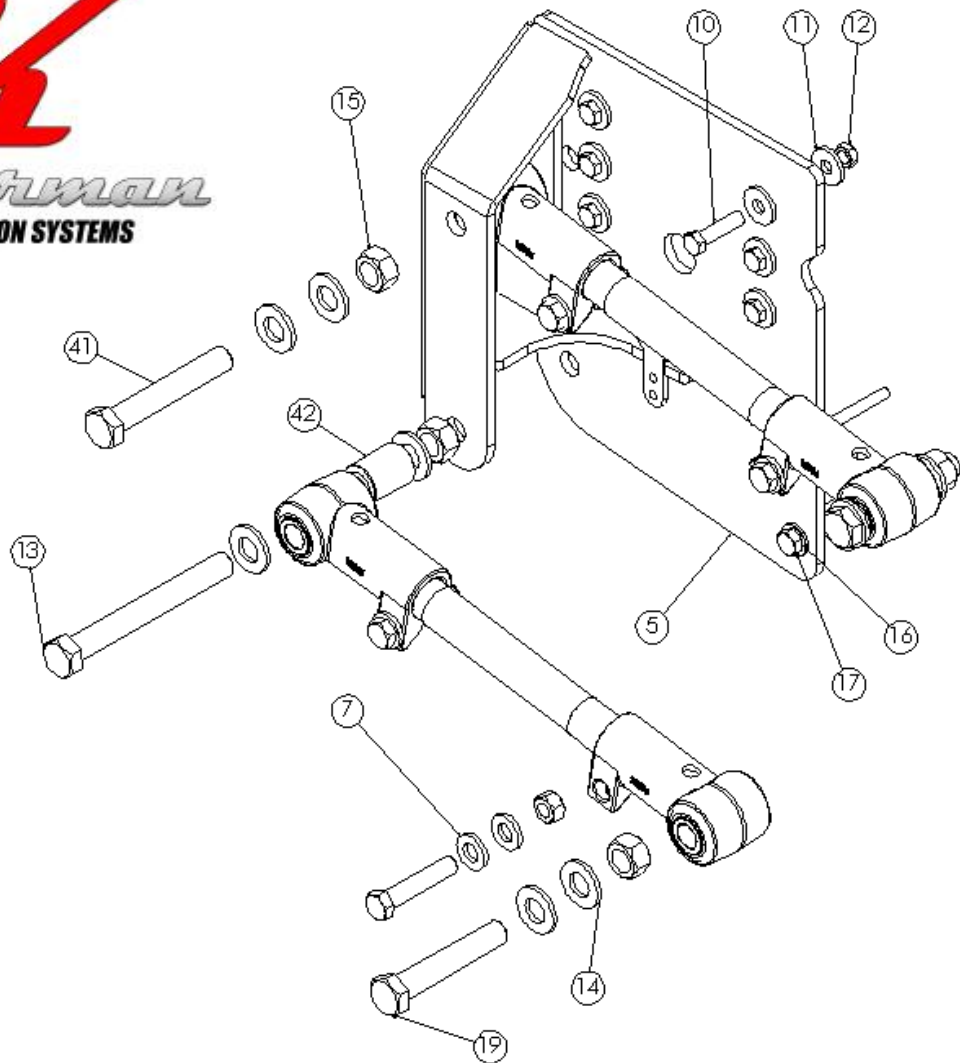

ITEM NO.	PART NUMBER	DESCRIPTION	QTY.
5	17331	LEFT SIDE MOUNTING ASSEMBLY	1
7	15960	TRAILING ARM - 19"	2
10	12011	BOLT - 1/2"-20 X 2" GR8	6
11	13024	1/2" FLAT WASHER - 17/32" ID X 1 1/16" OD X 3/16" THK	12
12	13164	HEX NUT - 1/2"-20 GR8	6
13	12649	BOLT - 7/8"-14 X 7 1/2" GR8	1
14	13030	7/8" FLAT WASHER - 29/32" ID X 1 3/4" OD X 11/64" THK	8
15	13170	HEX NUT - 7/8"-14 GR8	4
16	12323	BOLT - 9/16"-18 X 3 1/2" GR8	1
17	13025	9/16" FLAT WASHER - 19/32" ID X 1 5/32" OD X 5/64" THK	2
18	13205	HEX JAM NUT - 5/8"-18 GR2	1
19	12629	BOLT - 7/8"-14 X 5" GR8	2
41	12633	BOLT - 7/8"-14 X 5 1/2" GR8	1
42	14577	7/8" TUBESPACER - 29/32" ID X 1 1/2" OD X 1 29/32" THK	1

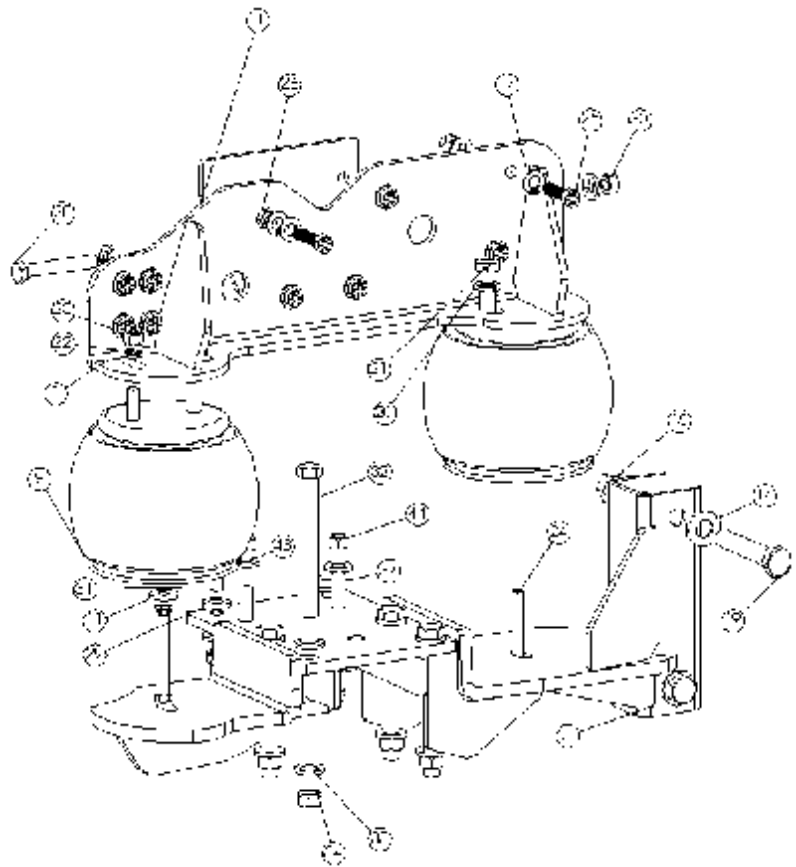

ITEM NO.	PART NUMBER	DESCRIPTION	QTY.
1	17335	RIGHT SIDE UPPER BAG MOUNT	1
3	17338	RIGHT SIDE BOTTOM BAG ASSEMBLY	1
8	17333	PHB FRAME MOUNT ASSEMBLY	1
9	10019-X-3	FIRESTONE AIR BAG - 5323 (7 1/2" HT X 9.1" WD)	2
19	12629	BOLT - 7/8"-14 X 5" GR8	2
14	13030	7/8" FLAT WASHER - 29/32" ID X 1 3/4" OD X 11/64" THK	4
15	13170	HEX NUT - 7/8"-14 GR8	2
20	13056	3/4" LOCK WASHER - 49/64" ID X 1 17/64" OD X 3/16" THK	2
21	13208	HEX JAM NUT - 3/4"-16 GR8	2
22	13050	1/2" LOCK WASHER - 17/32" ID X 7/8" OD X 1/8" THK	4
23	13204	HEX JAM NUT - 1/2"-20 GR2	2
24	12029	SCREW-HCS-.50-20X4.00-GR8-YZ	2
11	13024	1/2" FLAT WASHER - 17/32" ID X 1 1/16" OD X 3/16" THK	2
25	12309	HEX HEAD CAP SCREW - 9/16"-18 X 2" GR8 ZINC PLATED	10
17	13025	9/16" FLAT WASHER - 19/32" ID X 1 5/32" OD X 5/64" THK	20
26	13177	HEX NUT - 9/16"-18 GR8	10
28	12427	BOLT - 5/8"-18 X 4" GR8	1
29	13026	5/8" FLAT WASHER - 25/32" ID X 1 5/16" OD X 11/64" THK	6
30	13166	HEX NUT - 5/8"-18 GR8	3
31	12409	BOLT - 5/8"-18 X 2" GR8	2
32	12553	BOLT - 3/4"-16 X 9" GR8	4
33	13028	3/4" FLAT WASHER - 13/16" ID X 1 15/32" OD X 3/16" THK	8
34	13168	HEX NUT - 3/4"-16 GR8	4
37	13810	U-BOLT 1/2"-13 - 6 1/4" X 4 7/8"	1
43	13006	5/8" FLAT WASHER - 11/16" ID X 1 5/16" OD X 3/16" THK	2
44	13126	HEX NUT - 5/8"-18 GR8	2

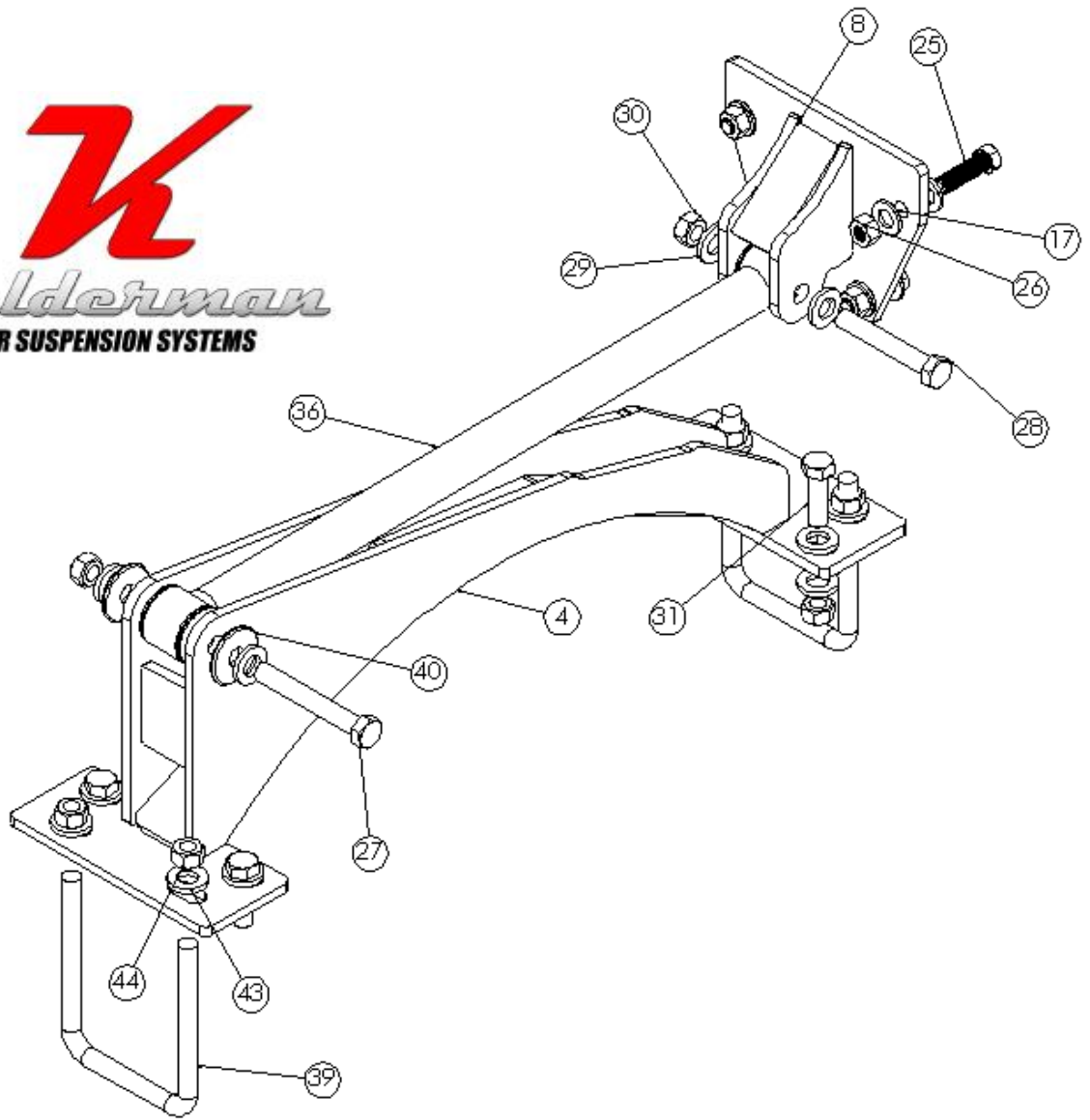

ITEM NO.	PART NUMBER	DESCRIPTION	QTY.
4	17339	CROSSMEMBER	1
8	17333	PHB ASSEMBLY	1
25	12309	HEX HEAD CAP SCREW - 9/16"-18 X 2" GR8 ZINC PLATED	4
17	13025	9/16" FLAT WASHER - 19/32" ID X 1 5/32" OD X 5/64" THK	8
26	13177	HEX NUT- 9/16"-18 GR8	4
27	12431	SCREW-HCS-.63-18X4.50-GR8-YZ	1
28	12427	BOLT - 5/8"-18 X 4" GR8	1
29	13026	5/8" FLAT WASHER - 25/32" ID X 1 5/16" OD X 11/64" THK	11
30	13166	HEX NUT- 5/8"-18 GR8	5
31	12409	BOLT - 5/8"-18 X 2" GR8	4
36	17332	PHB 26 1/4"	1
39	13810	U-BOLT 1/2"-13 - 6 1/4" X 4 7/8"	2
40	16955	PHB SPACER 2" X 3/16"-D 5/8"	2
43	13006	5/8" FLAT WASHER - 11/16" ID X 1 5/16" OD X 3/16" THK	4
44	13126	HEX NUT- 5/8"-18 GR8	4

PRE-INSTALLATION CHECKLIST

Check the vehicle wheel alignment prior to installation to insure no precondition already exists; record information for verification. It is not unusual for the measurements to be off side to side.

Measure and record the wheelbase and centering dimensions before beginning installation.

Measure and record height from the ground up to the rear of the frame.

Measure and record the pinion angle. *See page 10 for specific instructions.*

Remove the attached body, if applicable. Remember to disconnect all electrical connections and fuel filler tube, before removing the body. The installation can also be completed using a lift to raise the vehicle. If using a lift, chassis body removal may not be necessary but removal of rear wheels will aid in installation.

If not using a lift, block the front wheels so the vehicle cannot roll.

Jack up the rear frame of the truck in order to unload the rear leaf springs. Do not lift the wheels off the ground. Do not jack on axle itself.

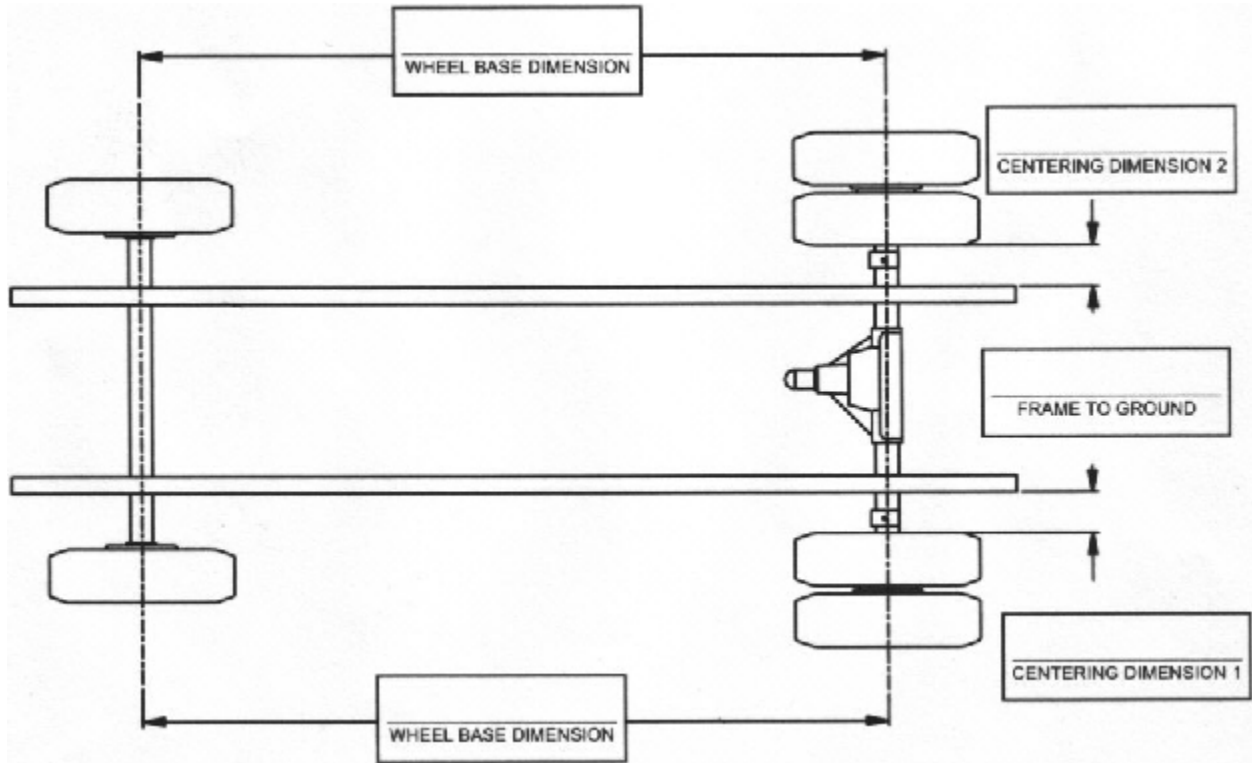

DISASSEMBLY

1. With weight taken off the rear springs, as noted in pre-installation checklist, remove the mount bolts or rivets from the Front Leaf Spring Hanger Bracket. Remove the bolts or rivets attaching the Rear Leaf Spring Hanger Bracket. **DO NOT** re-use the fasteners that mount the hanger bracket, or leaf spring itself. New fasteners are provided, and must be used to achieve proper clamp load on the front trailing arm mount hanger.

**REMOVE THESE
BOLTS THEY WILL
NOT BE REUSED
IF RIVETS ARE USED
CIT THEM OFF WITH A
TORCH, PLASMA CUT-
TER OR RIVET
BUSTER**

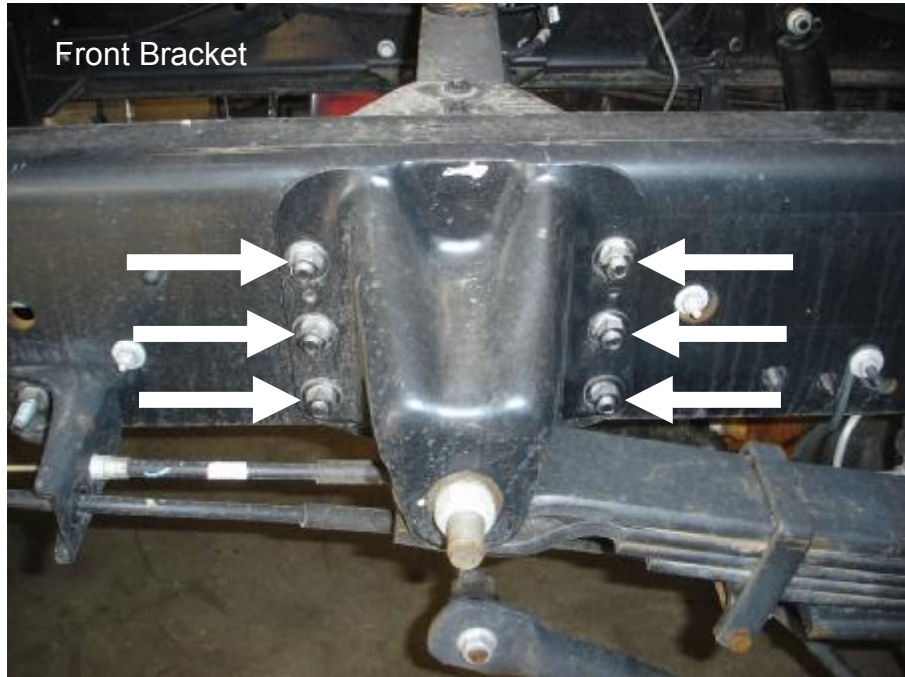

**REMOVE THESE
BOLTS THEY WILL
NOT BE REUSED
IF RIVETS ARE USED
CIT THEM OFF WITH A
TORCH, PLASMA CUT-
TER OR RIVET
BUSTER**

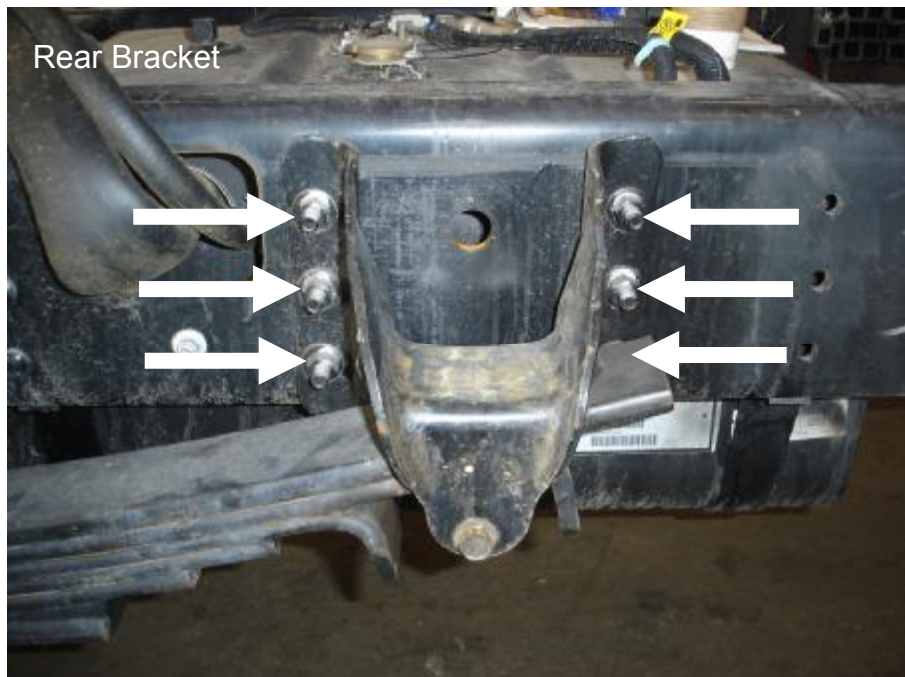

2. Remove the OE Jounce Bumper Bracket. It will not be reused.

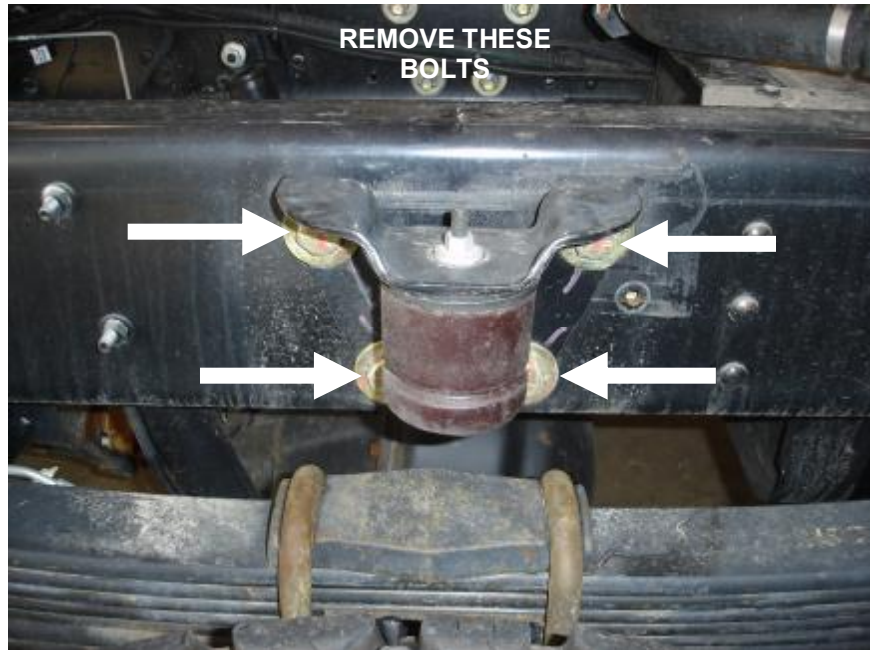

NOTE: Verify orientation of lower axle wedge. Make sure to install the same way during reassembly.

3. Remove existing U-bolts that attach the axle to the leaf spring. After this is done, axle, spring, and hanger will be loose on this side. Remove the leaf spring and its mounting brackets from the vehicle. Rear Leaf Spring Hanger Bracket can now be removed completely. Repeat on other side.

4. Grind/remove the two rivets shown below that connect the forward fuel tank cross-member to the frame. It can be removed by grinding, or air chiseling, the head off the factory-installed rivet.

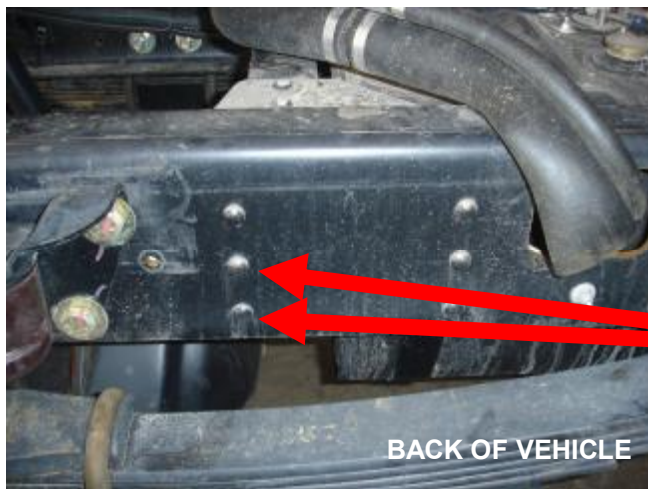

5. The OEM stabilizer end link and mounting bracket must be removed. The OEM stabilizer end link will need to be reinstalled later. Discard the mount.

6. Repeat this procedure for driver's side of vehicle.

REMOVE THIS RIVET BY GRINDING OR CHISELING FROM FRAME RAIL

DETERMINING PINION ANGLE

The pinion angle is critical in the correct installation of your Kelderman Air Ride Suspension System. The pinion angle can be easily determined with the use of a magnetic angle gauge.

To measure the angle, find a flat surface to attach the angle gauge. Mark the location of your gauge with a marking pen or scribe. Record the angle on the gauge. For future reference.

Note: It may not be necessary to remove gauge. Marking the position of the gauge is critical to ensure accurate angle readings during adjustment steps of the assembly of your Kelderman Air Ride Suspension System.



Pinion Angle: _____°



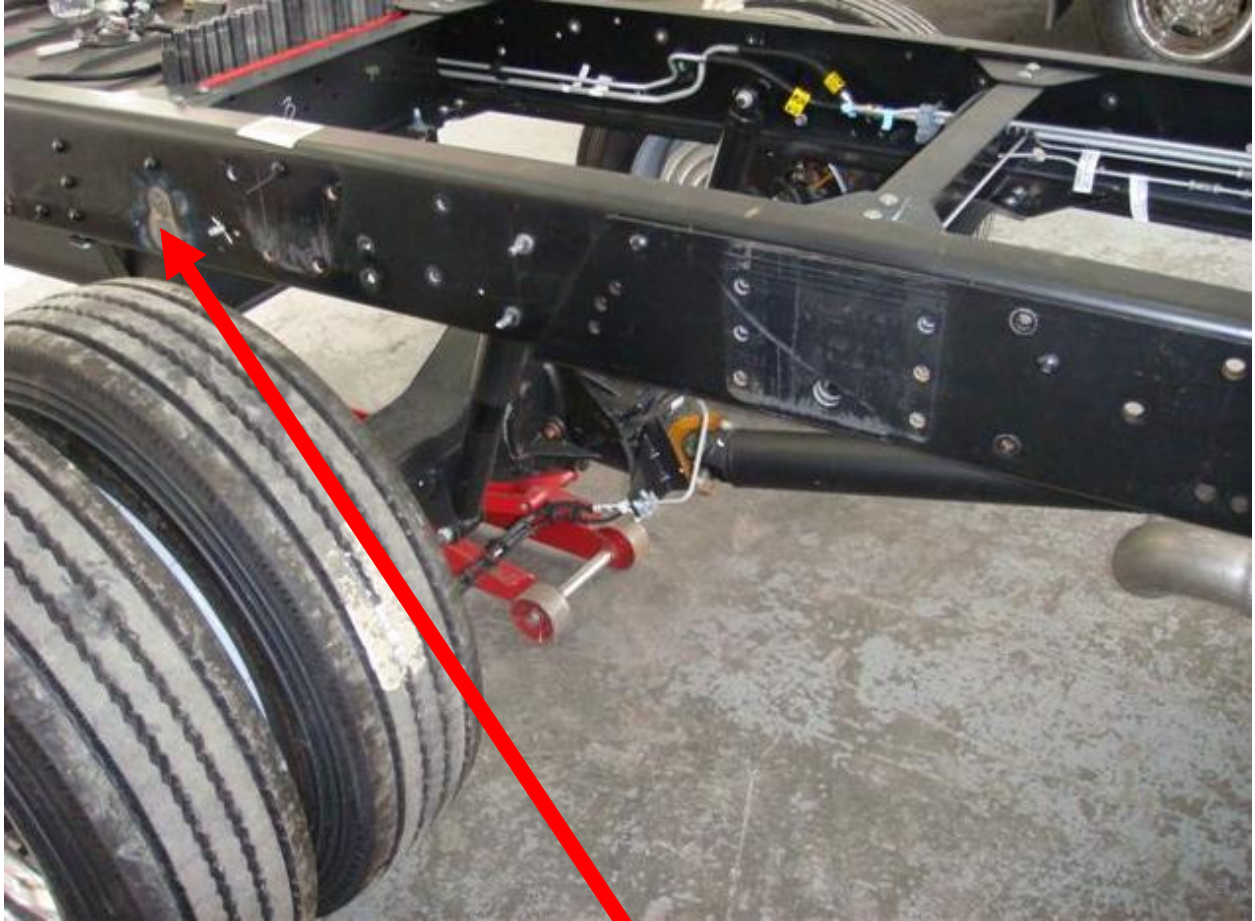

**REMOVE THESE
RIVETS BY GRINDING
OR CHISELING FROM
FRAME RAIL**

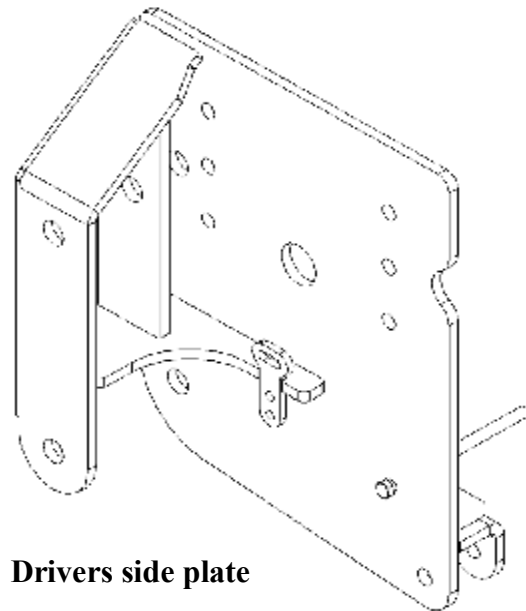

Drivers side plate

ASSEMBLY

NOTE: All bolts will use a flat washer on each end of the bolt.

6) 1/2x2" bolts

1. On driver's side of vehicle, install the 4-Link Side Plate onto the frame rail utilizing the holes that were used by the front leaf spring hanger bracket. Secure with 6 bolts (1/2" x 2"), 12 flat washers (1/2") and 6 top lock nuts (1/2") installed from the inside of the frame out. **Torque the bolts to 135 ft. lbs.** When possible, insert the bolts from the inside of the frame pointing outwards.

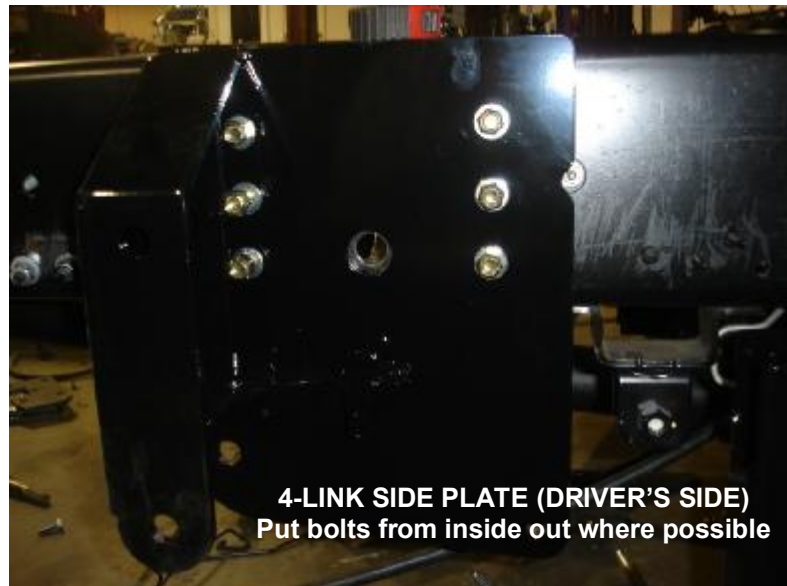

4-LINK SIDE PLATE (DRIVER'S SIDE)
Put bolts from inside out where possible

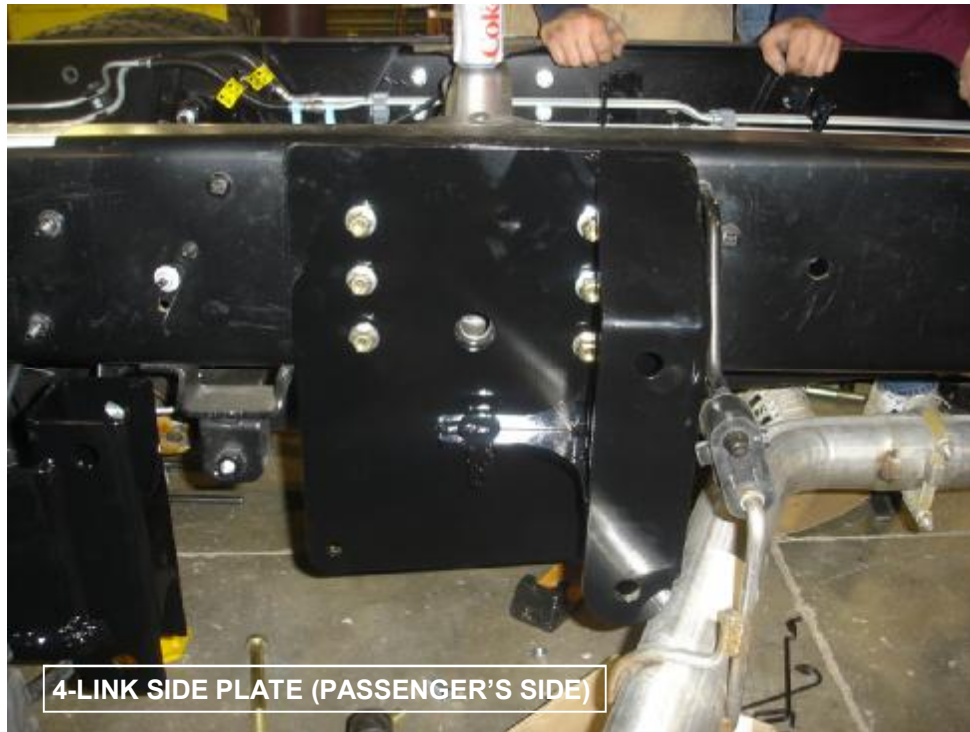

2. On passenger's side of vehicle, install the 4-Link Side Plate onto the frame rail utilizing the holes that were used by the front leaf spring hanger bracket. Secure with 6 bolts (1/2" X 2"), 12 flat washers (1/2"), and 6 top lock nuts (1/2") installed from the outside of the frame. **Torque the bolts to 135 ft./lbs.**

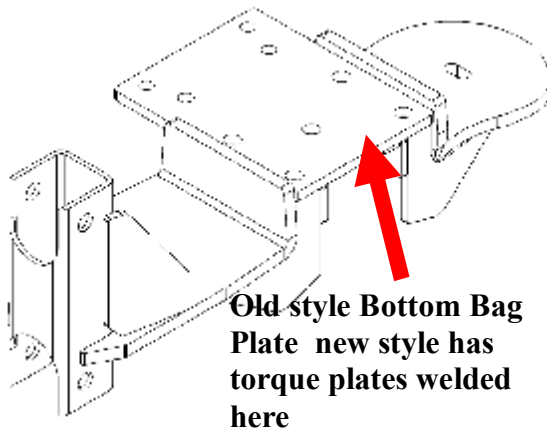

NOTE: If you vehicle has a box on it or utility bed, may be necessary to install the trailing arms into the front mounts before you install them into the frame. To do so, use the 7/8" X 5 1/2" bolt to fasten the upper trailing arm. On the bottom, use the 7/8" X 7 1/2" bolts and spacers. Make sure to put the spacer on the inside of the knuckle and the trailing arm mount.

3. Locate the lower air bag mounts. Slide the lower bag mounts over the axle. Use the centering pin to locate the mount on the leaf spring perch. Locate the torque plate mounting brackets. Drop the 3/4x9 1/2" bolts down through the Next locate the factory lower air axle clamps. Use the 3/4" nuts and flat washers to fasten the factory lower axle clamp to the bottom of the axle. Do not tighten yet. **MAKE SURE THE FACTROY LOWER AXLE CLAMP IS INSTALLED WITH THE ANGLE IN STEP TWO.** Once the lower pan hard bar mount/axle cross member is installed in step 7, you will **torque the 3/4" nuts to 250 ft/lb.**

5. Locate the upper bag mounts and the passengers side pan hard bar mount. Fasten the drivers side upper bag mounts to the frame with the eight 1/2" X 2" bolts.

6. Next, fasten the passengers side upper bag mount to the frame using the 1/2" X 2" bolts in the outer holes. Use the 1/2" X 2 1/2" bolts on the inside set of holes that fasten the track bar mounting bracket. (Refer to page 7 and 17)

7. Locate the lower pan hard bar mount/axle cross member. The tall ears go on the drivers side. Fasten the mount to the axle with the 5/8" X 7 1/2" bolts and the lower axle mount. Also use the 5/8"X 2 1/2" bolts to fasten the lower air bag mount to the cross member. Once all these are started, **torque to 150 ft/lbs.** Now go back and torque the 3/4" bolts to **250 ft/lbs.**

Driver's side 

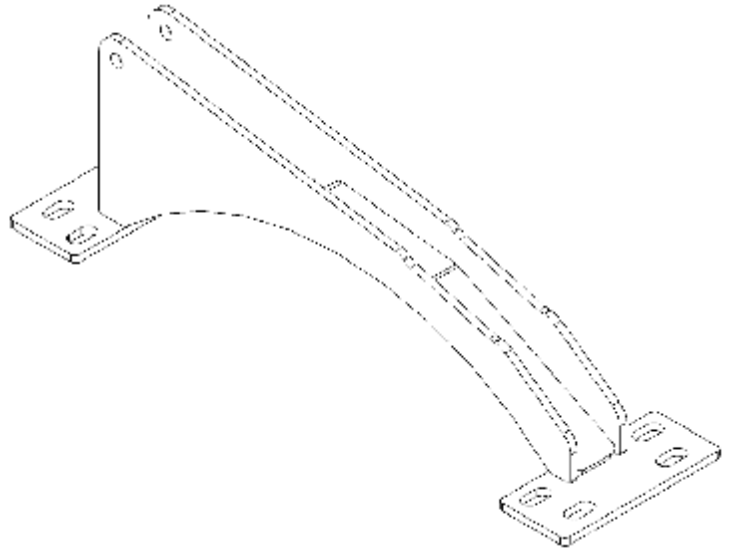

Early style lower bag mount installed. Torque plate mounting bracket goes here. New style has plate welded here.

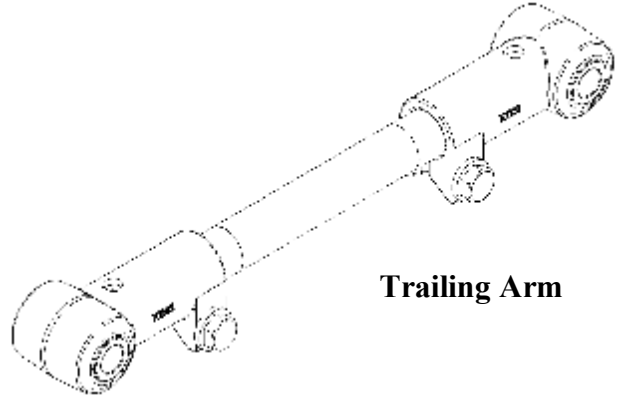

Trailing Arm

Spacer

8. Locate the trailing arms. If you have not already installed them in the front trailing arm mounts, use the 7/8" X 5 1/2" bolt to fasten the front upper trailing arm. The upper rear bolt is 7/8x6 1/2" Insert the bolt from the inside out. Put on the spacer and then install the torque plate. Use the 3/4x2 1/2" bolt to fasten the torque plate to the torque plate mounting bracket. On the bottom, use the 7/8" X 7 1/2" bolts and spacers. Make sure to put the spacer on the inside of the knuckle and the trailing arm mount. Use the 7/8" X 5 1/2" bolts to fasten the rear of the trailing arms to the lower air bag plates. Once the install is complete and the bags are at ride height. **Torque the 7/8" bolts to 310 ft/lbs.**

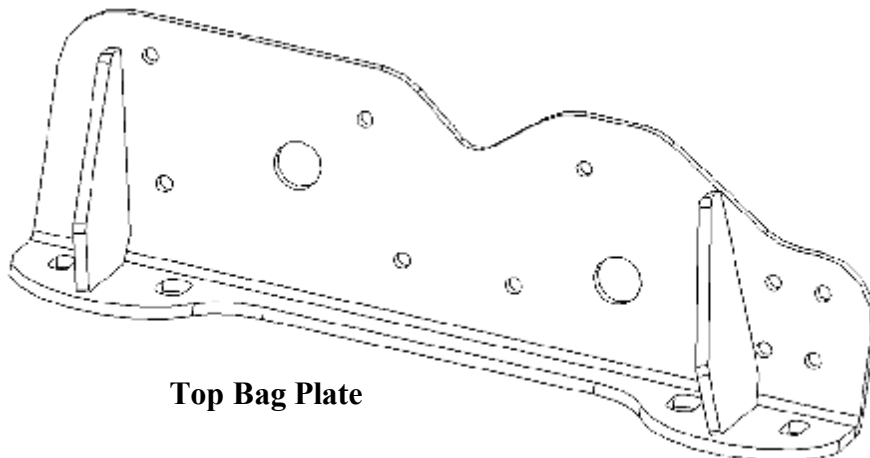

Top Bag Plate

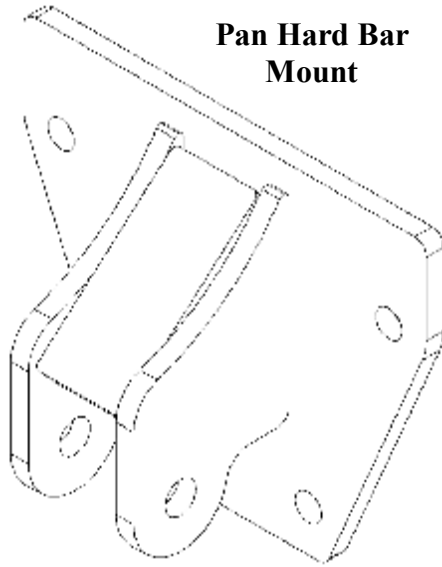

Pan Hard Bar Mount



9. Fasten the top of the air bags to the upper air bag mounts using the 1/2" and 3/4" nuts and lock washers. Center the bags in the slots so each bag is the same. Take notice so make sure that the rear passengers side bag is not close to the exhaust. If needed, push the bag to the outer part of the slot to make more clearance. Once the bag is positioned, **torque the 1/2" bolts to 35 ft/lbs and the 1/2" and 3/4" nuts to 35 ft/lbs.**

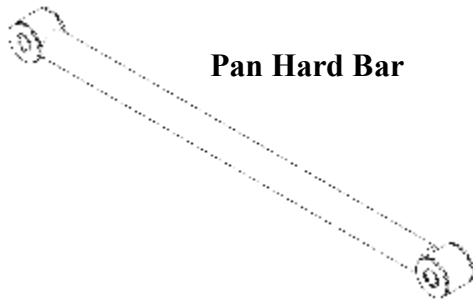

Pan Hard Bar

10. Locate the pan hard bar. Insert the pan hard bar into the axle cross-member. Make sure to use one of the spacers on each side of the bushing. Use the 5/8" X 4 1/2" bolt on the taller end of the cross-member. Use the 5/8" X 4" bolt in the other end. **Torque the bolts to 150 ft/lbs. (Refer to page 8.)**

11. Reattach the OEM rear anti-sway end links to the 4-Link Side Plates with the 9/16x4" bolts. **Torque to 150 ft/lbs. (page 13)**



Sway Bar End Link

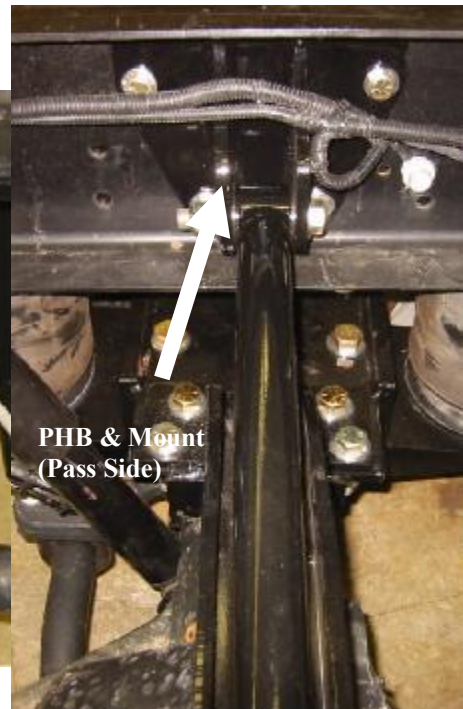

PHB & Mount (Pass Side)

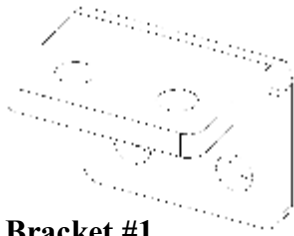

Bracket #1

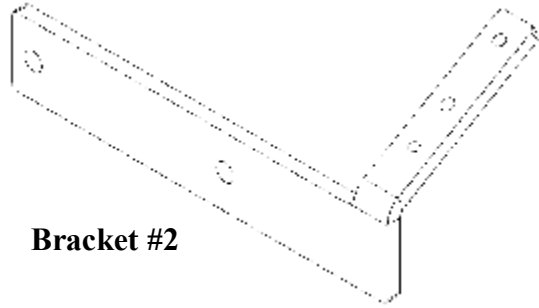

Bracket #2

12. If the vehicle has the brake calipers on the rear, it is required to install the parking brake relocation bracket #1. If the calipers are on the front, use parking brake relocation bracket #2. Bracket #1 uses two 1/2" X 1 1/2" bolts. Bracket #2 uses the four 1/2" X 2" bolts and 4 1/4" X 1" bolts. These mount to the frame_____

Haldex height control valve pictured

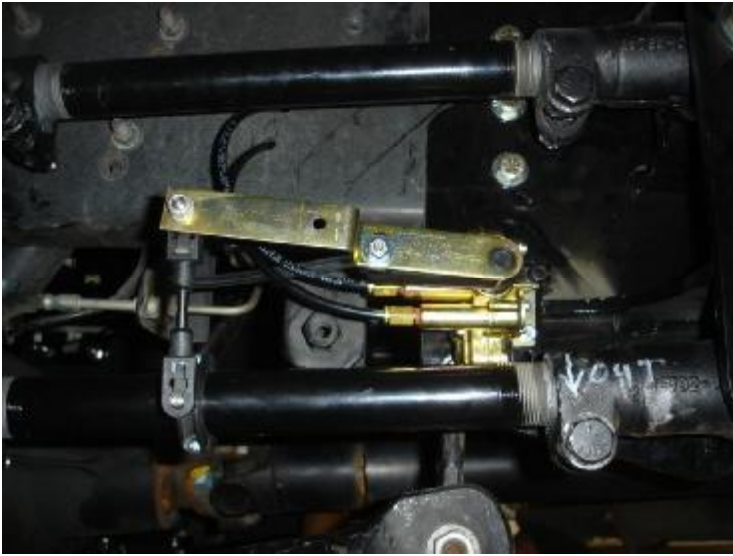

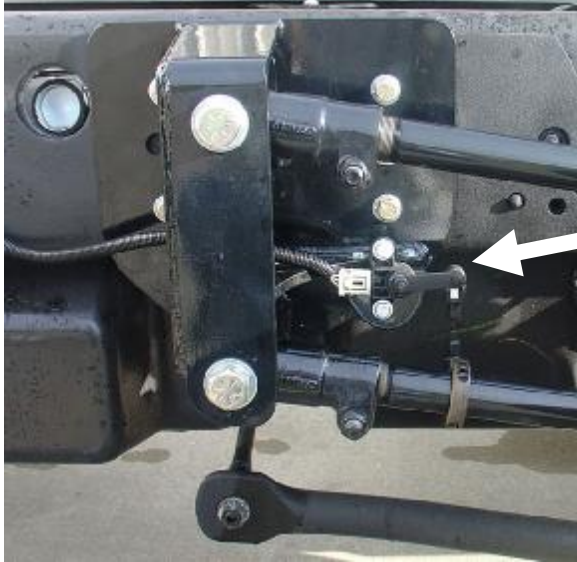

ADJUSTING WHEEL BASE / PINION ANGLE

1. With the vehicle lifted to ride height on jack stands, let the air out of the air-bags. Check wheel base measurement on the vehicle. To adjust the wheelbase, turn either both left or both right 4-Link Bars. **Always turn them the same direction and only 1/2 turn at a time.** Keep checking measurement and adjusting until your wheelbase measurement is the same as initial measurement. Once the alignment is done, **torque the pinch bolts on the 4-Link Bars to 75 ft. /lbs.**

Electronic height control sensor pictured

AIR COMPRESSOR / CONTROL SYSTEM

1. *Plumbing of the system.* Insert the fittings in the top of the four air bags. Locate the Neway height control valve and use the 1/4" X 1 1/4" bolts to fasten the height control valve to the front trailing arm bracket on the driver's side. Mount the ball to the end of the height control valve, fasten the lock collar to the lower control arm and connect the linkage between them.
2. *Locate the compressor box.* Mount the box somewhere on the frame, preferably on the driver's side frame rail. Use the wiring diagram provided at the end of the instruction packet to wire up the system. Also provided is an air line diagram.
3. *Locate the air tank.* Find an area on the frame to mount it. Make sure the drain plug is facing straight down.
4. Once you have the compressor wired up, the air line going to the air tank, run an air line from the air tank to the bottom port of the height control valve. Locate the clear line and plastic fitting supplied with the height control valve and install it in the top port. This is the exhaust. Next locate the three brass "T" fittings. Connect the two air bags on each side with a "T" fitting. Next, connect the right side and left sides together with another "T" fitting. Connect this "T" fitting to the CYL port on the dump valve. Last, connect an air line from supply port to middle port on the height control valve.

FINAL INSPECTION CHECKLIST

1. Air System Start Up and Check - remove all jacks, next air the system up by either using the fill valve on the air tank or by starting the vehicle and switching the compressor switch to "ON".
Note: the maximum allowable pressure in the air tank is 175 psi. It is recommended to fill the air tank using the supplied Schrader valve so that the compressors are not taxed too much by running for a long period of time.
2. Height Control Valve Operation Check - with one end of the valve linkage disconnected, rotate the valve arm down 45°, air should exhaust from the air bag. Rotating the valve arm up 45° should cause the valve to fill the air bag.

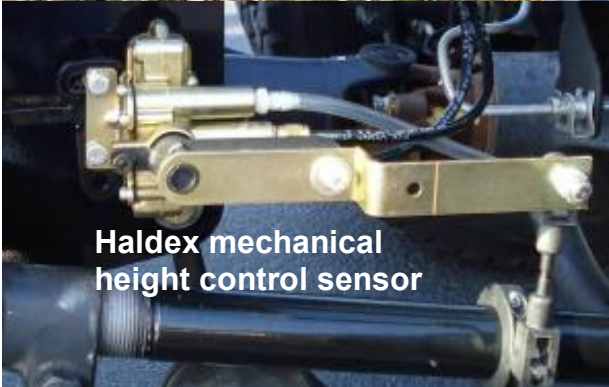

AIR LINE ROUTING

1. Attach air line to fitting on passenger side of vehicle. Route line under frame rail, and forward through hole in cross member on frame. Attach air line to fitting on driver side of vehicle. Route this line under frame rail and forward through hole in cross member. Route these lines together in the middle of the vehicle and attach to run sides tee fitting. Attach air line to branch side of fitting. Route this line forward along the inside of the frame rail on the driver side of the vehicle. Attach to fitting in air control assembly.

See note on page 23 for initial use of air compressor.

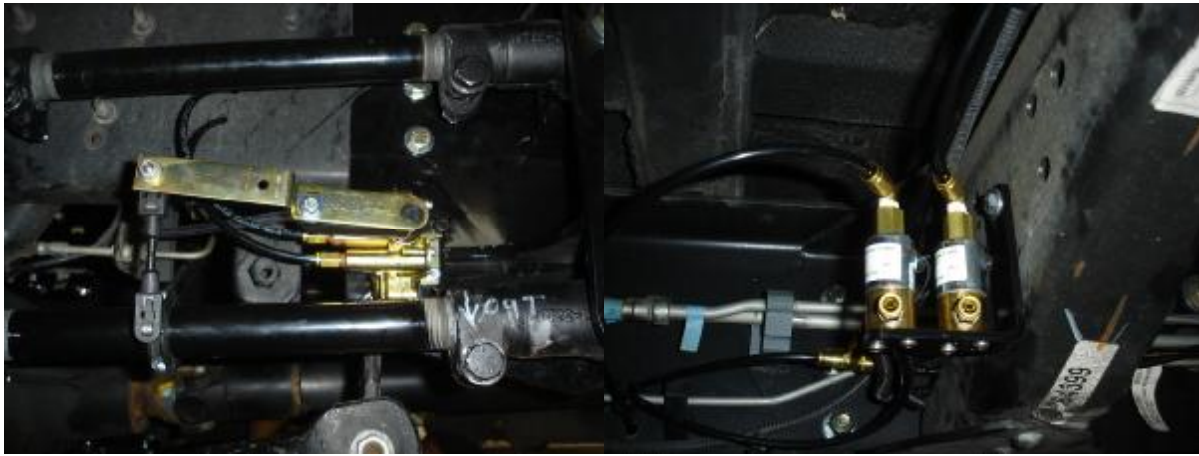

Measure & Record the “Ride Height” of the air bag - measure ride height of the air bag from upper air bag mount to lower air bag mount (see Figure below). To adjust the ride height, complete the following steps (see Figure below). Loosen upper height control valve bolt. Rotating height control valve body toward rear of chassis this will increase the ride height. Rotating height control valve body toward front of chassis will decrease ride height. Tighten upper height control valve bolt. Once the ride height is set, reconnect the linkages. Jostle the suspension up and down and allow it to come back to ride height. Recheck the initial measurement and adjust if needed.

4. Bushing Bolts Final Torque - with the suspension at ride height, torque all bushing fasteners. This will include all fasteners for the Control Arm and Pan Hard Bar. (Refer to *Torque* table for specific torques).
5. Reinstall shocks and mounting nuts.
6. Move the suspension through its entire range of motion by inflating and deflating the air bags to achieve full travel. Check for any interference with the pan hard bar, axle, shocks, exhaust, frame, brake lines, fuel lines, etc. Reconnect valve linkage to trailing arm.
7. Recheck all fasteners for specified torque.
8. Double check all electrical connections and wire routings.
9. **IMPORTANT!** Check all fittings and air lines for air leaks.
10. Measure and record wheelbase and centering dims on final dimension sheet.
11. Reinstall the chassis body (if applicable).

OPERATION GUIDELINES

1. After all final checks are complete, it is recommended to perform a road test. If vehicle pulls to the left or right, or any driveline vibration occurs, return and recheck wheelbase measurements and driveline angles. **Note:** improper driveline angles may have a detrimental affect on ride, U joints, and transmission.

2. **Kneeling Operation:** Moving the dump switch to “ON” position will exhaust all air from the air bags and lower the rear of the vehicle approximately 3-4 inches. Air bags will inflate when the switch is returned to the “OFF” position. **WARNING: Do not drive the vehicle while the Dump Switch is on and the air bags are deflated.**

3. **IMPORTANT!** During servicing check tightness of all fasteners and for any air systems leaks.

4. **IMPORTANT!** Immediate corrective action should be taken if malfunctions occur.

5. Air Bag Ride Height Setting Procedure for Systems with Dual Height Control Valves

1. Deflate the passenger side air bag by disconnecting the linkage from the arm.
2. With the driver side linkage connected, measure the ride height and adjust accordingly by the methods mentioned above.
3. Once the ride height is set for the driver side, repeat the same steps for the passenger side, including deflating the driver side air bag.
4. Once the ride height is set, reconnect the linkages.
5. Jostle the suspension up and down and then allow it to come back to ride height. Recheck the initial measurement and adjust if needed. **Note:** this procedure to set ride height can be done when empty or under light load.

***Test drive:** Once the system is installed, bolts torque, and the air system checked for leaks, the vehicle is now ready for a test drive. The vehicle should drive straight and be without any driveline vibration. If there is shutter upon take off, then the pinion angle is off. This can be adjusted by shortening or lengthening the upper or lower trailing arms. If the truck pulls to the right or left, the alignment is off. Adjust by shortening or lengthening the trailing arms on the same side.

****NOTE:** Once the system is wired up and plumbed, turn on the ignition and the compressor will start running. Upon first start up when there is no air in the tank, it will take around 6-8 minutes until the system is charged, air bags filled. After the compressor shuts off, check for leaks. It works best to use soapy water or gas leak detector sold at hardware stores. Check all the fittings and connections in the entire system.

SERVICE & MAINTENANCE

The Kelderman suspension needs no lubrication and little maintenance. The following components should be checked at the same time the chassis is being serviced. However, immediate corrective action should be taken if a serious malfunction occurs. See Exploded Assembly on page 18 for details.

Caution! If maintenance or service is to be done on the air system, be sure to drain **all** air from system. Serious injury could occur if components are removed while system is full of air.

Note: It is important to release any moisture contained within the air reservoir on a daily basis. Not releasing the moisture on a regular basis will cause the drain valve to not operate properly, and may cause the valve to malfunction. Excess moisture in the system can also cause premature failure of other components including the tank itself.

AIR BAG SERVICE

The forward air bag can be serviced without removing the axle brackets from the axle. Detach the upper air bag mounting studs from the upper bag plate. Now, utilizing a modified 3/4" wrench, the forward air bag lower mounting bolt can be loosened. Then, rotate the air bag counter-clockwise off the lower mounting bolt. Now remove air bag. To install, reverse process.

SERVICE & MAINTENANCE CHECKLIST

1. Check and document rear axle alignment.
2. Verify ride height at 8" between upper and lower air bag mounting plates.
3. Verify suspension function via dump and re-inflation.
4. Check for air leaks and system integrity.
5. Check clearances throughout suspension motion range.
6. Check driveline angle.
7. Check 4 wheel alignment.

TORQUE TABLE

Location	Fastener	Torque
Front trailing arm mounts	5/8" UNF Nuts	150 LB/FT
Lower bag mounts	3/4" UNF Nuts	250 LB/FT
Upper bag mounts	1/2" UNF Nuts	85 LB/FT
Upper bag mounts	5/8" UNF Nuts	150 LB/FT
Air bags	1/2" UNC Nuts	35 LB/FT
Air bags	1/2" UNC Bolts	35 LB/FT
Air bags	3/4" UNF Nuts	35 LB/FT
Pan hard bar	5/8" UNF Nuts	150 LB/FT
Trailing arms	5/8" UNC Nuts	150 LB/FT
Trailing arms	7/8" UNF Nuts	310 LB/FT
Heat shield	5/16" UNC Nuts	100 LB/IN

FINAL DIMENSION SHEET

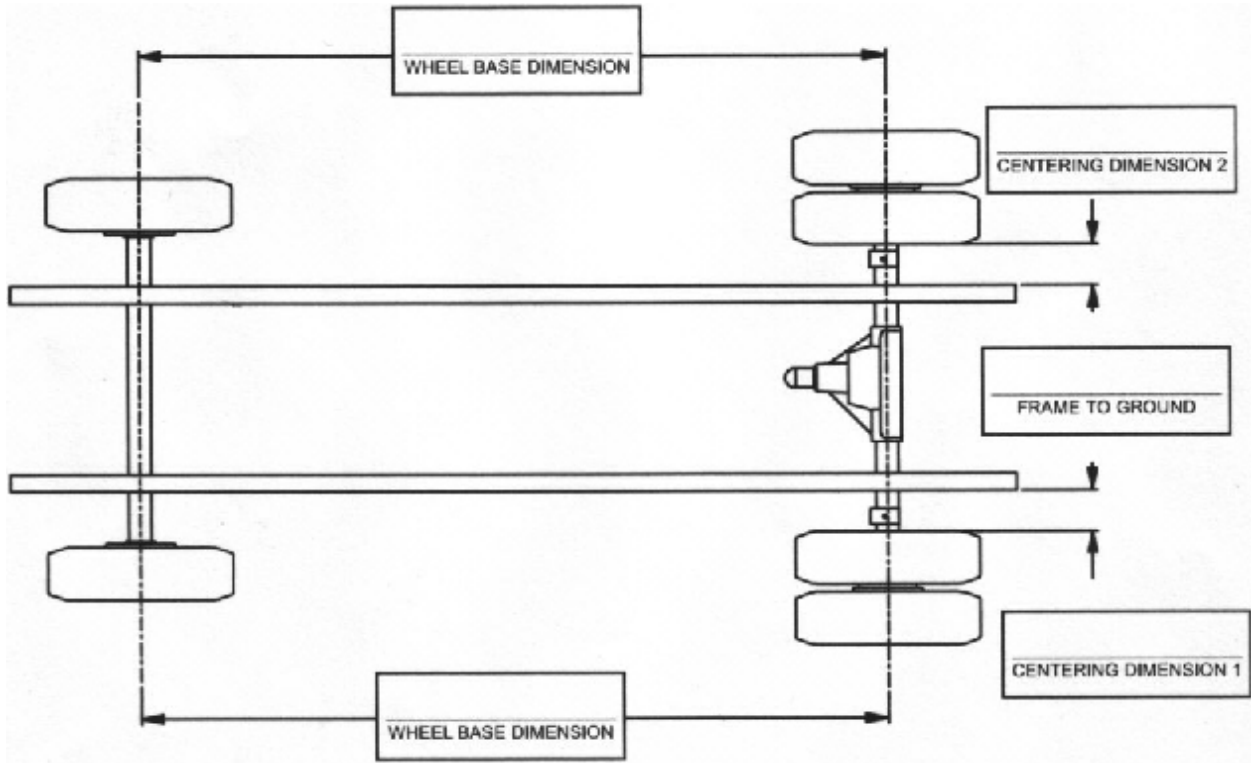

CHEVY 4500 SQUARE-AXLE OWNERS GUIDELINES

The Kelderman suspension needs no lubrication and little maintenance. However, immediate corrective action should be taken if a serious malfunction occurs.

CAUTION! If maintenance or service is to be done on the air system, be sure to drain all air from the system. Serious injury could occur if components are removed while system is full of air.

PRODUCT OWNER RESPONSIBILITIES

- Owner is solely responsible for pre-operation inspection, periodic inspections, maintenance, and use of the product as specified in the particular Kelderman MFG. instructions available by product model, except as provided in this warranty, and for maintenance of other vehicle components. Of particular importance is the re-torque of fasteners including axle bolts, four link bolts, and pan hard bar bolts. This re-torque must be performed within 90 days of the suspension being put into service.
- Owner is responsible for “down time” expenses, cargo damage, and all business costs and losses resulting from a warrantable failure.
- The Kelderman Air Suspension is fully automatic in controlling the height of the chassis. No manual intervention to control air pressure or ride height is needed during the course of operation.
- The Compressor Switch must be on for the compressor to operate. During difficult starting circumstances, (i.e. extremely cold weather) it is recommended to turn the compressor switch off until the vehicle is running, so it will not draw current from the battery. The compressor is controlled by the pressure switch located in the Air Control Box. This switch automatically turns the compressor on when the tank pressure falls below 110 psi, and turns them off at 145 psi.
- The Low Pressure Warning Light indicates a severe drop in tank pressure (below 45 psi). Immediate corrective action should be taken to determine the cause of air loss. Compressor switch should be turned off if Low Pressure Warning Light is on, and remains on even after the compressor has run for a normal period of time. **NOTE:** The Low Pressure Warning Light could come on briefly when the “Dump” feature is being used.
- It is important to release any moisture contained within the air tank on a daily basis. This is done by pulling on the attached release cable for approximately 5 seconds. Not releasing the moisture on a regular basis will cause the drain valve to not operate properly.

CHECK AT EVERY VEHICLE SERVICE INTERVAL:

Check Ride Height $\pm 1/4$ "

Check for air leaks around fittings.

CHECK AFTER THE FIRST 1000 MILES:

Recheck & tighten any loose fasteners.

Check for any loose or worn components.

CHECK AFTER EVERY 30,000 MILES:

Check trailing arm bushings and pan hard bar bushings for wear; replace if worn.

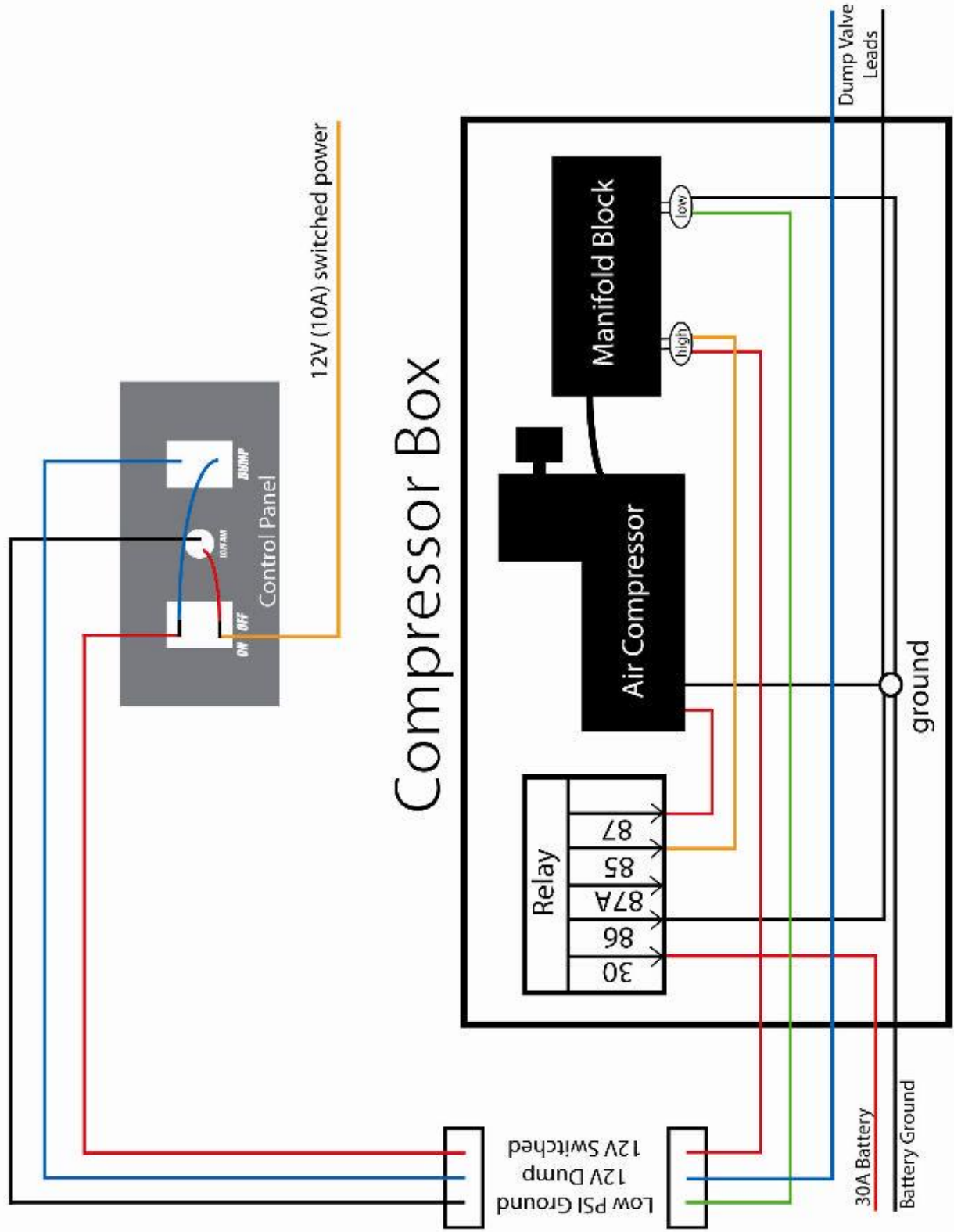

Compressor Box Self-Leveling Kit Wiring Diagram (shown with optional dump valve)

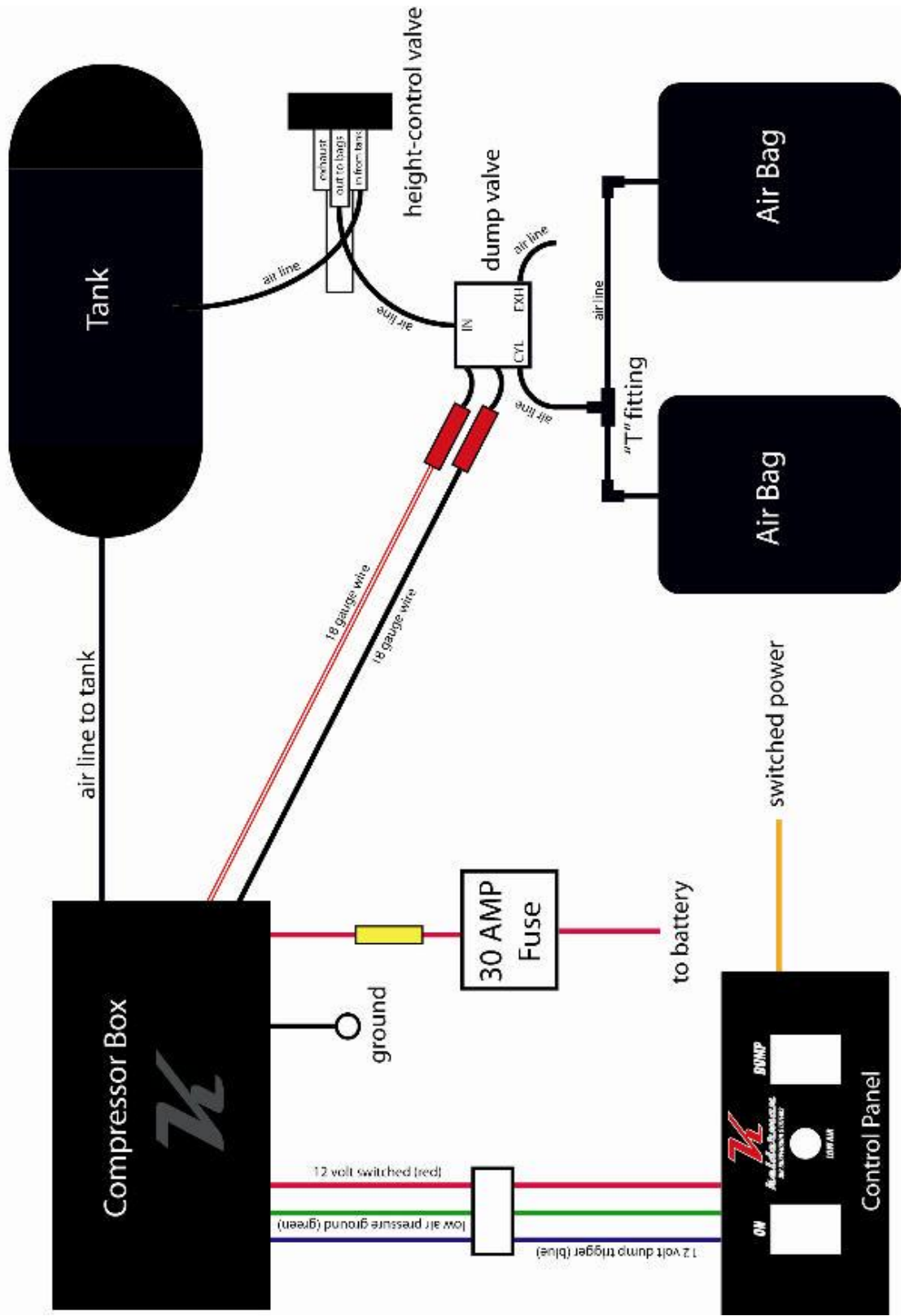

TROUBLE SHOOTING GUIDE

<u>COMPONENT</u>	<u>POSSIBLE PROBLEM</u>	<u>CORRECTIVE ACTION</u>
Air lines	Air leaks	Replace air line.
Fittings	Air leaks	Remove fitting and apply fresh joint compound. Reinstall fitting, but Do Not Over Tighten. Do not use Teflon tape.
Air Bags	A. Improper height B. Air leakage	A. Adjust valve linkage to maintain proper air spring height. B. Replace air bag.
Panhard Bar	A. Loose nuts on lateral control rod bolts. B. Worn bushings	A. Tighten securely. B. Replace lateral control rod.