



1-800-334-6150

info@kelderman.com

www.kelderman.com

2003-2013 RAM 2500/3500 4x4
4-Link Rear Installation Instructions
Stock Height-3" lift



1. Before you do anything, place the truck on a level surface and record the pinion angle here _____. If you have the ability to remove the bed, we would recommend doing so. Once the bed is off, remove the rear leaf springs, and rubber bump stops on the bottom of the frame. Keep the bolts from the leaf spring hangers. They will be re-used in the installation of the air suspension.



Use an angle finder to get pinion angle recorded off the bottom of the axle

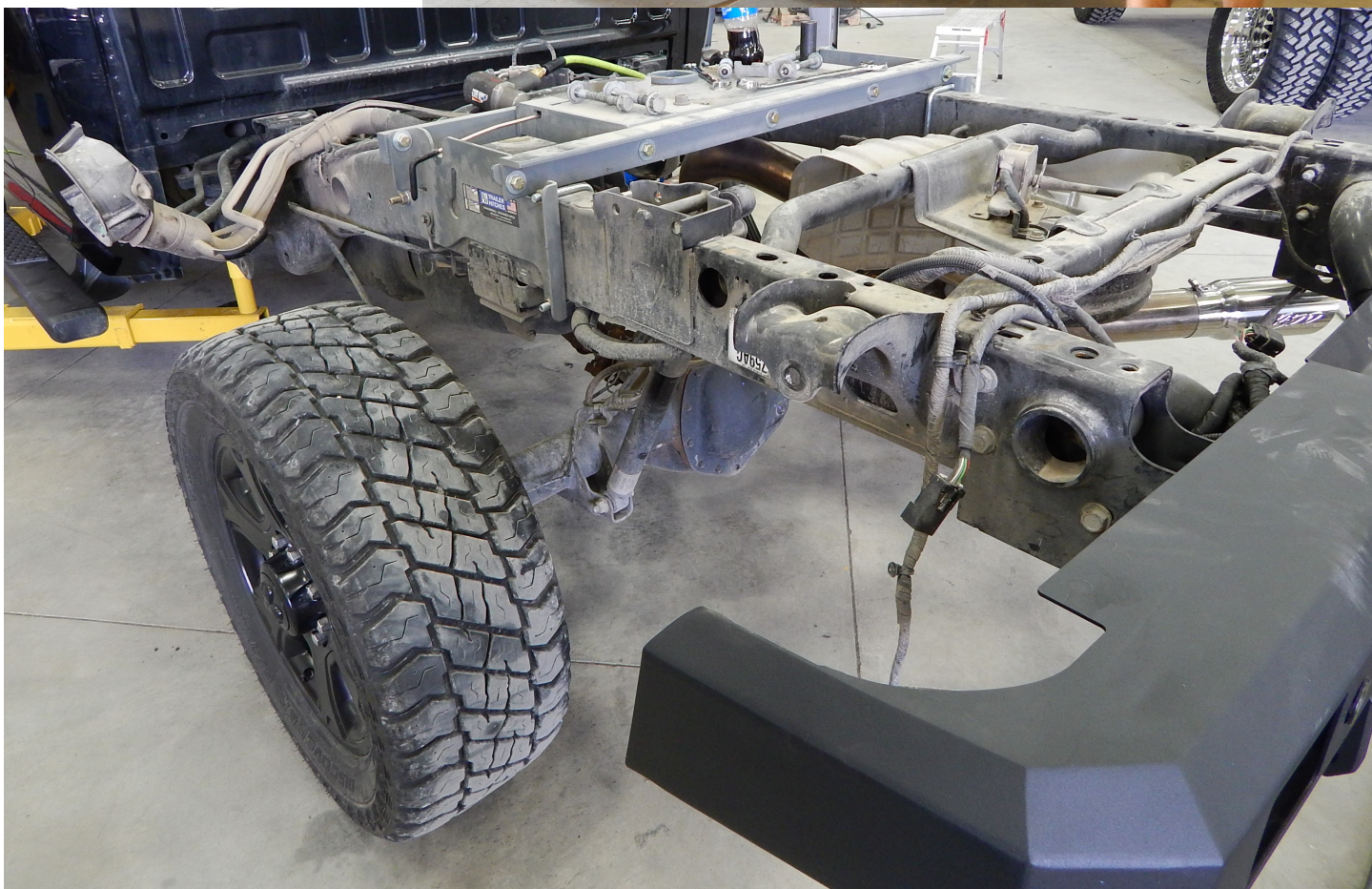

2. Locate the forward trailing arm mounts (part# 10070 DS and 1071 PS). They fasten to the forward leaf spring perches with the OEM bolts, 1/2 x 1 1/2" bolt & 1" bolt. Welding **will be required** to eliminate popping noises upon acceleration and braking. Torque the OEM bolt to 150 ft/lbs and the 1" bolt to 300 ft/lbs. Use the pictures below to see where to weld. NOTE: When welding unhook the batteries or use an electronics "anti-zapper" protection device on the batteries.



A small piece of 1/4" scrap metal was used to fill the gap here

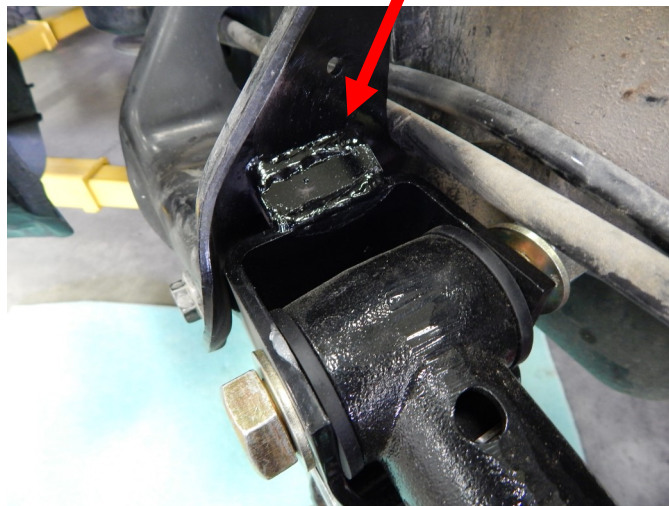
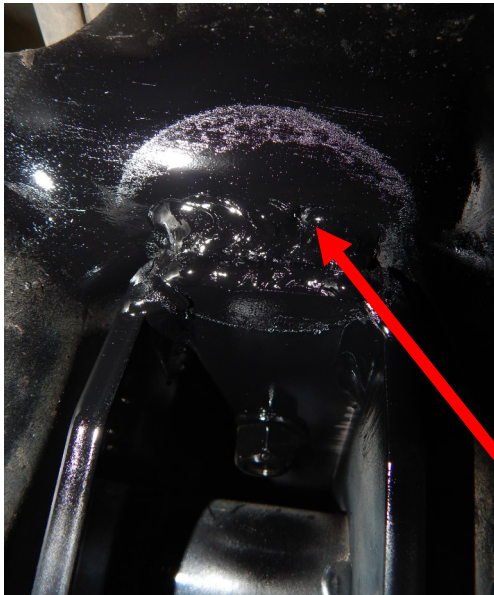

Weld under the front portion of the air ride bracket and !?!?!?



Place a 2" weld on the inside flange where the one inch bolt attaches on the inside of the trailing arm mount. Paint the welded area to avoid corrosion.

3. Remove the factory bump stop off the bottom of the frame rails. To keep the truck at factory ride height you will need to cut off the bump stop mounts. If a 2" lift is desired, leave the bump stops attached. The bottom of the frame is threaded. You will need to run a M10x1.50 tap through the threads to clean out the dirt and rust. Once the treads are cleaned up, locate the upper air bag mount and attach to the bottom of the frame with the M10x1.50x30mm metric bolts. The oval in the

upper bag mount goes towards the rear of the truck. Torque to 25 ft/lbs.

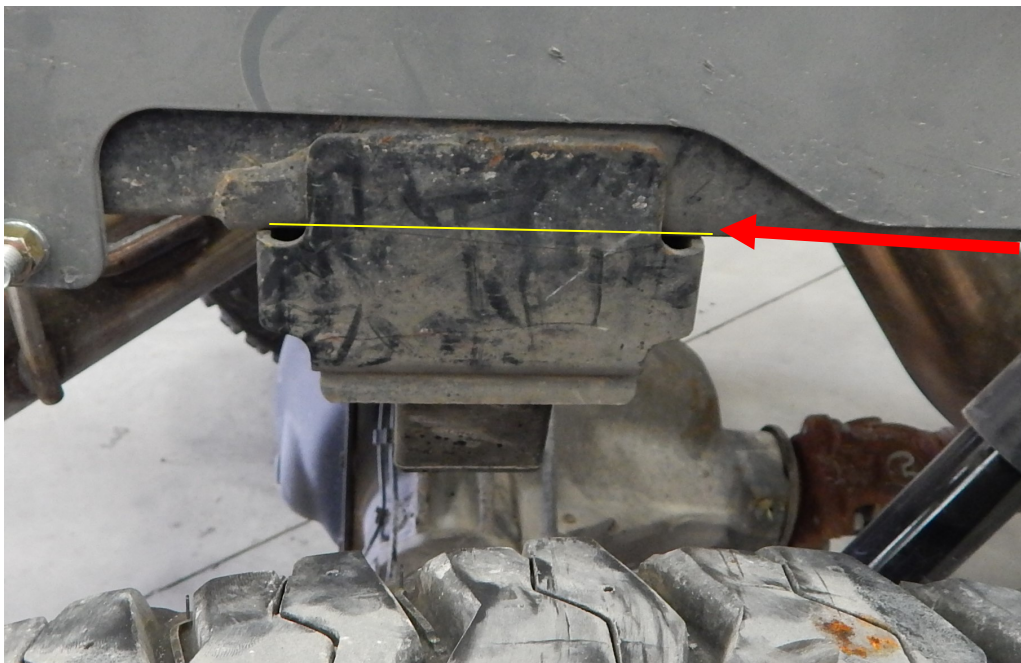

Cut the bracket off that holds the bump stop. Then use a grinder to remove the piece left on the outside of the frame.



Upper air bag mount installed. NOTE: if the truck has a B&W style hitch remove the side plates for extra room while working.

4. If the truck has a hitch installed, like a B&W style hitch, there will be a small amount of additional cutting and welding required. Locate the pan hard bar drop (part# 10314). The backing plate (part# 10315) of the pan hard bar fits on the outside of the frame. There is a cut out on the backing plate that goes around the cross member under the truck bed. You can identify the spot on the frame where this goes via the round hole in the rubber pad on top of the frame. The B&W hitch overlaps an inch or so. Overlap the backing plate on the B&W side plate with the notch in the side plate centered on the hole in the rubber pad. Mark the edge of the backing plate on the B&W side plate. Now remove the side plate. **NOTE: You will need to put a zip tie on the forward bolt on the B&W side plate before you remove the nut to keep that bolt from falling into the frame!**

Rubber pad on top of frame with hole in it

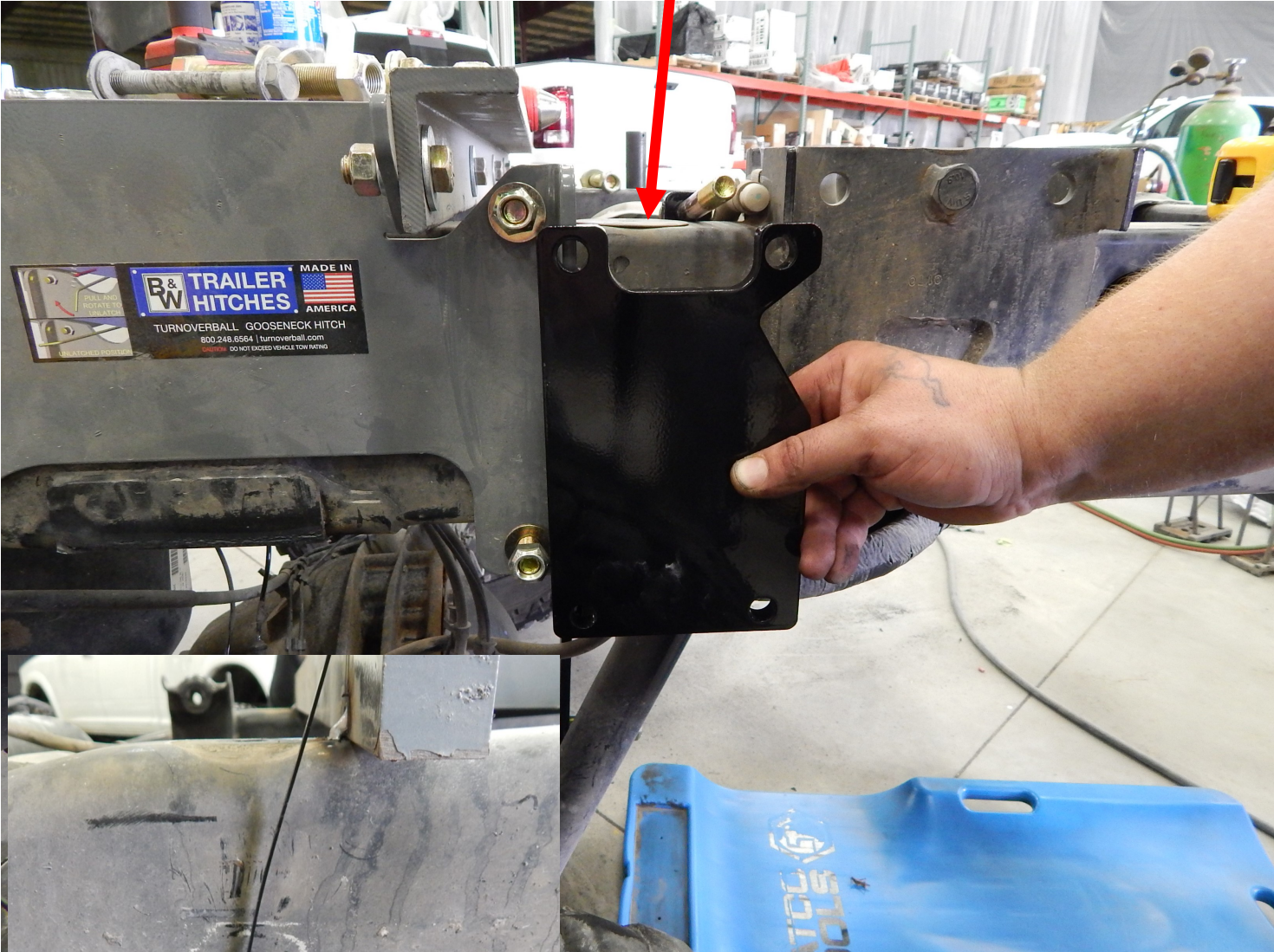

Forward bolt of B&W side plate with zip tie attached

5. Pictured below is what the B&W side plate looks like with the pan hard bar backing plate welded to it. This unit was painted black to match the air suspension. When fastening the pan hard bar drop to the frame, run the top bolts and front bottom bolts outside in. The lower rear bolt runs inside out. If this bolt isn't run outside in it will rub on the shock. If you are changing shocks, this is a good time to do it.



6. Locate the lower bag mounts (part# 11399DS and 11569PS) and axle clamps (part# 11663). Install them onto the leaf spring perches on top of the axle with the 5/8x8" bolts and clamp them to the axle with the axle clamps. Torque these bolts to 175 ft/lbs

Passenger side

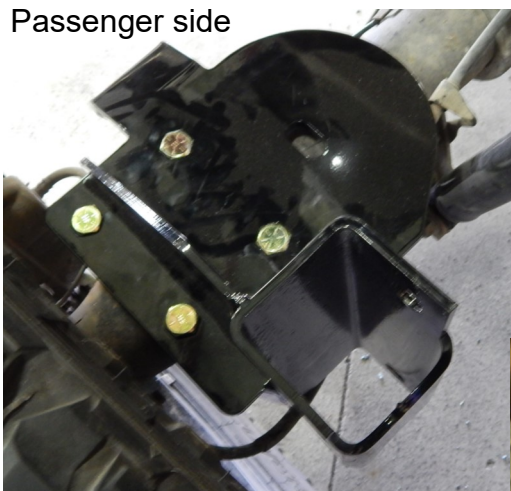

Pan hard bar drop

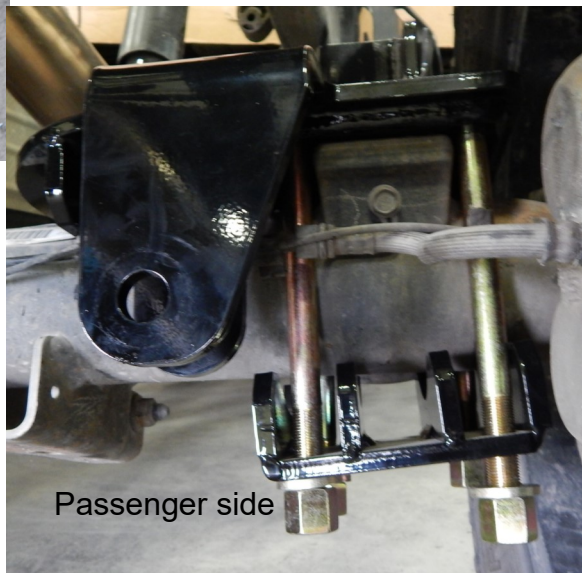
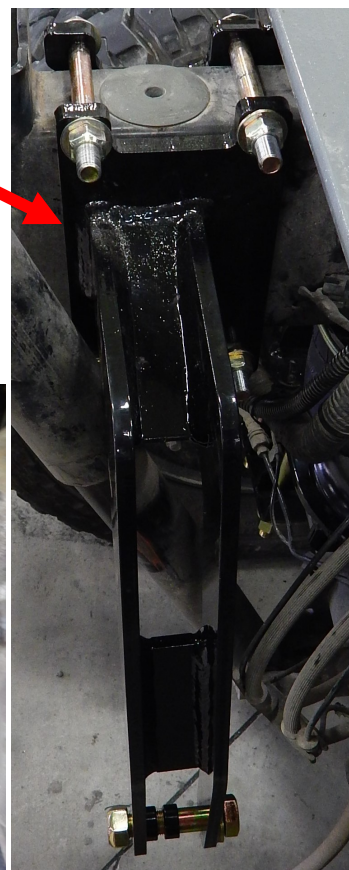

Passenger side

6. Locate the air bags (part# 5748). They will be installed in between the upper and lower air bag mounts. Examine the lower stud on the air bag and confirm that it measures 2" (with the base removed). At the factory, the lower 2 threads are cut off. If the lower threads are not cut off the air bag base (cone) will not sit flush on the lower air bag mount. Once that measurement is confirmed, drop the bag in place (with the cone on the bottom). Use the 3/4" nut and lock washer to fasten the bottom of the bag. Torque this to 35 ft/lbs. The top fastens with one 3/8"x1" nut. Use the flat washer and lock washer. Torque this bolt to 30 ft/lbs. Make sure the large port is in the large oval on the air bag mount. Now locate the 90 degree fitting and insert it into the air port. Make sure the air fitting is pointed towards the rear of the truck. Tighten to 25 ft/lbs. Once the install is complete, you will need to come back and check for air leaks with soapy water or gas leak detector.



7. Locate the trailing arms (part# 10016). Set 2 of the trailing arms so there is 9 3/16" between the knuckles (these will be the bottom) and set the other 2 with 8 1/4" between the knuckles (these will be the top) This is a good place to start to have the axle centered and the pinion angle close to the correct setting. You will still need to fine tune it once the install is complete. Insert the 7/8x 5 front bolts from the outside in. The lower 7/8x5" bolt on the rear can go inside out. The top 7/8x5" bolt on the rear must go outside in. The wheel will have to be removed to insert this bolt that direction. If the upper rear bolt is not installed the right direction it will rub on the inside of the tire. Do not torque the 7/8" bolts yet. This will be done in step 12.



The orientation of this bolt is critical. Make sure it isn't rubbing on the tire if wider tires are on the vehicle.



8. Locate the accumulator tanks (part# 18485). These fit in the rear leaf spring hanger. Use the factory bolt that held the leaf spring shackle in place. Make sure the tank has the large port facing the front of the truck. Torque the factory bolt 100 ft/lbs. Next, insert the 3/4" 90 degree air fitting in the top of the air bag. Make sure that the fitting is facing the rear of the truck after tightening. Now locate the provided 5' section of 3/4" air line. Place it next to the air fittings and cut it down to fit. Make sure to leave yourself an extra inch longer than you think you will need. The 3/4" air line is not very flexible so it needs to be longer than you think.

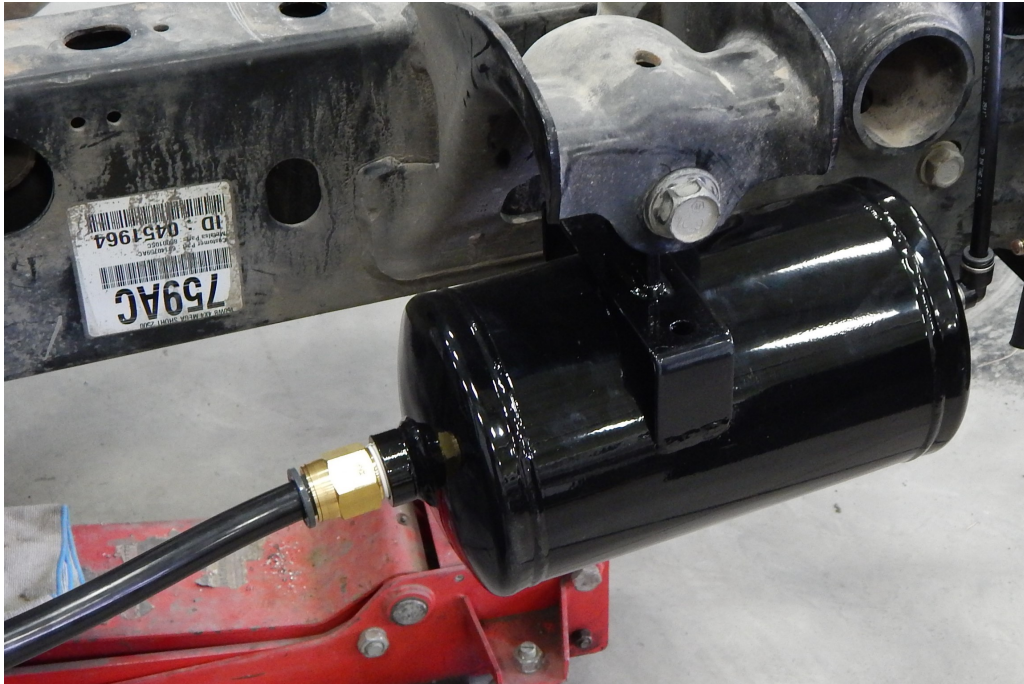

9. Locate the pan hard bar (part# 11578) and the 4 spacers. Use the 3/4x4" bolts to fasten the pan hard bar in place, using the spacers to center up the heim ends. Torque these bolts to 175 ft/lbs.
10. Locate the sway bar mounts (part#18322 and or 14819), end links (part#18488) and sway bar (part#1129-125KLD). Locate the blue bushings for the sway bar, apply the supplied grease inside the bushings and place over the sway bar. Next place the "D" rings over the rings over the blue bushings and attach to the shock mounts on the bottom of the axle with the 7/16x1" bolts. Torque these bolts to 45 ft/lbs.
11. There are 3 ways to attach the sway bar end links to the frame.

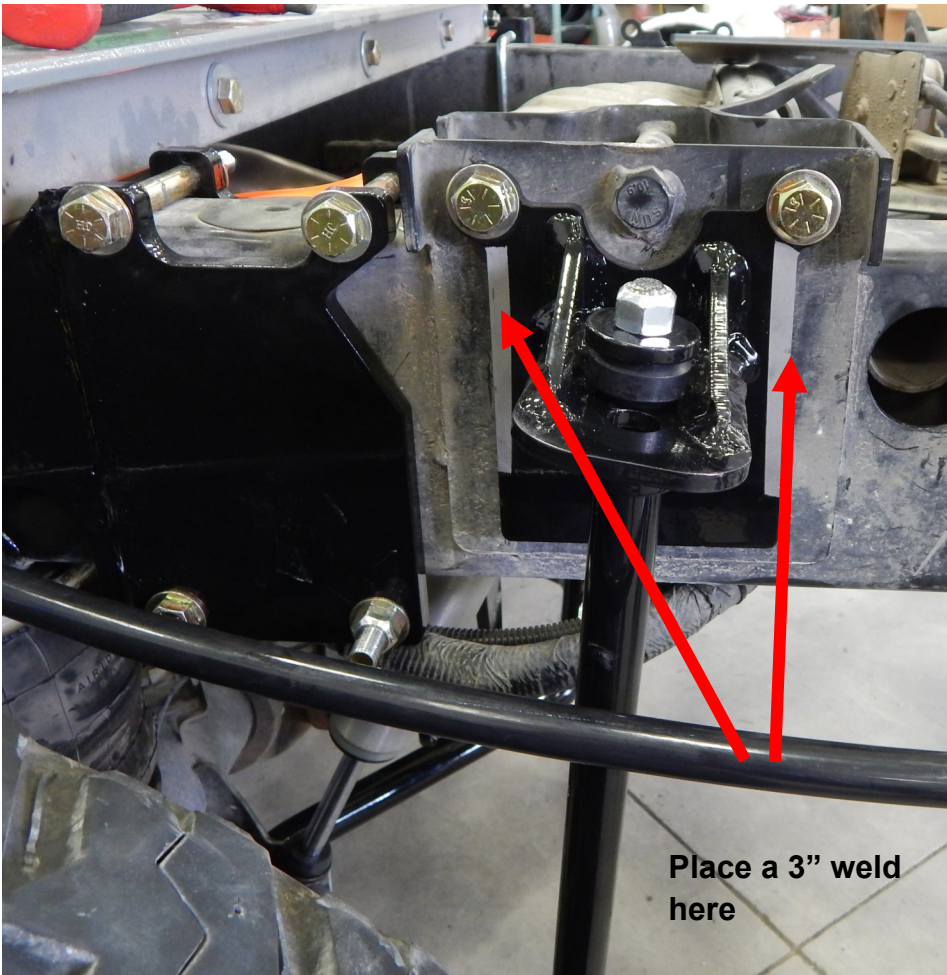

- If you have a truck with factory overload pads, remove the rubber pad and drill out the hole so the stud end of the end link. You will want to oblong his hole forward and back so the end link stud has room to move as the truck goes up and down. **See pictures on page 11.**

-Use the mounts shown in the picture to the left. They bolt to the brackets on the side of the frame with the 1/2x 1 1/2" bolts. You will also put a 3" weld on each side of the end link mount.

-The last end link mount is the style that clamps to the frame (part# 14819&11102). Use the XX x XX bolts to sandwich the mounts over the frame.

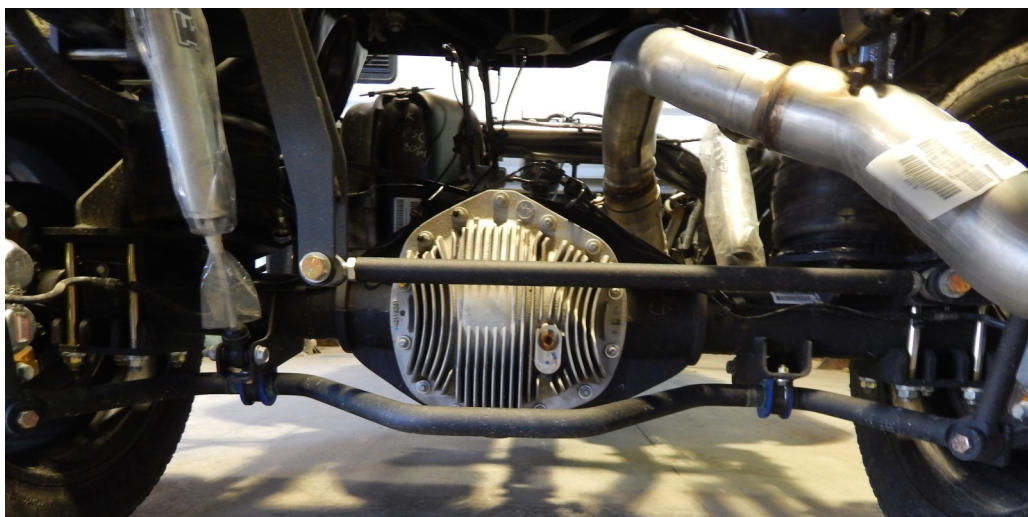

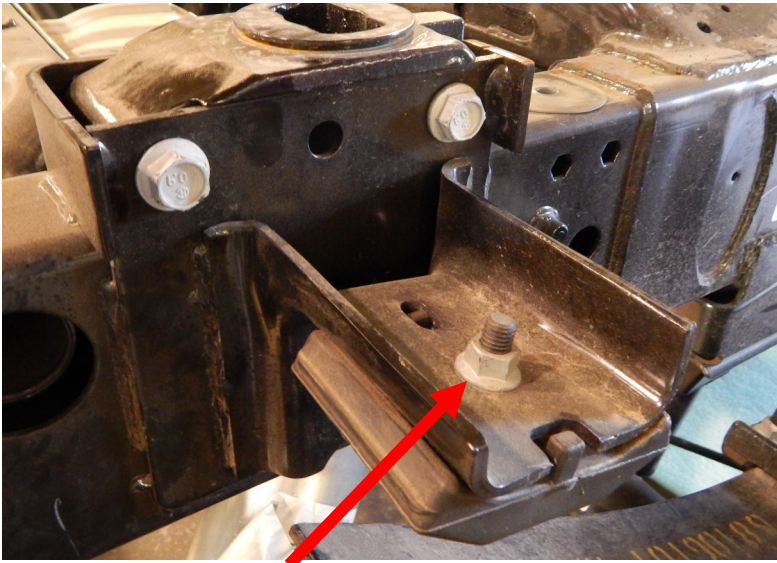

Remove the factory pad and drill out the for the end link stud. Move the drill bit for and aft to provide room for the end link to move

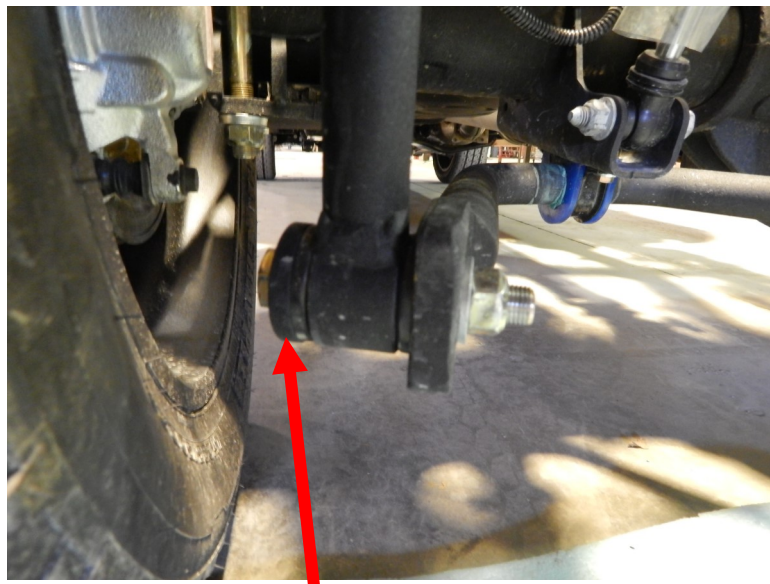

Lower end of the end link fastens to the sway bar with the 1/2x3" bolt. Make sure to use the large flat washer on the outside where the rubber bushing is.



Installation completed torque the nut so the bushings swish, but don't completely flatten the bushings

11. Now that the install is complete, its time to install the controls and do the final set up on the kit. There are two different control systems offered. Once is a mechanical system that uses Haldex height control valves. These are the same valves used on semi trucks and trailers. The other style is an electronic system. The sensors/height control valves mount to the bracket on the trailing arm mount. Locate the collar that clamps to the upper trailing arm and the linkage that connects the two. You will need to set the air bag ride height at 7 1/2”.

Mechanical controls shown below

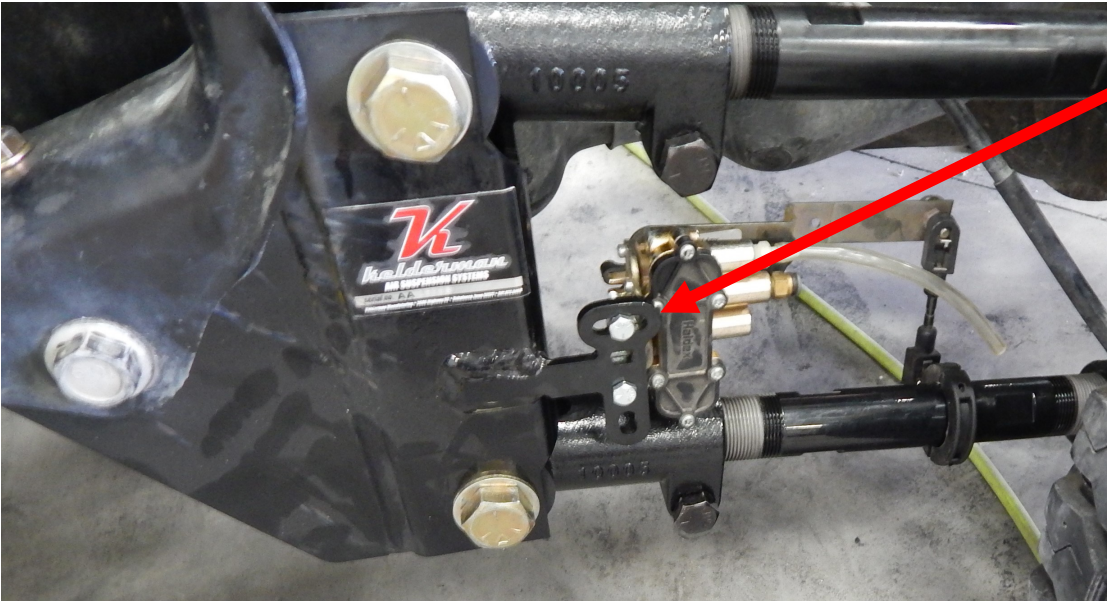

The top mounting hole is slotted allowing for fine tune adjustments.

Electronic sensor pictured below

12. Now that the bags are at 7 1/2”, place a jack stand under each side of the frame (or under the rear hitch). Let the air out of the air bags. Now you will want to set the pinion angle to your measurement recorded in step one. Shortening the top bars raises up the pinion. The axle should be fairly close to being centered in the wheel well. Next, with the help of another person, measure the distance between the axles. We want that to be within 1/8” of each other on each side.

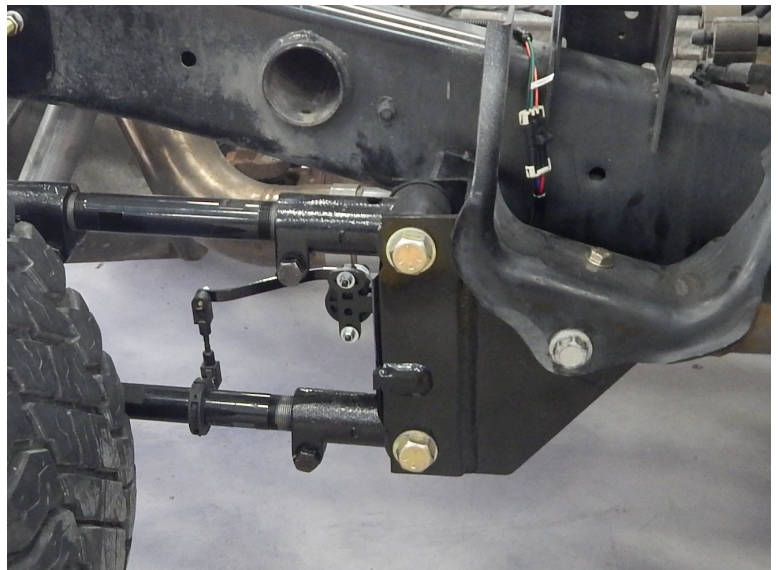

13. The best way to square up the axles is to measure from the front housing of the rear axle to the kingpin ball joint. Measure out each side and adjust the trailing arms to get the same measurement. When turning the trailing arms, we recommend turning each one half a turn at a time. Going full turns will bind the arms up and make the adjustment more complicated. Once the axles are centered, pinion angle set, center the axle with the pan hard bar. Once all this is done, tighten the 7/8” trailing arm bolts to 300 ft/lbs and the 5/8” clamp bolts in the knuckles to 100 ft/lbs. Now double check to make sure all the bolts are torqued on the entire kit.

13. The air tank and control box can be mounted anywhere on the truck. A popular spot is on the inside or outside of the frame on the drivers side. This is the first choice since it is opposite of the exhaust. The best option is to drill and tap the frame in order to mount the control package. You may mount this air control system in any location as long as you have an adequate amount of air line and/or wiring.

Friday, October 2, 2015 11:46:11 AM

ITEM NO.	PART NUMBER	DESCRIPTION	QTY.
1	11569	Lower Bag Mount (PS)	1
2	11399	(DS) Lower Bag Mount	1
3	10016	20-22" Trailing Arm	4
4	11578	Pan Hard Bar	1
5	10071-G4	MOUNT - FRONT PERCH (DS)	1
6	10070-G4	MOUNT - FRONT PERCH (PS)	1
7	10314	(PHB) Mounting Bracket	1
8	15738	Upper Bag Plate	2
9	22002	Upper Bag Mount (5th Wheel Mount)	1
10	22003	Upper Bag Mount (5th Wheel Mount)	1
11	10315	(PHB) Frame/Ear Mounting Plate	1
12	5748	5748 Firestone Air Bag	2
13	11663	CLAMP - LOWER AXLE 4" STD	2
14	14819	Upper End Link Mount	2
15	18488	19" End Link (Dodge Style)	2
16	11102	End Link Mount Pinch Plate	2
17	18321	(DS) Sway Bar Frame Mount	1
18	18322	(PS) Sway Bar Frame Mount	1
19	18485	Dodge Tank	2

UNLESS OTHERWISE SPECIFIED:		Design By: Zach Beltz 2014	Project: 2010-2013 Dodge G4 Stock Height (Rear)
DIMENSIONS ARE IN INCHES TOLERANCES:		Shell # / Qty	Description: KB
FRACTIONAL: 1/32"		Inventory	SIZE DWG. NO.
ANGULAR: MACH: 1 BEND: 1		Run Qty:	A D4R4-23-X-10
TWO PLACE DECIMAL ±.030		SCALE: 1:50 DO NOT SCALE DRAWING	
THREE PLACE DECIMAL ±.009		SHEET 1 OF 2	
MATERIAL		PROPRIETARY AND CONFIDENTIAL	
FINISH		THE INFORMATION CONTAINED IN THIS DRAWING IS THE SOLE PROPERTY OF KEELDERMAN MFG. INC. ANY REPRODUCTION IN ANY MANNER WITHOUT PERMISSION FROM KEELDERMAN MFG. INC. IS PROHIBITED.	
WEIGHT		485.5121	

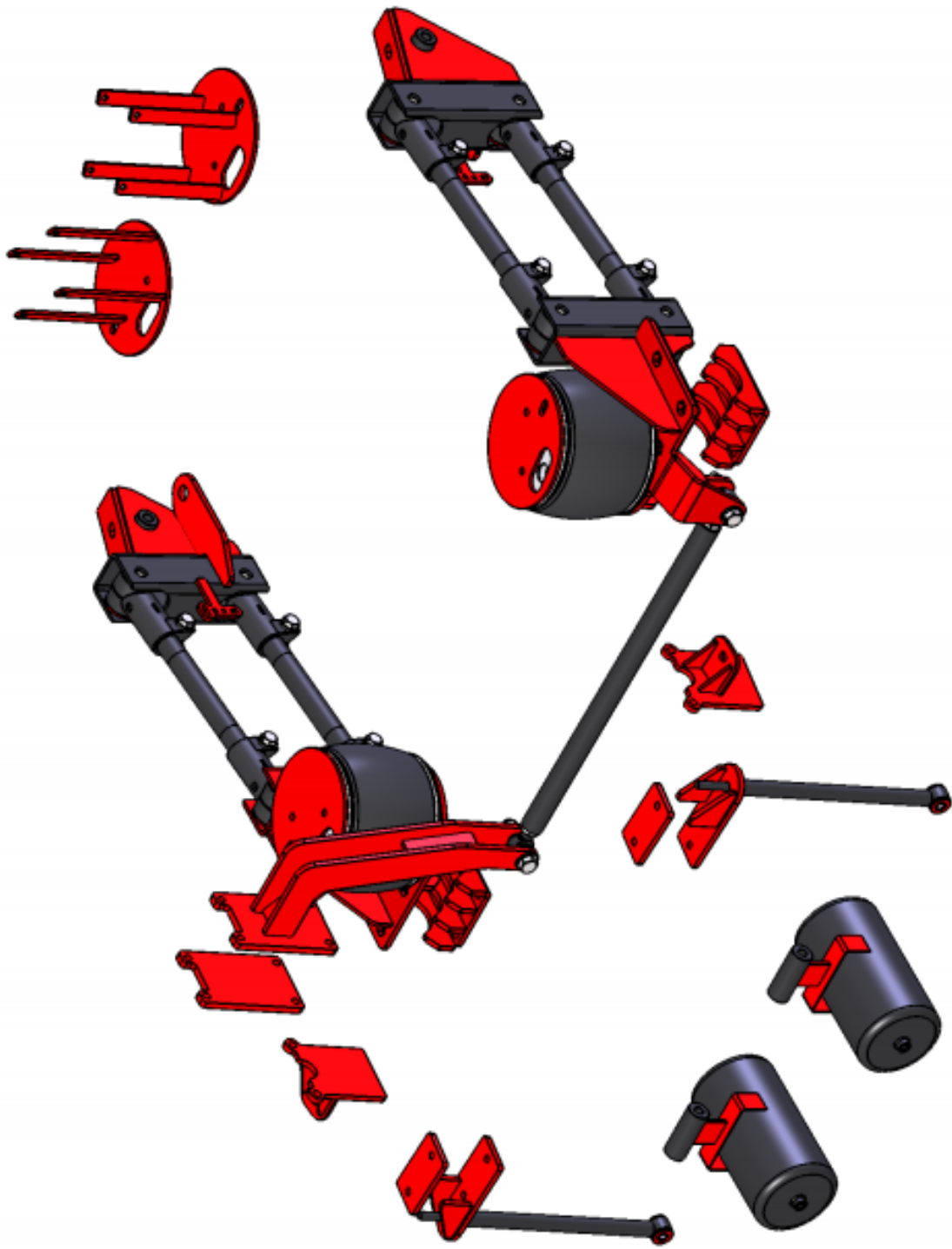

Compressor Box Self-Leveling Kit Wiring Diagram (ambulance prep package)

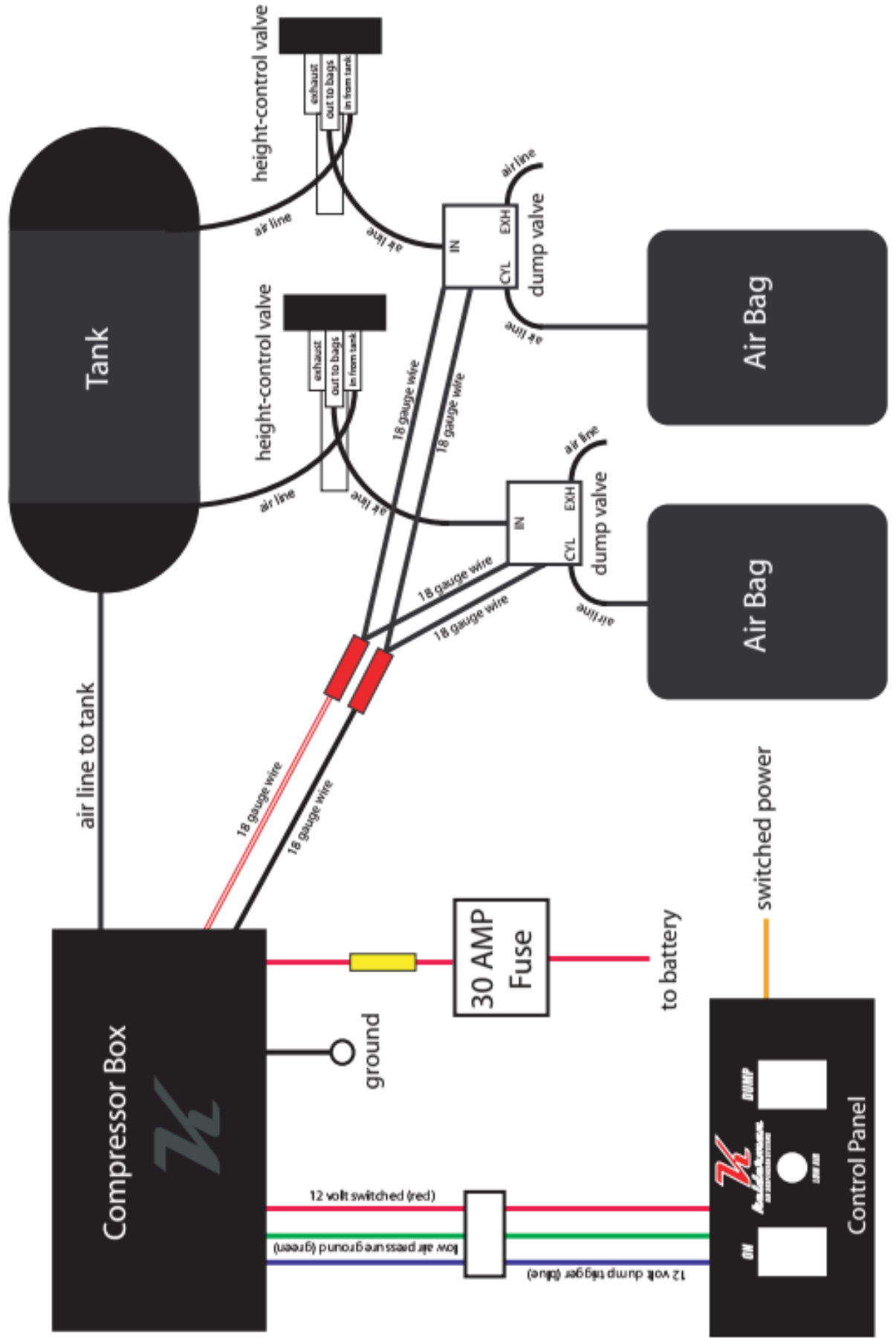

Mechanical Dryer Wiring Diagram

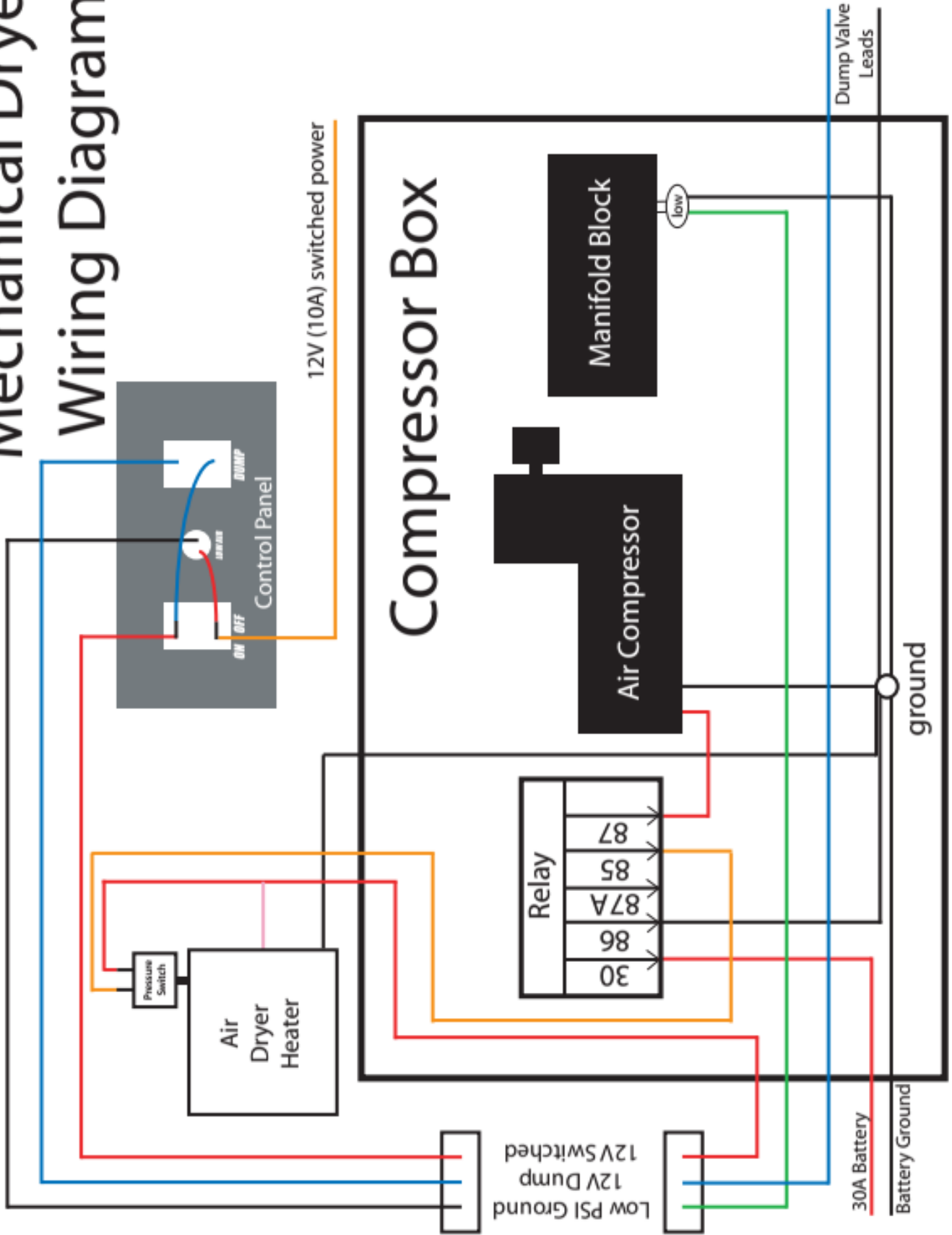

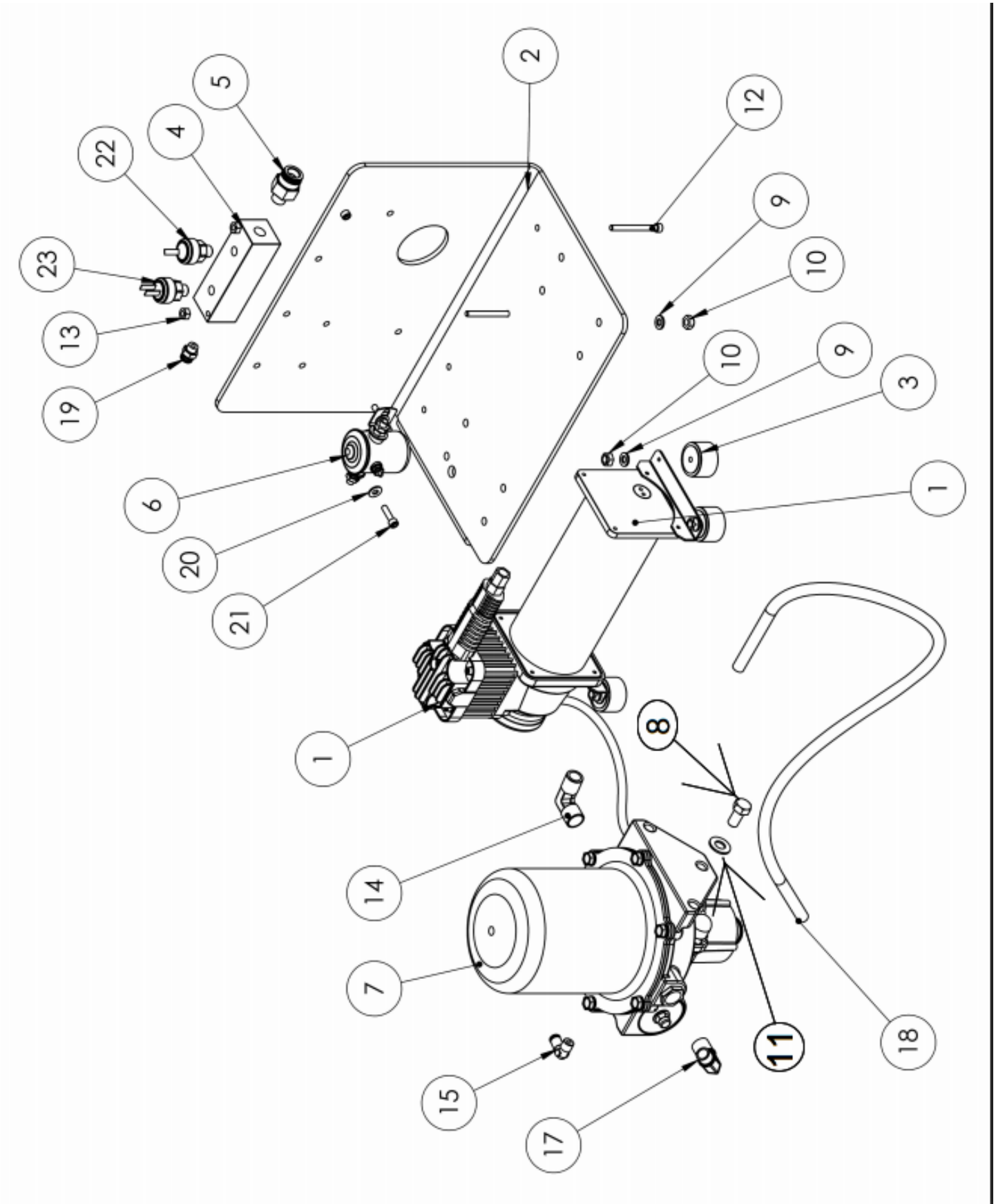

SLKD2WD AIR CONTROL SYSTEM

SLKD2 Parts Breakdown

ITEM	PART NUMBER	DESCRIPTION	QTY.
1	COM 444VIAIR	444C Compressor	1
2	15137	Compressor mounting plate	1
3	2NPA5	Compressor feet	4
4		Manifold block	1
5	KV2H11-34S	3/8" tube to 1/8" pipe straight	1
6	XA 210846 Tekonsha	S. Tekonsha Relay	1
7	Air Dryer - DU4	Mechanical air dryer	1
8		HBOLT 0.3750-16x0.75x.75-N	3
9	Washer, Lock-1/4	1/4" Lock Washer	8
10	Nut,Lock Insert 1/4-20	Nylon Insert Lock Nut - 1/4-20 Zinc	8
11		Preferred Narrow FW .375	3
12	Bolt-10-32x2 SOC CAP	10-32x2 Socket Head Cap Screw	2
13	Nut,Lock Insert 10-32	Nylon Insert Lock Nut - 10-32 Zinc	5
14		1/2"x3/8" Swivel	1
15	Fitting - 1/4x1/4 90deg Elbow	1/4 x 1/4 Elbow	1
16	Dryer Fitting - 1/2x3/8 Hex Bus	1/2 to 3/8 Reducer	2
17	Fitting - 3/8x1/4 90deg Elbow	1/4" x 3/8" Elbow male/male	1
18	COM braided hose	Viair Braided Hose	1
19	KV2H07-35S	1/4" tube to 1/4" pipe straight	1
20	Washer, Lock-1/4	1/4" Lock Washer	2
21	Nut,Hex Finish-1/4-20 GR5	Hex Finish Nut - 1/4-20 GR5	3
22	PS15 STI	Low Pressure Sensor	1
23	PS 90101	High Pressure Sensor	1

SLKD2WD AIR CONTROL SYSTEM