

10004488 (19+)  
KLM21525 (16-18)



**VERSION 1.2**

A 17/64" drill bit is required.

A 5/16-18 tap and 1/4" and 13/64" drill bit is required if installing height control sensors or valves

**2686 Highway 92 - Oskaloosa, IA 52577**  
**phone: 641.673.5396**  
**www.kelderman.com**

# **2019+/2016-2018 Ram 4500/5500 2-Stage Front Air Suspension Installation Instructions**

---



1. *These instructions work for 2019+ RAM 4500/5500 Kits (# 1004488) and 2016-2018 RAM 4500/5500 Kits (Part # KLM21525).* Jack the truck up by the frame and remove the tires. You will need a couple of floor jacks under the front axle to keep the axle from dropping when you remove the shock. We will install the drivers side first. The passenger side mounts exactly the same but does not have anything above the shock mount. If two people are doing the install both sides can be done at once.

2. Remove the plastic inner fender liner. Remove the nut from the sway bar end link and remove the shocks. Drop the jacks that are holding the axle up until the tension is off the coil springs.



3. On the drivers side, cut the rear tab off the ABS motor mount. It will interfere with the upper shock mount. The bracket will now be held in place with just the front bolt.

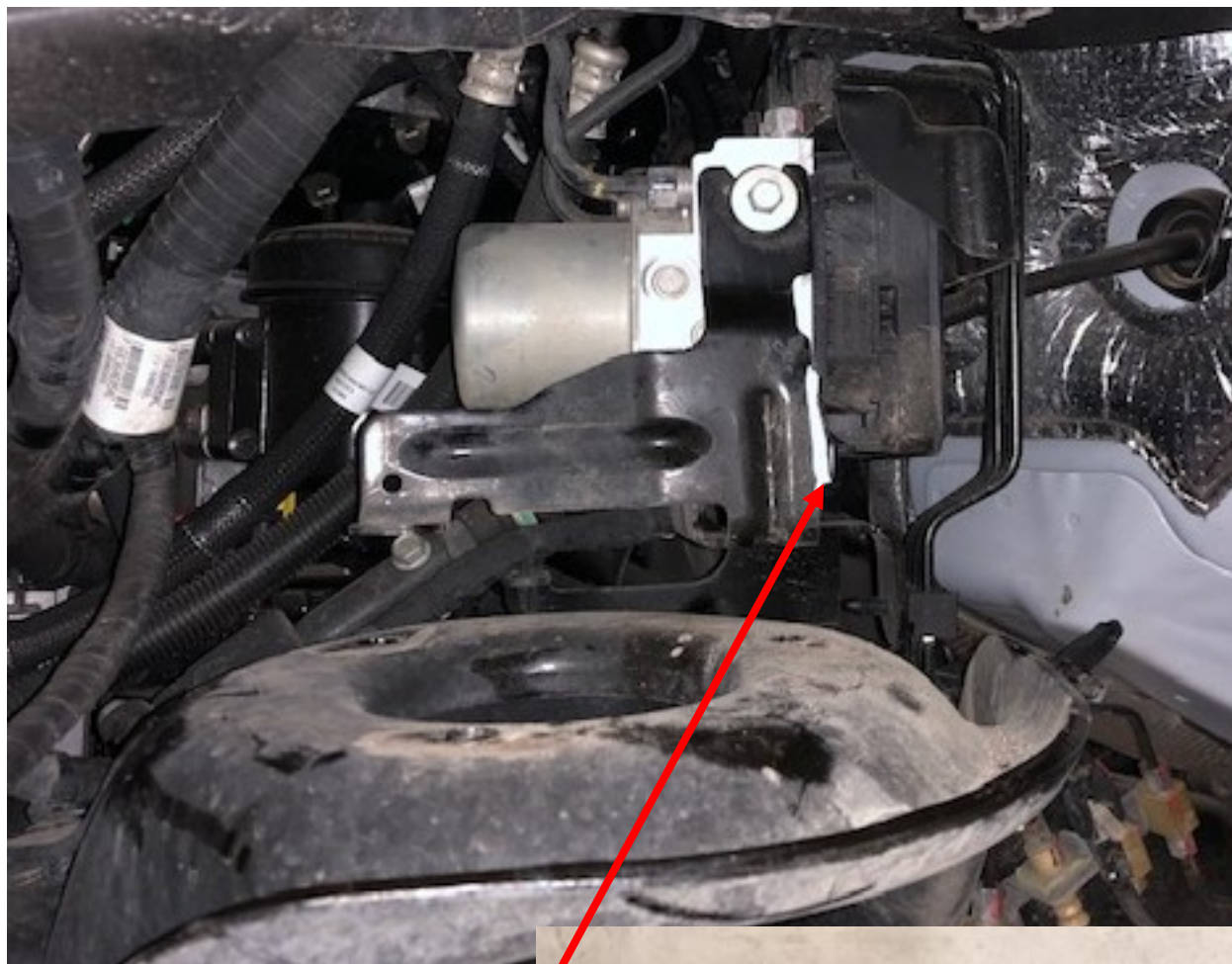

This tab needs to be cut off the mount



4. Locate the lower air bag mount (Part # DS21528 and PS21531) and air bag (80012-5323). The air bag fastens to the lower air bag with the 1/2 x 3 3/4" bolt. The air bag must be indexed 180 degrees off with the mounting tab on the bottom of the air bag. Torque the 1/2" bolt to 35 ft./lbs. Do not mount this assembly yet. It gets installed after the upper bag mount and shock mount.

*The upper studs and the lower mount need to be 180 degrees from each other*



5. Locate the upper bag mount (Part # DS21527 and PS21530 and upper shock mount (Part # DS21526 and PS21529). Insert the upper bag mount into the factory spring perch with the air port facing out away from the frame (towards the tire). Slide the upper shock mount over the 3/8" studs on the upper bag mount. Starting with the nut closest to you, fasten the two parts together with the 3/8" lock washer and nut. Snug this up tight. Slide the ABS front bracket down on the inside front 3/8" stud. Install the last two 3/8" lock washers and nuts. Torque all three nuts to 35 ft./lbs.



6. Drop the lower bag mount/air bag assembly into the lower spring perch. The lower bag mount fastens in place with the lower shock bolt and factory nut that has the tab on it. Torque this bolt to 125 ft./lbs.



Lower air bag mount fastens into the axle with the factory lower shock bolt



7. Jack the axle up so the air bag studs slide up into the upper air bag mount. Use the 1/2" and 3/4" lock washers and nuts to fasten the air bag to the upper bag mount. Torque these nuts to 35 ft./lbs.





8. Locate the Rancho shocks (Part # 80096/RS99113 and four shock spacers (Part # 11565). The shocks are a 9 way adjustable shock. Set the dial to setting 3. That has proven to be the best valving to work with the air bag. Use the 1/2" x 4 1/2" bolts and spacers to install the top of the shock to the shock mount. Use the 1/2 x 3" bolt on the bottom. Torque the shock bolts to 65 ft./lbs.

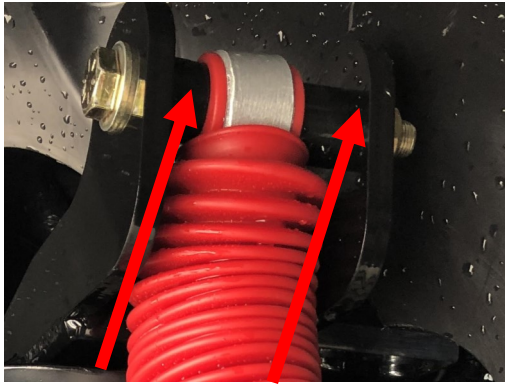

*One spacer on each side*

*Adjustment knob*

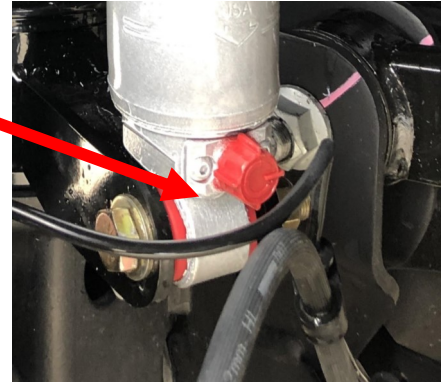

## Plumbing The Air Bags.

The best ride for the air bag is between 7.5-8.5". When measuring the air bag, measure between the upper and lower mounting brackets.

There are three options for air controls. Manual fill, Mechanical valves, and Electronic Sensors

1. **Manual fill.** If you are not running any onboard air controls on the truck, simply air up the air bags with the supplied Schrader valves. You will insert the air fitting in the air port and tighten it finger tight, then one full turn after that. Determine where you want to place your Schrader valves. Under the hood or right off the air bag are popular choices. Once you have decided on the Schrader valve placement, cut the air line to fit between the valve and the air bag fitting. Use a razor blade and cut the air line so it's straight and clean. Push the air lines into the fittings. Alternate sides when filling the air bags. *Inflating one bag completely without alternating will result in the first bag becoming taller and require more adjustments.* Typical pressures on this system will be around 65-75 psi. Both sides should end up being within 5-10 pounds of each other.. ***Pressure in the system can vary depending on weight, application, etc.***



2. **Mechanical and Electronic:** The electronic sensors and mechanical valves fasten to a sensor mount with 1/4" x 1" bolts. The sensor mount must be welded on the inside of the frame. The best spot for the mount is just in front of the factory lower trailing arm mount. Weld the sensor bracket so the upper hole is 1/2" below the frame.

*Weld the sensor mounting tab just in front of the lower trailing arm mounting bracket*



*Linkage pictured is 4 1/2" long*

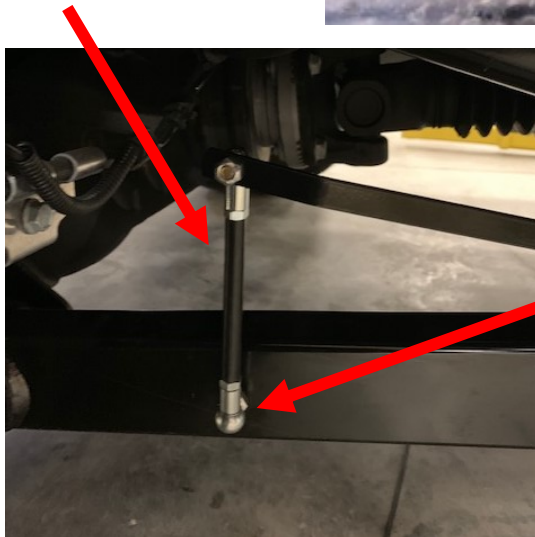

Drill a 17/64" hole in the lower trailing arm and tap with a 5/16-18 tap. The ball stud will thread here. When the air bag is at 8"/ride height, and the sensor arm is straight out, measure center to center on the ball studs (it should be around 4 1/2"). Cut the linkage to that dimension. The female end of the ball stud mount has a clip, that needs to be pulled to remove the linkage. *You cannot pull the linkage off without pulling the locking clip.*

The height control valve mounting tab is welded on the inside of the frame just in front of the lower OEM trailing arm mounting assembly. When the airbag is inflated to 8"/ride height, and the height control valve is straight out, go straight down and drill and tap the ball stud into the upper trailing arm

Fine tuning of the mechanical arm can be done by loosening the nut on the arm and raising or lowering the arm on the valve. Once the truck ride height is set tighten the nut back up.



*4 1/2" linkage pictured*

ITEM NO.	PART NUMBER	DESCRIPTION	QTY.
1	21 526	Weldment - (DS) Upper Shock Bracket	1
2	21 527	Weldment - (DS) 3.75" Bog Riser	1
3	21 529	Weldment - (PS) Upper Shock Bracket	1
4	21 530	Weldment - (PS) 3.75" Bog Riser	1
5	10005049	Weldment - (DS) Lower Axle/Bog Mount	1
6	10005048	Weldment - (PS) Lower Axle/Bog Mount	1
7	11 565	CRR - Shock Spacer - 1.00" OD x .51" ID x .75" Long	4
8	12021	Boil - 1/2" x 20 x 3" Gr.8 YZ	2
9	12033	Boil - 1/2" x 20 x 4 1/2" Gr.8	2
10	13046	Spill Lock Washer - 3/8" - YZ	6
11	13024	Washer - 1/2" Flat SAE Washer	8
12	13162	Hex Nut - 3/8"-20 Gr. 8 YZ	6
13	13164	Hex Nut - 1/2"-20 Gr.8 YZ	4
14	80012-5323	Purchased Parts - Firestone 5323	2
15	80096	Rancho RS999113	2

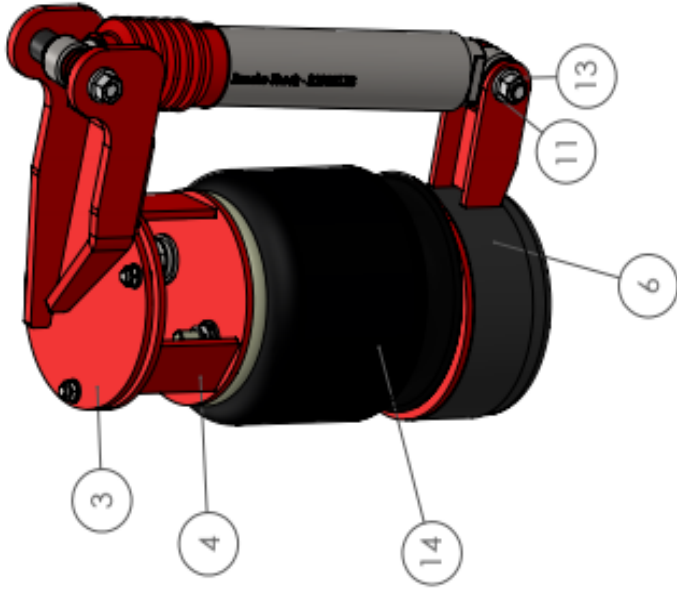
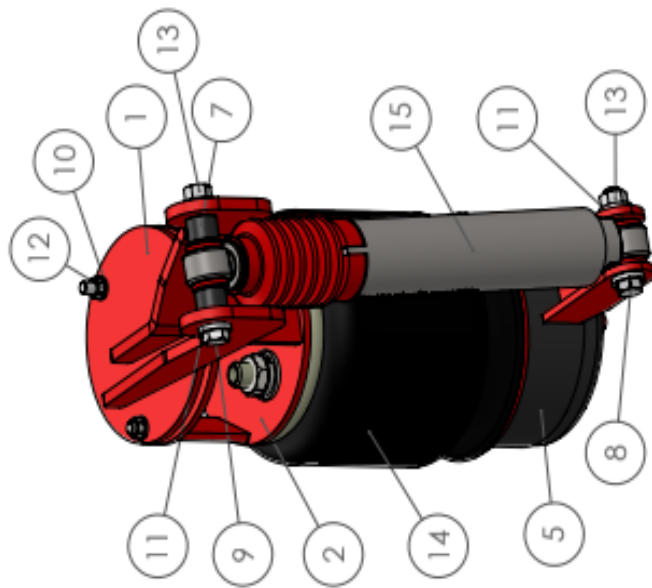

REV	ECN	CHANGE DESCRIPTION	ISSUED BY	DATE

MATERIAL SPECIFICATION	A	FOR NOT SPECIFYING	1:50	Approximate Weight = lbs
UNLESS OTHERWISE SPECIFIED, ALL DIMENSIONS SHALL BE IN INCHES.				
TOLERANCES UNLESS OTHERWISE SPECIFIED:				
FRACTIONS: 1/16" ± .005, 1/32" ± .005, 1/8" ± .005, 3/16" ± .005, 1/4" ± .005				
DECIMALS: .0005 ± .0005, .001 ± .0005, .002 ± .0005, .003 ± .0005, .005 ± .0005, .010 ± .0010, .015 ± .0010, .020 ± .0010, .030 ± .0010, .040 ± .0010, .050 ± .0010, .060 ± .0010, .070 ± .0010, .080 ± .0010, .090 ± .0010, .100 ± .0010, .125 ± .0010, .150 ± .0010, .175 ± .0010, .200 ± .0010, .250 ± .0010, .300 ± .0010, .375 ± .0010, .500 ± .0010, .625 ± .0010, .750 ± .0010, .875 ± .0010, 1.000 ± .0010, 1.250 ± .0010, 1.500 ± .0010, 1.750 ± .0010, 2.000 ± .0010, 2.500 ± .0010, 3.000 ± .0010, 3.750 ± .0010, 4.500 ± .0010, 5.000 ± .0010, 6.000 ± .0010, 7.000 ± .0010, 8.000 ± .0010, 9.000 ± .0010, 10.000 ± .0010				
PROJECT: 2019 Ram 4500-5500 Chassis Cab				
PART NUMBER: 10004488				
DATE: 7/19/2019				

SHEET 1 OF 3