

ITEM NO.	PART NUMBER	DESCRIPTION	QTY.
1	69421	Panhard Bar Crossmember Bracket	1
2	69439	(DS) Upper Bag/Frame Mount	1
3	69440	(PS) Upper Bag/Frame Mount	1
4	69443	Perch Mounting Bracket	2
5	69250	(DS) Lower Bag 4.0" Axle Mount	1
6	69251	(PS) 4" Lower Bag Mount	1
7	69330	(PS) 4" Axle/Shock Mount	1
8	69334	(DS) 4" Axle/Shock Mount	1
9	69335	(DS) End-Link Bracket	1
10	69338	(PS) End-Link Bracket	1
11	69319	(PS) Upper Shock Mount	1
12	69316	(DS) Upper Shock Mount	1
13	18498	Trailing Arm Knuckle 10006	4
14	18499	Trailing Arm Knuckle 10005	4
15	1139-182KLD	1139-182KLD Sway Bar	1
16	80140	4139-180KLD	2
17	18769	Shock Bushing	4
18	5748	5748 Firestone Air Bag	2
19	69470	16.5" Panhard Bar	1
20	69444	Brake Reloaction Bracket	1
21	69528	10mm Wingnut	4
22	69446	Perch Mounting Tab	2
23	69452	Shock Reservoir Bracket	2
24	69036	Rear Axle Brake Line Bracket	1
25	16777	19" End Link	2
26	52114.5	14.5" Trailing Arm Bar	4
27	18785	Wide Pan Hard Bar Reducer/Spacer 5/8" To 3/4" Bolt	2
28	18786	Narrow Pan Hard Bar Reducer/Spacer 3/4" To 5/8" Bolt	2
29	80109	(RH) Ball Joint Rod End 3/4-16 x 3/4"	1
30	80110	(LH) Ball Joint Rod End 3/4-16 x 3/4"	1
31	16955	(PHB) Spacer (5/8" Bolt)	2
32	11551	1.5"OD x .53" ID x 1/4"	2

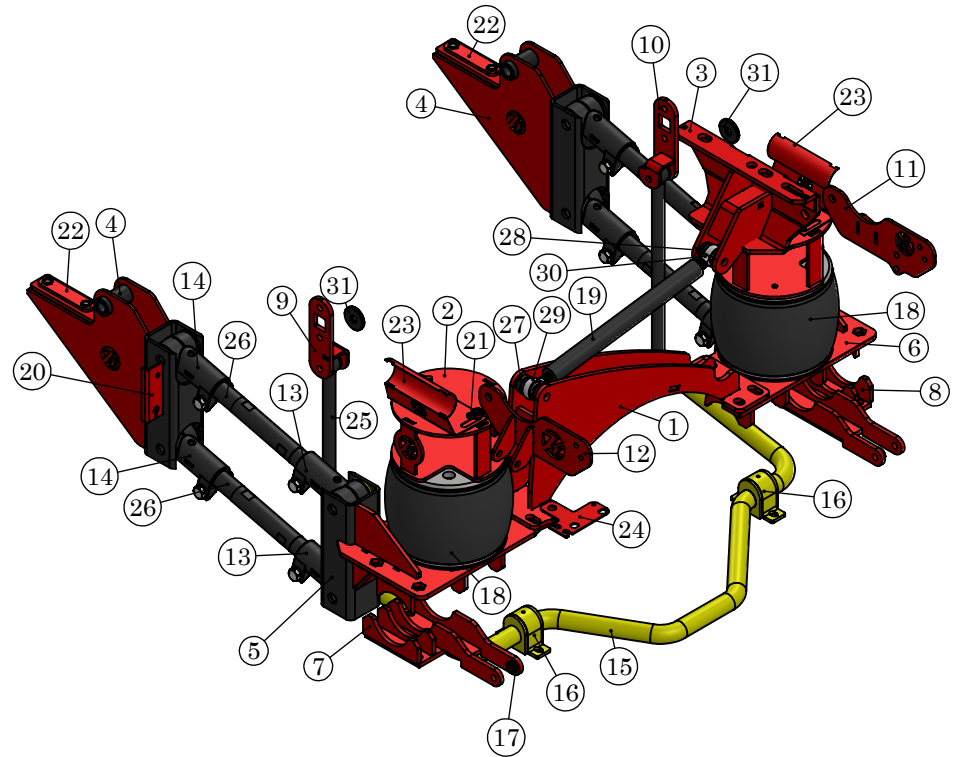

UNLESS OTHERWISE SPECIFIED:
 DIMENSIONS ARE IN INCHES
 TOLERANCES, Unless Specified
 FRACTIONAL 1/32"
 ANGULAR: MACH .5°
 TWO PLACE DECIMAL .03
 THREE PLACE DECIMAL .010

MATERIAL

FINISH

WEIGHT

364.29

DESIGN BY

ZPB

Shelf #/ QTY

NEW DXF

Run QTY

PROPRIETARY AND CONFIDENTIAL

THE INFORMATION CONTAINED IN THIS DRAWING IS THE SOLE PROPERTY OF KELDERMAN MFG. INC. ANY REPRODUCTION IN PART OR AS A WHOLE WITHOUT THE WRITTEN PERMISSION OF KELDERMAN MFG. INC. IS PROHIBITED.

Wednesday, September 6, 2017 10:59:49 AM

Project: 2017 F250-350 Pickup(SRW)

TITLE: 4-link (Rear) - 5-6" Lift - 4.0" Axle

DWG. NO.

KLM-69016

SCALE: 1:24

kelderman

DO NOT SCALE DRAWING

SHEET 1 OF 2

