

Fuel tank may need to be removed temporarily for installation. We recommend beginning install with a low fuel level.



kelderman[®]
AIR SUSPENSION SYSTEMS

Version 1.4
D4RX-45-CC-13
(-2.5" lowering)

KLM18129 /10010498
(stock height)

KLM18133

Stock Height XL

2686 Highway 92—Oskaloosa, IA 52577

Phone: 641-673-5396

www.kelderman.com

2008+ RAM 4500/5500 Chassis Cab 4-Link Rear Installation Instructions



TABLE OF CONTENTS

INTRODUCTION	PAGE 3
PRE-INSTALLATION CHECKLIST	PAGE 4
DETERMINING PINION ANGLE	PAGE 5
EXPLODED DIAGRAMS	PAGE 6-7
DISSASSMBLY	PAGE 8-10
INSTALLATION	PAGE 11-22
ALIGNMENT	PAGE 23
FINAL DIMENSION SHEET	PAGE 24
OWNER GUIDELINES	PAGE 25
KIT IMAGES	PAGE 26-28
TECH SUPPORT/TROUBLESHOOTING	PAGE 29



INTRODUCTION

IMPORTANT!

It is important that the entire installation instructions be read thoroughly before proceeding with suspension installation.

Inspect the entire contents of the shipment prior to beginning with installation.

PRODUCT INSTALLER RESPONSIBILITIES

Installer is responsible for installing the product in accordance with Kelderman Mfg., Inc. specifications and installation instructions.

Installer is responsible for providing proper installation of vehicle components and attachments as well as required or necessary clearance for suspension components, axles, wheels, tires, and other vehicle components to ensure a safe and sound installation and operations.

Installer is responsible for advising the owner of proper use, service, and maintenance required by the product and for supplying maintenance and other instruction as readily available from Kelderman Mfg., Inc.

WARNING!

A correct installation must result in the suspension and axle being “loaded” within the range specified by axle and suspension manufacturers. Please check vehicle specifications and intended usage to insure axle will be within Gross Weight Rating (GAWR). No alteration of any suspension component is permitted.

DEFINITION OF TERMS

WARNING –indicates a potentially hazardous situation which, if not avoided, could result in death or serious injury.

CAUTION –a potential hazardous situation may result in property damage.

NOTE –provide information or suggestions that help you correctly perform a task.

TORQUE –the italicized torque alerts you to tighten fasteners to a specified torque value.

PRE-INSTALLATION CHECKLIST

- Check the vehicle wheel alignment prior to installation to ensure no precondition already exists; record the information for verification.
- Measure and record the wheelbase and centering dimensions before beginning installation.
- Measure and record the height from the ground up to the rear of the frame.
- Measure and record the pinion angle. *See page 5 for specific instructions.*
- Remove the attached body, if applicable. Remember to disconnect all electrical connections and fuel filler tube, before removing the body. The installation can also be completed using a lift to raise the vehicle. If using a lift, chassis body removal may not be necessary but removal of rear wheels will aid in installation.
- If not using a lift, block the front wheels so the vehicle cannot roll.
- Jack up the rear frame of the truck in order to unload the rear leaf springs. Do not lift the wheels off the ground (if not using a lift to install the suspension). Do not jack on the axle itself.

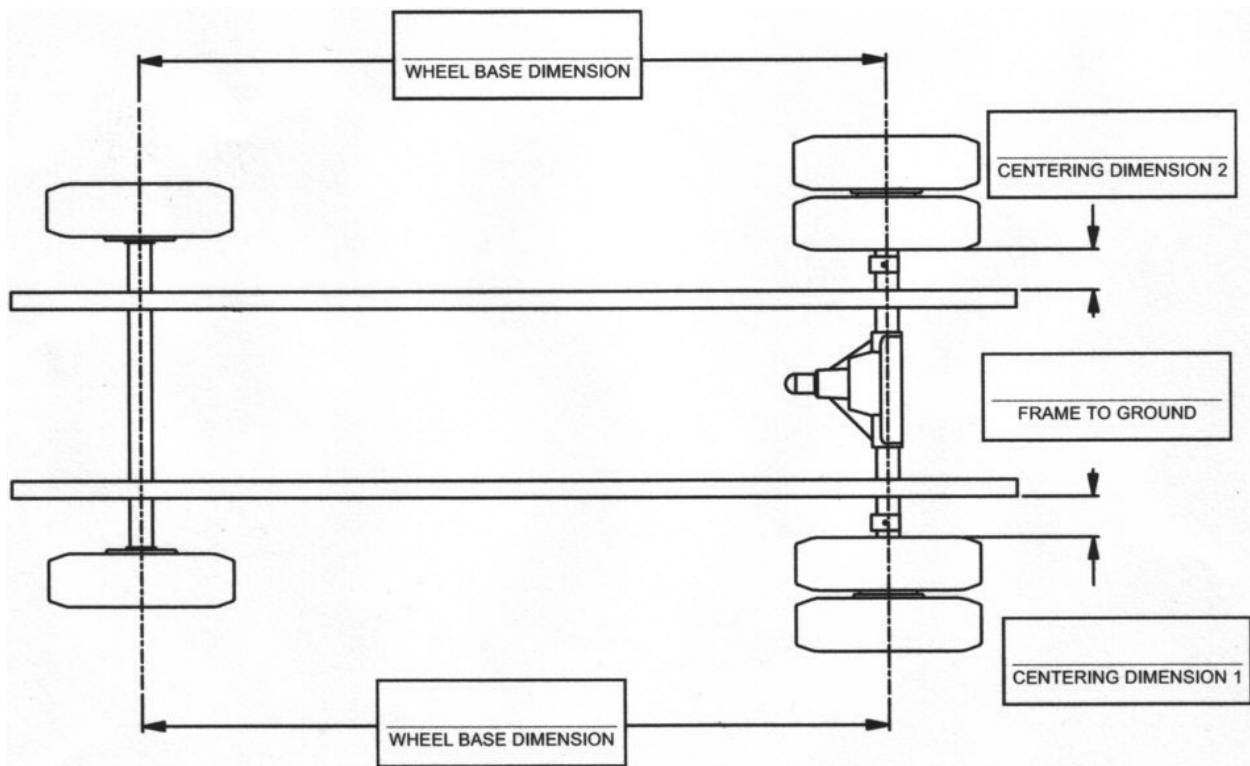

DETERMINING PINION ANGLE

The pinion angle is critical in the correct installation of your Kelderman Air Suspension System. The pinion angle can be easily determined with the use of a magnetic angle gauge.

To measure the angle, find a flat surface to attach angle gauge. Mark the location of your gauge with a marking pen or scribe. Record the angle on the gauge for future reference.

Note: It may be necessary to remove gauge.

Marking the position of the gauge is critical to ensure accurate angle readings during adjustment steps of the assembly of your Kelderman Air Suspension System.



Pinion Angle: _____°



ITEM NO.	PART NUMBER	DESCRIPTION	QTY.
1	13022	3/8" Flat Washer	6
2	13122	3/8"-24 Lock Nut	3
3	52114.5	14.5" Trailing Arm Bar	4
4	80012-5323	Air Bag - Firestone 5323	4
5	30635	Assembly - Bent PHB 18" CTC	1
6	18499	Assembly - Cast Knuckle 10005 - 1" ID	4
7	18498	Assembly - Cast Knuckle 10006	4
8	17947	Assembly - Fuel Tank Crossmember Support	1
9	30676	Assembly - Lower Bag/Axle Mount (DS)	1
10	30675	Assembly - Lower Bag/Axle Mount (PS)	1
11	30678	Assembly - Trailing Arm Side Plate (DS)	1
12	30674	Assembly - Upper Bag Frame Mount (DS)	1
13	30673	Assembly - Upper Bag Frame Mount (PS)	1
14	30679	Assembly - End Link Bracket	2
15	30680	Assembly - Sway Bar D-Ring Adaptor Plate	2
16	30677	Assembly - Trailing Arm Side Plate (PS)	1
17	12110	Bolt - 1/4"-20 x 1" Gr.5	1
18	12217	Bolt - 3/8"-24 X 1.5" Gr.8	3
19	13024	Flat Washer SAE - 1/2" - GR8 - YZ	2
20	12021	Hex Bolt - 1/2"-20 X 3" GR.8	2
21	80058	Hoosier Air Tank w/ Mounts	1
22	13100	Nut - Locking - 1/4" - 20 - GR5	1
23	11551	Plate - 1/4" - 1.5"OD x .53" ID x 1/4"	6
24	16638	Plate - 7ga - Standoff Bracket, Brake Bracket - w/Bends	1
25	80079-1	Sway Bar - 1-3/4" Dia	1
26	80078	Sway Bar Bushing Box - 1-3/4" Dia - 4" Bolt Spacing	2
27	13124	Top Distorted Thread Lock Nut - 1/2"-20 - GR8 - YZ	2
28	30297	Weldment - 9.50" End Link	2
29	18552	Weldment - 17-1/2" End Link - 2-5/8" Offset	2
30	30578	Weldment - Exhaust Hanger	1
31	18130	Weldment - Panhard Bar Crossmember (3/4" Bolt)	1
32	30630	Weldment - Upper Panhard Bar Mount (3/4" Bolt)	1

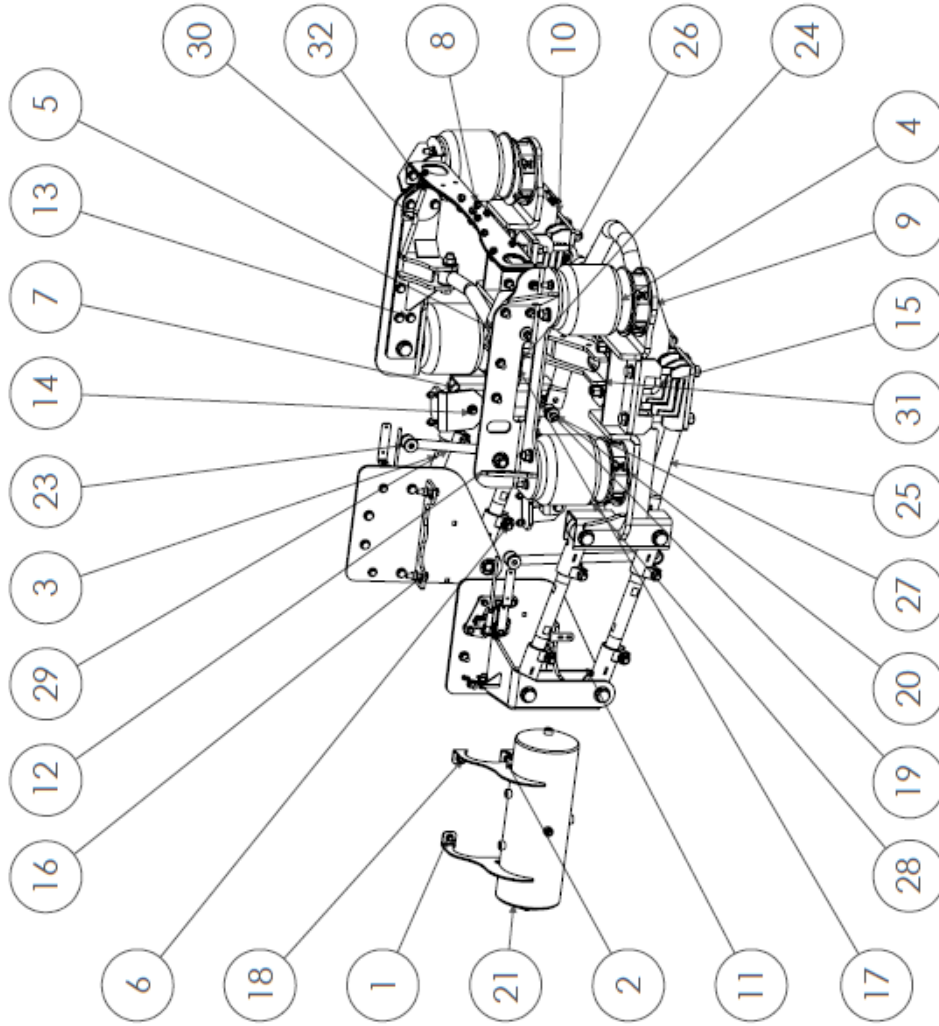

REV	ECN	CHANGE DESCRIPTION	CHANGE BY	DATE

	A	DO NOT SCALE DRAWING	1:50	Approximate Weight = lbs
	MATL. SPECS: DESCRIPTION: 4-Link (Rear) Stock Height			
	UNLESS OTHERWISE SPECIFIED: DIMENSIONS ARE IN INCHES STD. TOLERANCES XX ± .040 XXX ± .000 FRAC. DIM. ± .010 / 2" Dec. ± .3"			
PROJECT: 2013+ Ram 4500-5500 Chassis Cab		PART NUMBER: KLM-1812P		
DESIGN BY:		DATE: 4/27/2022		

SHEET 1 OF 3

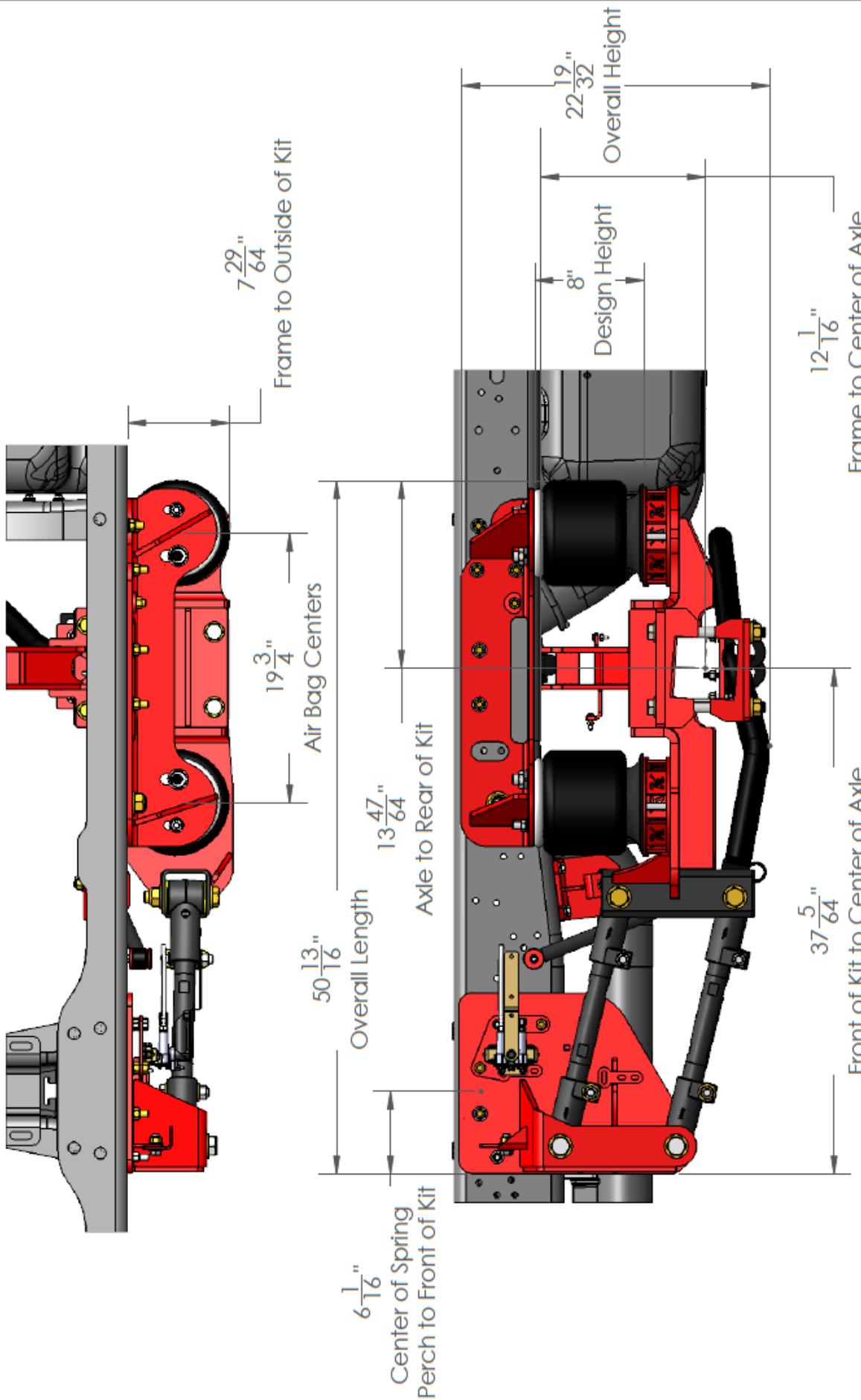

REV	ECN	CHANGE DESCRIPTION	DATE

<p>3D ANGLE PROJECTION UNLESS OTHERWISE SPEC. DIMS. IN INCHES STD. TOLERANCES XX ±.000 XXX ±.010 FRAC. DIM. $\frac{1}{32}$</p>	<p>A DO NOT SCALE DRAWING 1:100 Approximate Weight = 848 lbs</p>
<p>MAIL SPECS: DESCRIPTION: Kfl - 4-Link (Rear) Stock Height PROJECT: 2008+ Ram 4500-5500 Chassis Cab PART NUMBER: KLM-1812P</p>	<p>DATE: 4/27/2022</p>



DISASSEMBLY OF LEAF SPRINGS

- 1) Before disassembling any components, measure the pinion angle and record the angle in the space provided on page 5. This is important as you will need to put the axle back to this measurement at the completion of the installation.
- 2) Jack the rear of the frame so that most of the tension is off of the leaf springs. Place a set of jack stands under the frame, block the tires so that the axle will not move and place a jack stand under the pinion so it does not rotate.
- 3) Remove the leaf springs, spring perches, factory sway bar end link mounts, and the over load pad mounts. You will need to use a torch to cut off the rivets and use a punch to remove the rivets on older models. Newer models use bolts instead of rivets. Use a cut off wheel to remove the over load pad mounts. Make sure that there are no fuel lines, brake lines, or wiring that can be damaged while using a torch.



Place jack under axle to keep from rotating.

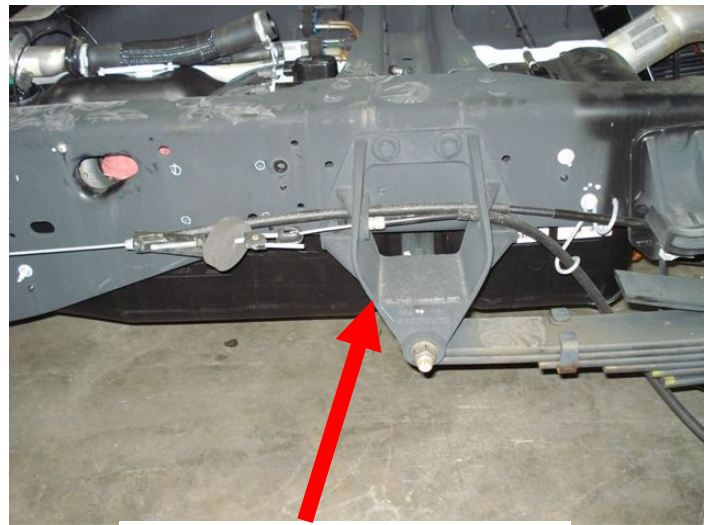

Front leaf spring perch

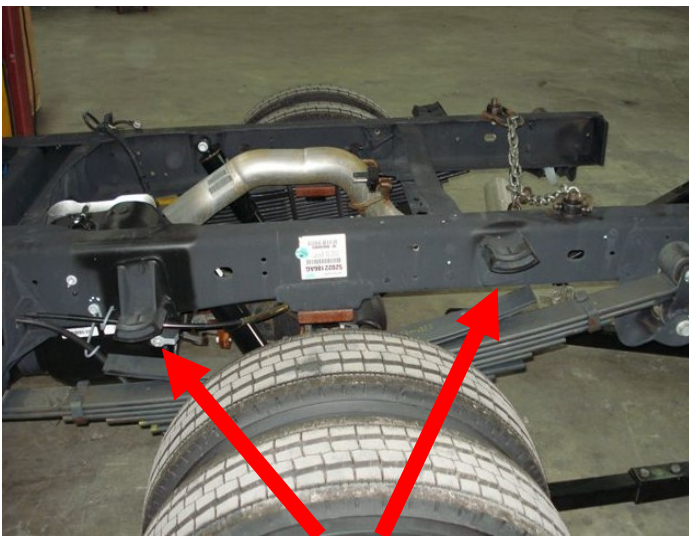

Overload pads

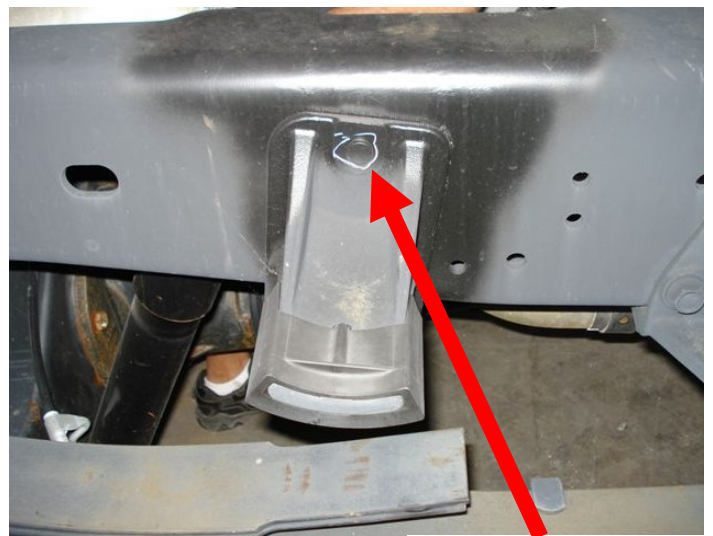

Remove rivet with torch

Cut the bump stop bracket with a cut off wheel

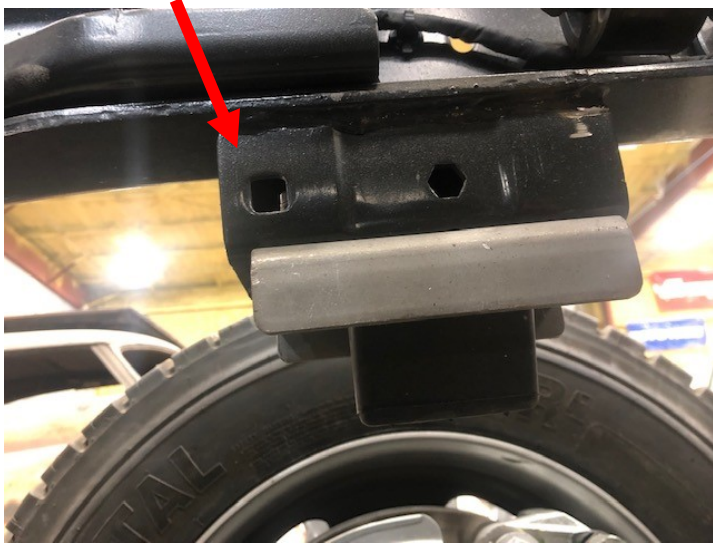

Bumps stop bracket shown removed



DISASSEMBLY OF E BRAKE CABLES AND AXLE PREP

4) On the drivers side, separate the emergency brake cables. The emergency brake cable will be installed onto the front trailing arm mount in a later step.

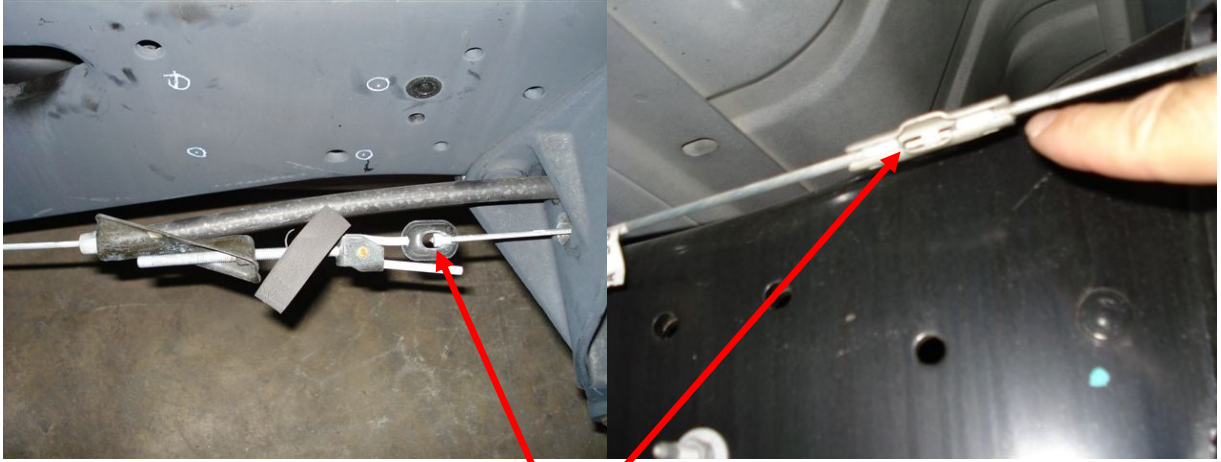

Disconnect brake cables here

5) On the top of the axle, cut off the spring perches that are welded to the axle. Also remove the square block that holds the emergency brake cable in place.



INSTALLATION OF FUEL TANK CROSSMEMBER BRACE

6a) Locate the frame brace kit (pictured below). The assembly fastens to the front side of the fuel tank crossmember. Some of the holes will need to be drilled. Use the plate (Part # 17491) to identify which holes need drilled. Do not install the bolts in the side of the truck frame just yet (bolts #7 in the diagram below). These bolts sandwich the frame with the upper air bag mounts. If installing on a bare chassis, only the front of the fuel tank needs to be lowered. Be extremely careful removing the fuel lines that go to the tank. The 90 degree fitting on the fuel pump is very fragile. Leave all the bolts snug until the upper air bag mounts are installed. Torque the 1/2" bolts to 85 ft./lbs. and the 3/8" bolts to 55 ft./lbs.



ITEM NO.	PART NUMBER	DESCRIPTION	QTY.
<i>Parts</i>			
1	17941	(FICS) Brace	1
2	17942	(FICS) Frame Mount	2
3	17943	(FICS) (DS) Half Brace	1
4	17944	(FICS) (PS) Half Brace	1
5	17948	(FICS) Gusset	2
6	18068	(FICS) Gusset	1
<i>Hardware</i>			
7	12011	Bolt - 1/2"-20 X 2" Gr.8	2
8	12213	Bolt - 3/8"-24 x 1.25" Gr.8	6
9	13022	3/8" Flat Washer	18
10	13024	1/2" Flat Washer	4
11	13122	3/8"-24 Lock Nut	6
12	13124	1/2"-20 Lock Nut	2
13	13874	M10 x 1.50" Thread, 40mm Long	3
14	13919	Lock Nut - M10-1.5mm	3

UNLESS OTHERWISE SPECIFIED:
DIMENSIONS ARE IN INCHES TOLERANCES:
FRACTIONAL ± 1/32"
ANGULAR: MACH: 1 BEND ± 1
TWO PLACE DECIMAL ±.030
THREE PLACE DECIMAL ±.010

MATERIAL

FINISH

WEIGHT
13

Design By: Zach Beltz 2014	Project:
Shelf # / Qty	2013 Dodge 4500/5500 CC
Inventory	Description:
Run Qty:	Fuel Tank Crossmember Support
<small>PROPRIETARY AND CONFIDENTIAL</small>	SIZE DWG. NO.
<small>THE INFORMATION CONTAINED IN THIS DRAWING IS THE SOLE PROPERTY OF KELDERMAN MFG. INC. ANY REPRODUCTION IN PART OR AS A WHOLE WITHOUT THE WRITTEN PERMISSION OF KELDERMAN MFG. INC. IS PROHIBITED.</small>	A 17947
SCALE: 1:8	DO NOT SCALE DRAWING

****If installing on a Dynamax RV chassis see next page for installation instructions of fuel tank crossmember.***

6b) Locate the Dynamax frame brace (kit #10008671) (pictured below). The assembly fastens to the front side of the fuel tank crossmember.

Be extremely careful removing the fuel lines that go to the tank. The 90 degree fitting on the fuel pump is very fragile.

Torque the 3/8" bolts to 55 ft./lbs.

This piece goes in first and needs to be tightened up before center section is installed

To install the center section plate, you must disconnect the fuel lines. The fuel lines travel through the hole in the middle of the center section plate along with the exhaust bracket.

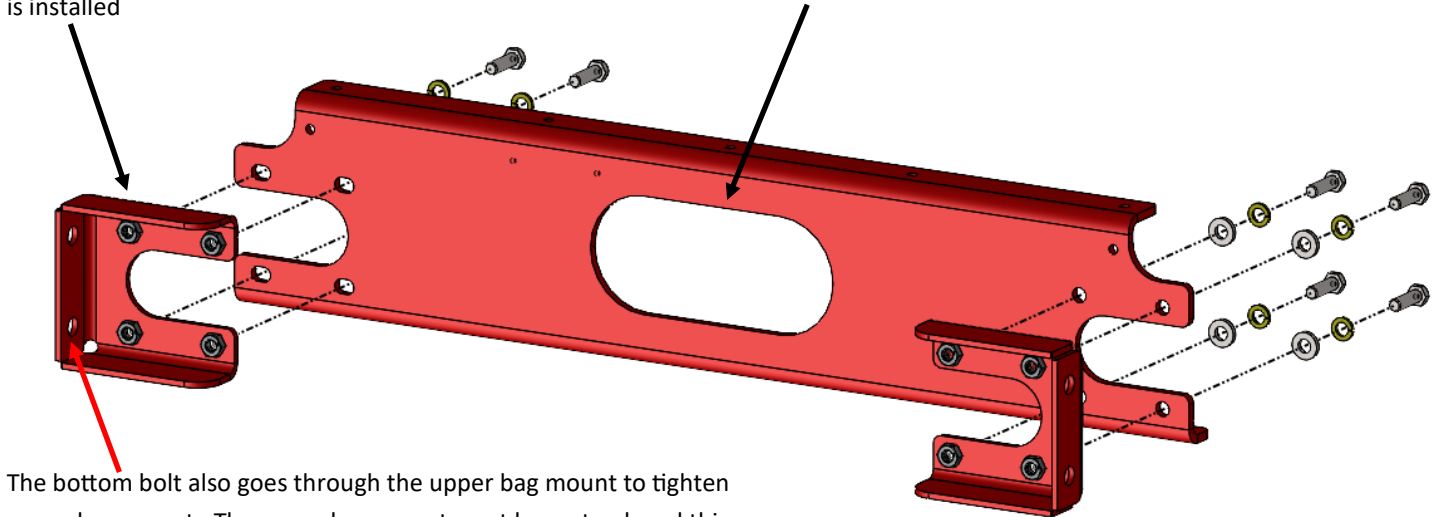

The bottom bolt also goes through the upper bag mount to tighten upper bag mount. The upper bag mount must be on track and this piece must be tight before installing center section.

ITEM NO.	PART NUMBER	DESCRIPTION	QTY.
1	10008670	Plate - 1/4" - Fuel Tank Crossmember - Frame Brace - w/Bends	1
2	10008668	Weldment - Fuel Tank Crossmember - Frame Bracket	2
3	13022	3/8" Flat Washer	8
4	13046	3/8" Lock Washer	8
5	12212	Hex Bolt - 3/8"-16 x 1-1/4" - GR5 - Z	8

REV	ECN	CHANGE DESCRIPTION	CHG#	DATE

3/8" UNLESS OTHERWISE SPEC. DIMS. IN INCHES
 STD. TOLERANCES: X.3 ±.010, X.5 ±.015, X.125 ±.010, FRACTIONS ±.010
 DRG. 2 OF 2

A (DO NOT SCALE DRAWING) Approximate Weight = lbs
 MATERIAL SPEC:
 DESCRIPTION: Assembly - Dynamax RV - Fuel Tank Crossmember
 PROJECT: 2019 KAM 680 Chassis Cab - Dynamax Iso 5 Series Class C Motorhome RV
 PART NUMBER: 10008671
 DESIGN BY: Trey Anderson DATE: 8/5/2022

SHEET 1 OF 1

INSTALLATION OF UPPER PANHARD BAR MOUNT AND EXHAUST HANGER

7) Locate the passenger side upper bag mounts (part # 17038) and the pan hard bar mounting plate (part # 17034) and exhaust hanger. Use two 1/2 x 2" bolts to "sandwich" the frame between the upper bag mount, pan hard bar mounting plate, and the supplied exhaust hanger. Use four 1/2 x 2" bolts and one 7/8 x 3" bolt to finish installing the assembly. You will need to drill a 1/2" hole for the center most 1/2" bolt. **Torque the 1/2" bolts to 85 lb./ft. and the 7/8" bolt to 275 lb./ft.**

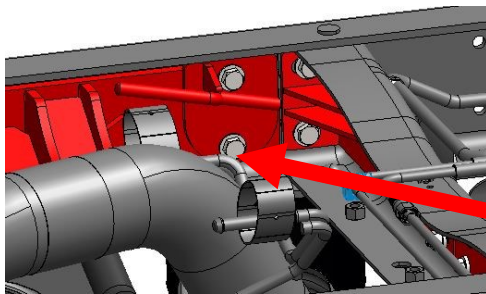

Exhaust hanger mounts on the inside of the frame with these two 1/2" bolts

UPPER PHB MOUNT

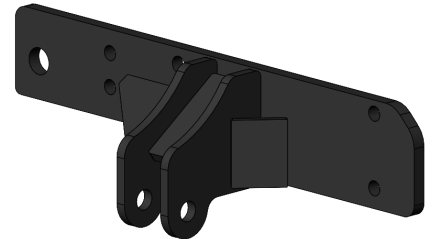

Passenger Side

This rivet gets drilled out to 1/2" for another bolt (supplied with frame brace)

1/2 x 2" bolts share with frame brace

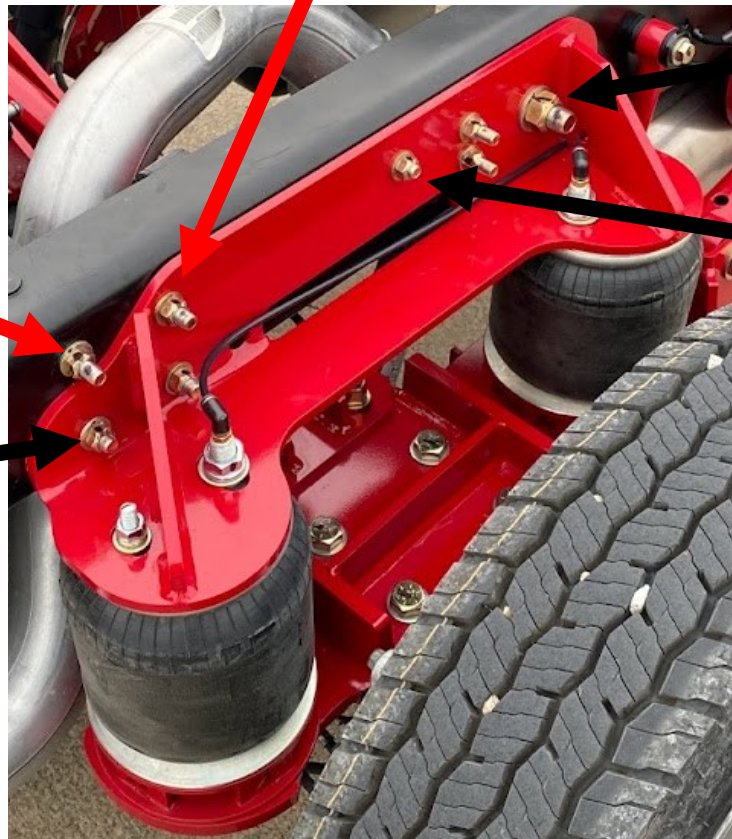

7/8 x 3" bolt

Drill this hole

8) Locate the drivers side upper bag mount (part # 17039). It fastens to the frame with the 1/2" x 2" bolts and the one 3/4 x 2"



INSTALLATION OF THE LOWER AIR BAG MOUNTS

10) Locate the lower bag mounts (driver side part # 17030, passenger side part # 17031), and the eight 3/4 x 8 1/2" bolts. Insert the 3/4" bolts through the lower bag mounts. Place these mounts over the axle and measure 3 3/4" from the inner brake caliper mount surface to the lower bag plate (please see Fig.1). Fasten to the axle using the lower axle clamps, 3/4" flat washer, and 3/4" lock nuts. If you are installing the stock height kit, locate the four 2" air bag spacers (part# 69088) and fast to the air bags with the 1/2x2" bolts. Torque these bolts to 85 ft./lbs. **NOTE:** Check the orientation of the lower axle clamps. Make sure that the tall angle of the bottom axle towards the front of the truck. Drop the bolts down from the top. Do not tighten the bolts until the panhard bar mounts and panhard bar have been installed.

Drivers side lower bag mount with 2" spacers (stock height)

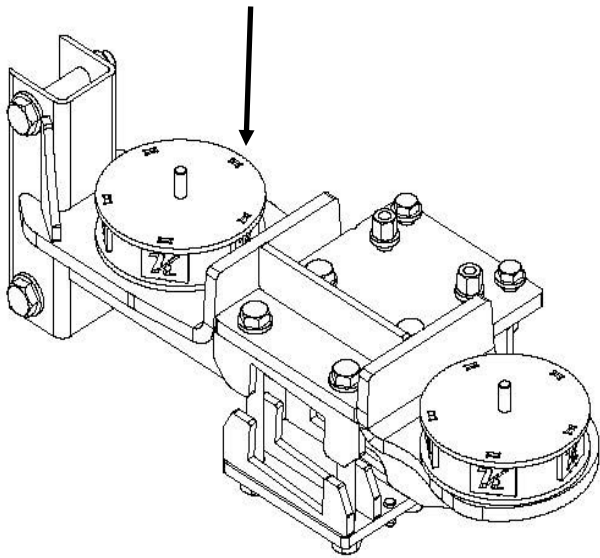

Passenger side lower bag mount (lowering kit)

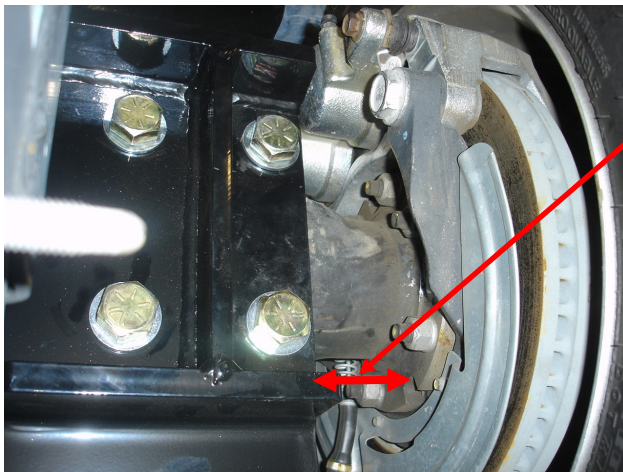
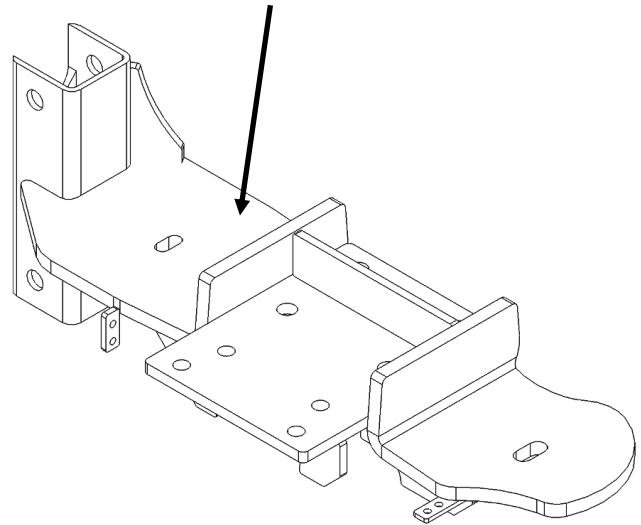

3 3/4"
SIDE-PLATE

Front of lower axle clamp

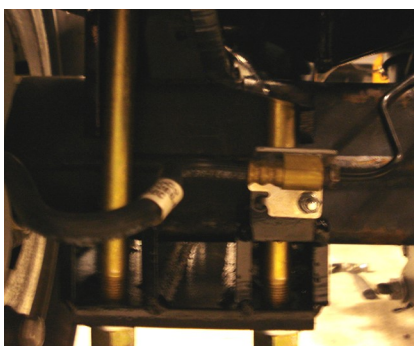
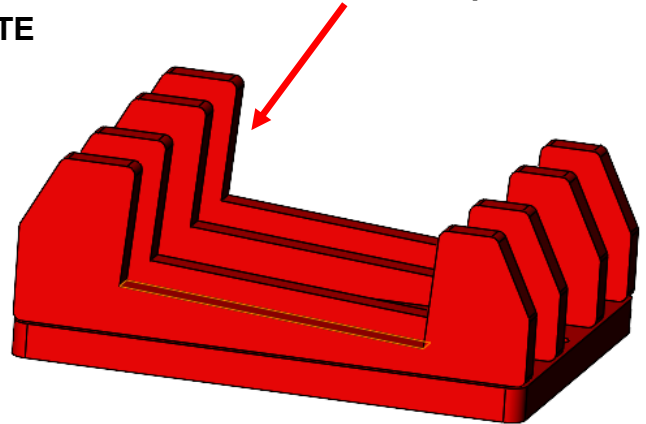

11) Relocate brake line mount to the lower axle clamps and secure with a 1/4" x1" bolt, flat washers, and nut. **Torque bolts to 60 lb./in.**

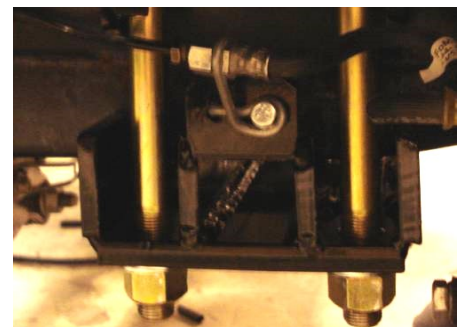

12) For the 2014 and newer model year Ram 4500/5500 Chassis Cab trucks there is an additional exhaust hanger from the factory. The upper stud hanger (shown below) needs to be cut off at the first bend of the exhaust. The other exhaust hanger must also have the lower stud cut off one inch from the head of the stud. (shown below)



13.) For the installation of the side plate on the passenger side, a bolt is removed from the factory exhaust hanger. A pre-drilled hole in the side plate will allow for a bolt to be placed through the factory hanger and frame and into the side plate. Remove the factory bolt and make clearance through the side plate using a 1/2" drill bit. Use the 7/16" x 2" bolt provided as shown below.

Below , left—Remove factory exhaust hanger shown.

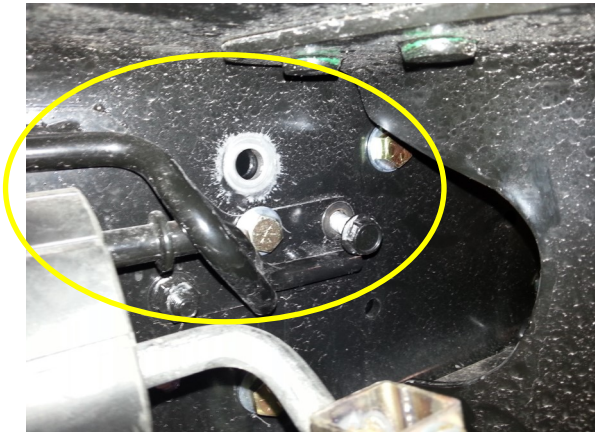

Below, right— Hole drilled to allow clearance for side plate bolt into exhaust hanger.

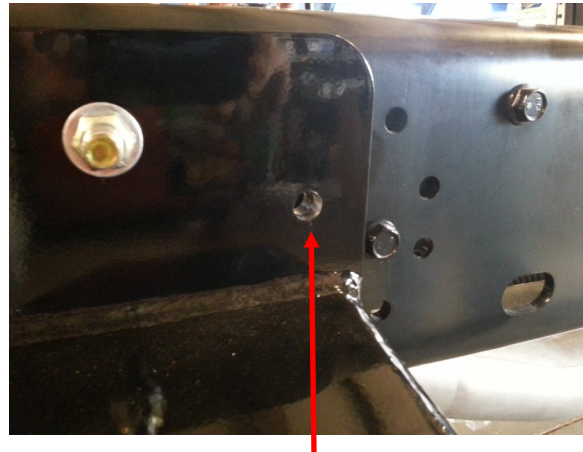

Drill through this hole

Below, — Section of exhaust hanger shown removed.



INSTALLATION OF LOWER PANHARD BAR MOUNT

15) Locate the driver side upper air bag mount (part #17039). You will use five 1/2 x 2" bolts and one 7/8 x 2" bolt to secure the upper bag plate to the frame. **Torque the 1/2" bolts to 85 lb./ft. and the 7/8" bolt to 275 lb./ft.**

16) Locate the cross member (part #17035). The stock height cross member is 2" taller than the lowering kit cross member. Fasten to the lower bag mounts using the four 5/8x2" bolts and the U-bolts. The pan hard bar mounting point should be installed on the drivers side. Slide the U-bolts up from the bottom and start the nuts but do not tighten. Once you have all the bolts started you can tighten bolts using a crisscross pattern beginning with the bottom air bag mounts and the U-bolts last. **Torque 3/4" bottom air bag bolts to 175 lb./ft., the U-bolts to 85 lb./ft., and the 5/8" bolts to 150 lb./ft.**

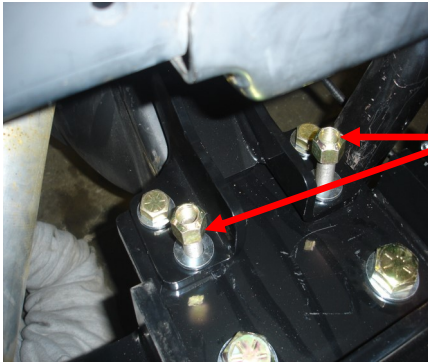

U-Bolt

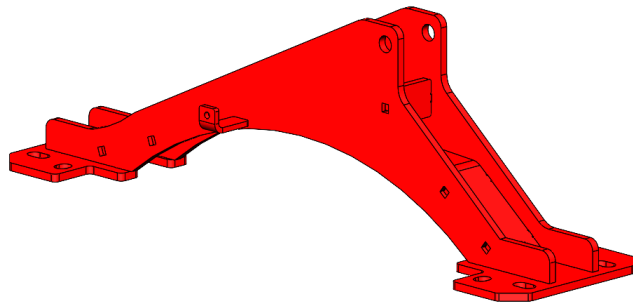

CROSSMEMBER

17) Locate the pan hard bar (part # 17032). Use the 5/8 x 4 1/2" bolt, flat washers, lock nuts, and 1/8" spacers to fasten the pan hard bar in on the driver side. Use the 3/4 x 4" bolt, flat washers, and lock nuts to fasten the pan hard bar the upper mount on the passenger side. **Torque the 3/4" bolts to 150 lb./ft.**



PAN HARD BAR (PHB)

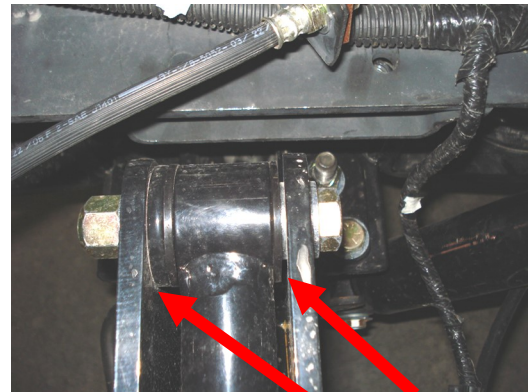

1/8" spacers

18) Locate the four air bags (part # F5323). Use the 3/4" and 1/2" nuts, flat and lock washers to fasten the top of the air bags into place. Use the 1/2x3 1/2" bolts to fasten the bottom of the air bags into place. **Torque these to 35 lb./ft.**



INSTALLATION FOR 84" CAB TO AXLE SWAY BAR

19A) This is the installation process for 84" cab and chassis sway bar end links. If you have a 60" Cab to Axle Chassis, go to the next page. Locate the sway bar end link relocation bracket. 2008-2013 MY fasten to the frame using the four 7/16 x 2" bolts, **torque to 50 lb./ft.** (MY 2014 and newer use M10 x 40 bolts). Locate the sway bar, end links, "D" bushings, and adapter plates. Fasten the sway bar and the "D" bushings to the adapter plate. Fasten the end links to the sway bar and sway bar relocation bracket using 1/2" x 3" bolts, flat washers, and lock nuts.

84" Sway bar installation completed

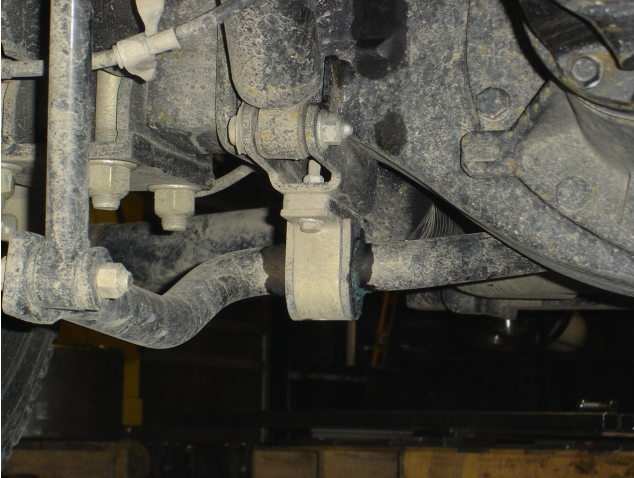

Passenger side relocation bracket

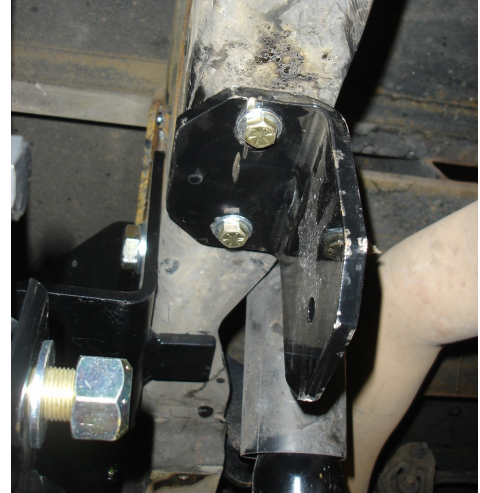

Passenger side



Driver side



2017+ Sway bar mounting pad has 4 holes in the bottom, so no need for relocation plate. Drill out 1st and 3rd holes from the front of the truck and mount D-ring.

60" CAB TO AXLE SWAY BAR INSTALLATION

19B) The 60" CA chassis does not use end link relocation brackets. The end link bolts right to the side of the frame. The end links are also angled so take note. Use the diagram below to see where the end link will attach to the frame. A 1/2" hole will need to be drilled out on each side. On the passenger side, make sure the end link does not hit the particulate filter. If it rubs, use a washer between the sway bar and endlink and/or frame. On the drivers side make sure not to drill into any fuel lines when drilling the hole. Make sure to use the large flat washer on the outside of the end link.

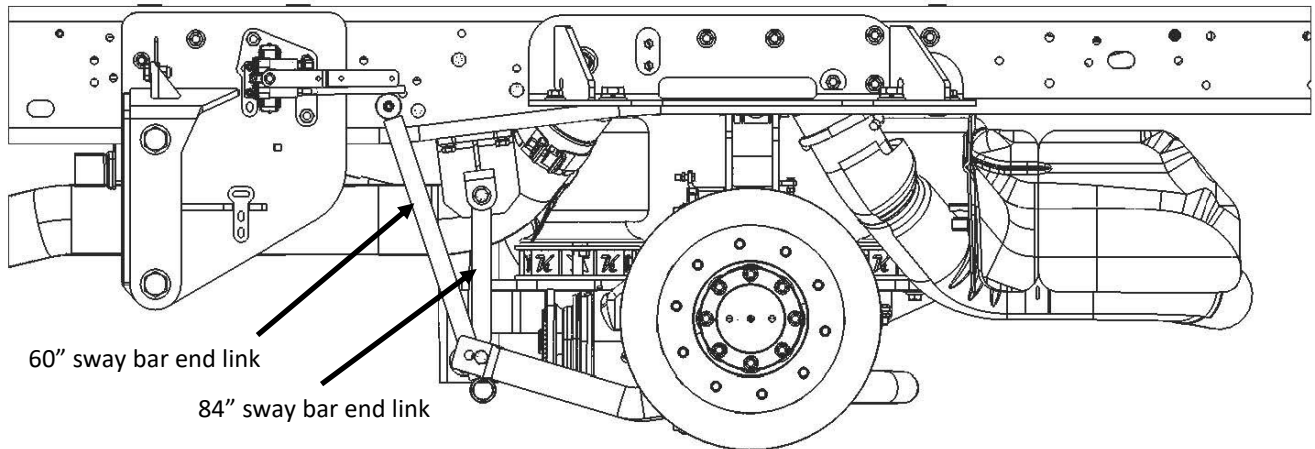

INSTALLATION OF TRAILING ARMS

20) Locate the trailing arms and set them so there is 9" between the knuckles. This is a good starting point. Set the upper trailing arm fastens into the front side plate using 7/8 x 5" bolts, flat washers, and lock nuts, inserting the bolts from the outside in. **NOTE: On the driver side, make sure to run the emergency brake line between the trailing arms.** The rear of the upper trailing arm fastens into the lower bag mount using 7/8 x 5" bolts, flat washers, and lock nuts inserting the bolts from the inside out. Do not tighten the bolts until alignment is completed.

21) The lower trailing arms fasten into the front side using 7/8 x 7 1/2" bolts, flat washers, and lock nuts inserting the bolts from the outside in. The rear of the lower trailing arms fastens into the lower bag mount using 7/8 x 5" bolts, flat washers, and lock nuts from the inside out. Do not tighten bolts until alignment is completed.

Note: On Dynamax RV, you have to put the right hand knuckles in the DS side plate before putting it on the frame and left hand knuckles in the PS side plate. Pinch bolts will be orientated from inside out.

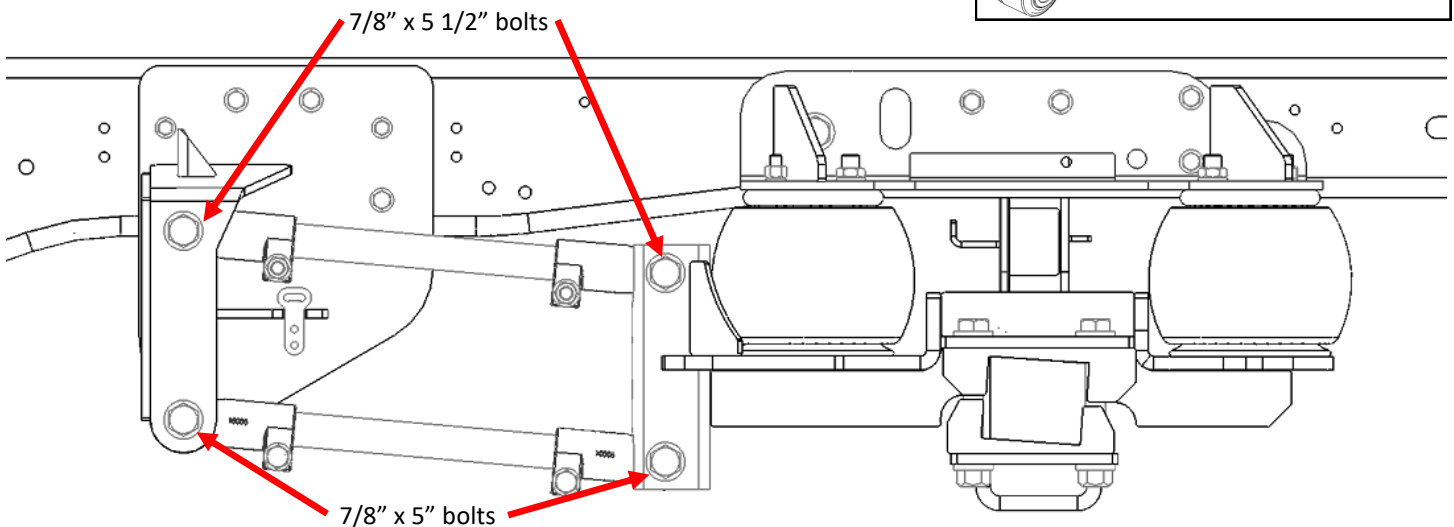
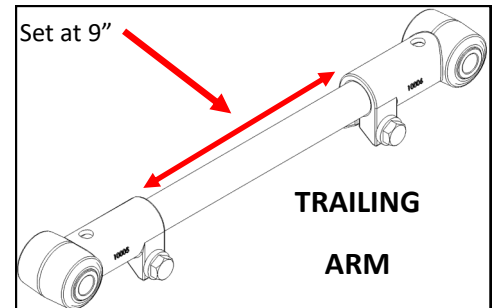

Drill and tap location shown with 1/4"-20" tap and bolt in loop clamp with 1/4"-20 x 1/2" Allen head socket bolts.

Attach E brake cable to loop clamp.

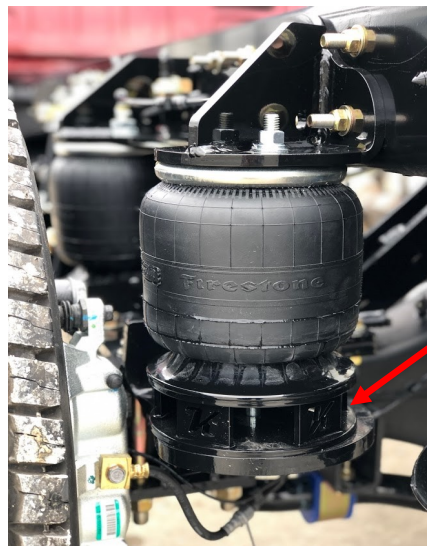

22) Check to make sure the tailpipe has clearance and isn't rubbing on the fuel tank plastic skid plate. Make sure you can put your hand in between. If not, adjust the upper exhaust hangers by bending them accordingly. **NOTE:** On lowering kit models, when dumped, the exhaust may hit on the Panhard bar. This is normal and will not effect anything.



ALIGNMENT

- 1) Once all the brackets are installed and tightened, adjust the jack stands that are holding up the rear of the frame so that the distance between the upper and lower air bag mounting brackets is 8". Once this height is set, refer to the original measurements taken in pre-installation checklist. **After the adjustments are made torque all the 7/8" bolts to 275 lb./ft.**
- 2) Check wheelbase measurement on vehicle: To adjust wheelbase, turn either both left or both right trailing arms as a set. This will prevent the trailing arms from binding. Keep checking measurement and adjusting until your wheelbase measurement is the same on both sides within 1/8".
- 3) Check pinion angle with angle gauge. It is important to place gauge in exact position used to take measurement in the beginning. To adjust pinion angle, adjust either both top or both bottom trailing arms. Always turn them the same direction and only 1/2 turn at a time. Keep checking measurements and adjusting until your pinion angle is the same as your initial measurement.

Torque Table

	Fastner	Nut/Bolt	LB/FT	Torqued?	Paint mark?
Front trailing arm mounts	1/2"	UNF Nuts	85		
Front trailing arm mounts	5/8"	UNF Nuts	150		
Front trailing arm mounts	7/16"	UNF Nuts	50		
Lower bag mounts	3/4"	UNF Nuts	175		
Upper bag mounts	1/2"	UNF Nuts	85		
Upper bag mounts	5/8"	UNF Nuts	150		
Air bags	1/2"	UNC Nuts	35		
Air bags	1/2"	UNC Bolts	35		
Air bags	3/4"	UNF Nuts	35		
Pan hard bar	5/8"	UNF Nuts	75		
Pan hard bar U-Bolt	1/2"	UNF Nuts	85		
Pan hard bar mount	1/2"	UNF Nuts	85		
Pan hard bar mount (lower)	5/8"	UNF Nuts	150		
Trailing arms (pinch bolts)	5/8"	UNC Nuts	150		
Trailing arms	7/8"	UNF Nuts	275		
D bushing (factory OEM)	12 mm	Bolts	75		

FINAL DIMENSION SHEET

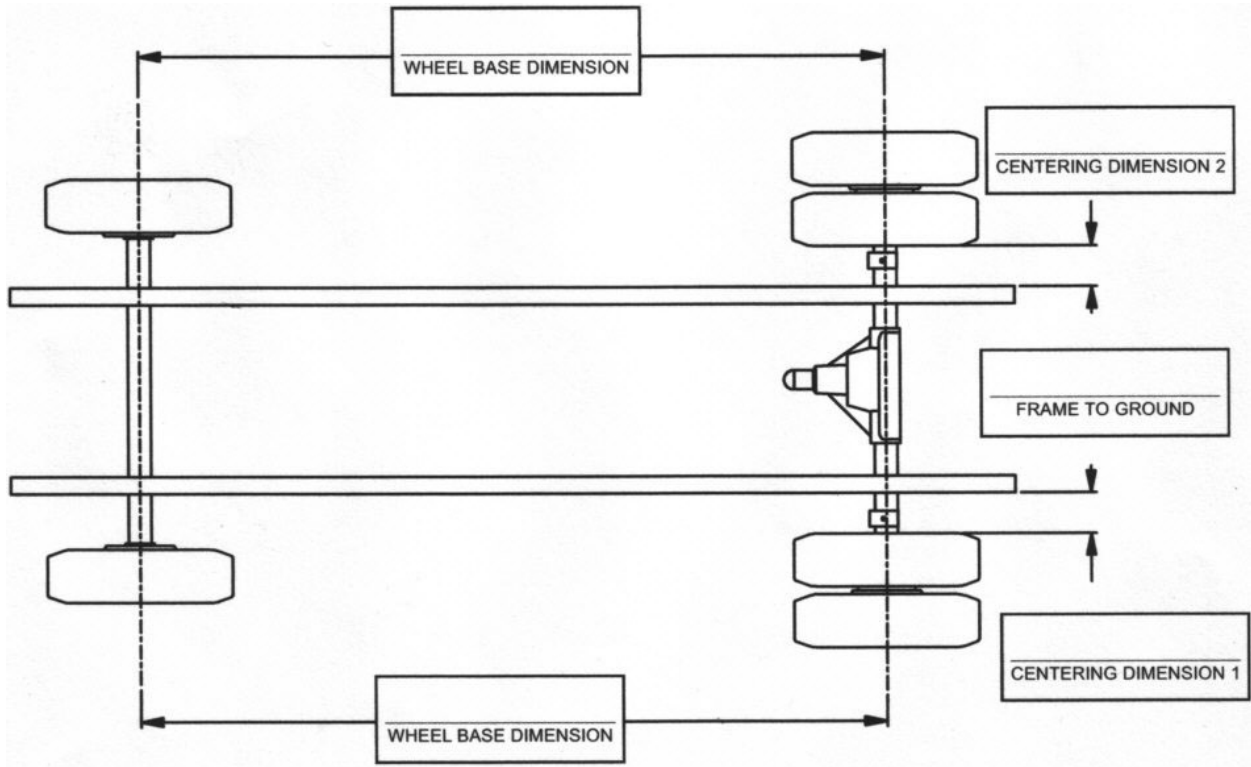

NOTES:

OWNER GUIDELINES

The Kelderman suspension needs no lubrication and little maintenance. However immediate corrective action should be taken if a serious malfunction occurs.

CAUTION! If maintenance or service is to be done on the air system be sure to drain all air from the system. Serious injury could occur if components are removed while the system is full of air.

PRODUCT OWNER RESPONSIBILITIES

- Owner is solely responsible for pre-operation inspection, periodic inspections, maintenance, and use of the product as specified in the particular Kelderman Mfg. instructions available by product model, except as specified in this warranty, and for maintenance of other vehicle components. Of particular importance is the re-torque of fasteners including axle bolts, four link bolts, and pan hard bar bolts. This re-torque must be performed within 90 days of the suspension being put into service.
- Owner is responsible for “down time” expenses, cargo damage, and all business costs and losses resulting from a warrantable failure.
- The Kelderman Air Suspension is fully automatic in controlling the height of the chassis. No manual intervention to control air pressure is needed during the course of operation.
- On a mechanical control system the compressor switch must be on for the compressor to operate. During the starting circumstances, (i.e. extremely cold weather) it is recommended to turn the compressor switch off until the vehicle is running so it will not draw current from the battery. The compressor is controlled by the pressure switch located in the air control box. This switch automatically turns the compressor on when the tank pressure falls below the preset low point of the pressure switch and turns the compressor off when the tank pressure reaches the preset high point of the pressure switch.
- On a mechanical control system the low pressure warning light indicates a severe drop in the tank pressure (below 45 PSI). Immediate corrective action should be taken to determine the cause of air loss. Compressor switch should be turned off if low pressure warning light is on and remains on even after the compressor has run for a normal period of time. **NOTE: The low pressure warning light could come on briefly when the “dump” feature is being used.**
- It is important to release any moisture contained within the air tank on a regular basis. This is done by pulling on the attached release cable for approximately 5 seconds. Not releasing the moisture on a regular basis could cause the system to operate properly.
- On an electronic control system it is vital that you remove the main fuse located by the battery during any jump starting of the battery or replacement of parts.

CHECK AT EVERY VEHICLE SERVICE INTERVAL:

Check ride height to ensure that it is within 1/4”.

Check for air leaks around fittings.

CHECK AFTER THE FIRST 1000 MILES:

Recheck and tighten any loose fasteners.

Check for any loose or worn components.

CHECK AFTER EVERY 30,000 MILES:

Check trailing arm and pan hard bar bushings for wear; replace if worn.



Rear fuel tank delete truck shown







If you require technical support during installation or use of a Kelderman Air Suspension System, please call our toll-free number, 1.800.334.6150, and one of our technicians will be happy to assist you. Kelderman Air Suspension Systems is open 7-4:30 PM Central Standard Time. If your vehicle operates with a Hadley electronic air control system, please call 616-608-1224 for support with the air control system.

Troubleshooting Tips

- Decreased ride quality — Measure the height of the air bags at the bag closes to the cab on each side. The bags should measure 8" tall between the plates for proper ride quality.
- Noise from the suspension — Noise over bumps could indicate worn bushings from wear and tear on the suspension. Inspect pan hard bar, trailing arm, sway bar end links and sway bar bushings for damage. Replace as necessary.
- Increased body roll — Inspect rear sway bar, end links, bushings w/ D-Rings for damage. Replace as necessary.
- Loss of air pressure — Follow air lines on the vehicle and inspect for damage. Check all fittings and connectors and air bags for damage. A damaged component should be replaced as quickly as possible to avoid downtime.
- Compressor Operation — If the compressor does not turn on to fill the tank/system, check the fuse for the system commonly located by the battery under the hood. If the compressor will not turn off check to see if there is air pressure in the tank. If the tank has pressure, locate the pressure switch and check for voltage.

For further assistance please call our toll-free number, 1.800.334.6150, to receive support.