

UNLESS OTHERWISE SPECIFIED: DIMENSIONS ARE IN INCHES TOLERANCES: FRACTIONAL $\pm 1/32"$ ANGULAR: MACH ± 1 BEND ± 1 TWO PLACE DECIMAL $\pm .030$ THREE PLACE DECIMAL $\pm .010$	Design By:	Zach Beltz 2014	Project: 2008+ F450/550 CC (Rear)	
	Shelf # / Qty			
	Inventory		Description: Kit - Frame Fix	
	Run Qty:			
MATERIAL SEE ABOVE	PROPRIETARY AND CONFIDENTIAL THE INFORMATION CONTAINED IN THIS DRAWING IS THE SOLE PROPERTY OF KELDERMAN MFG. INC. ANY REPRODUCTION IN PART OR AS A WHOLE WITHOUT THE WRITTEN PERMISSION OF KELDERMAN MFG. INC. IS PROHIBITED.		SIZE	DWG. NO.
FINISH			A	KLM-17555-(FF)
WEIGHT 572.32			SCALE: 1:100	DO NOT SCALE DRAWING

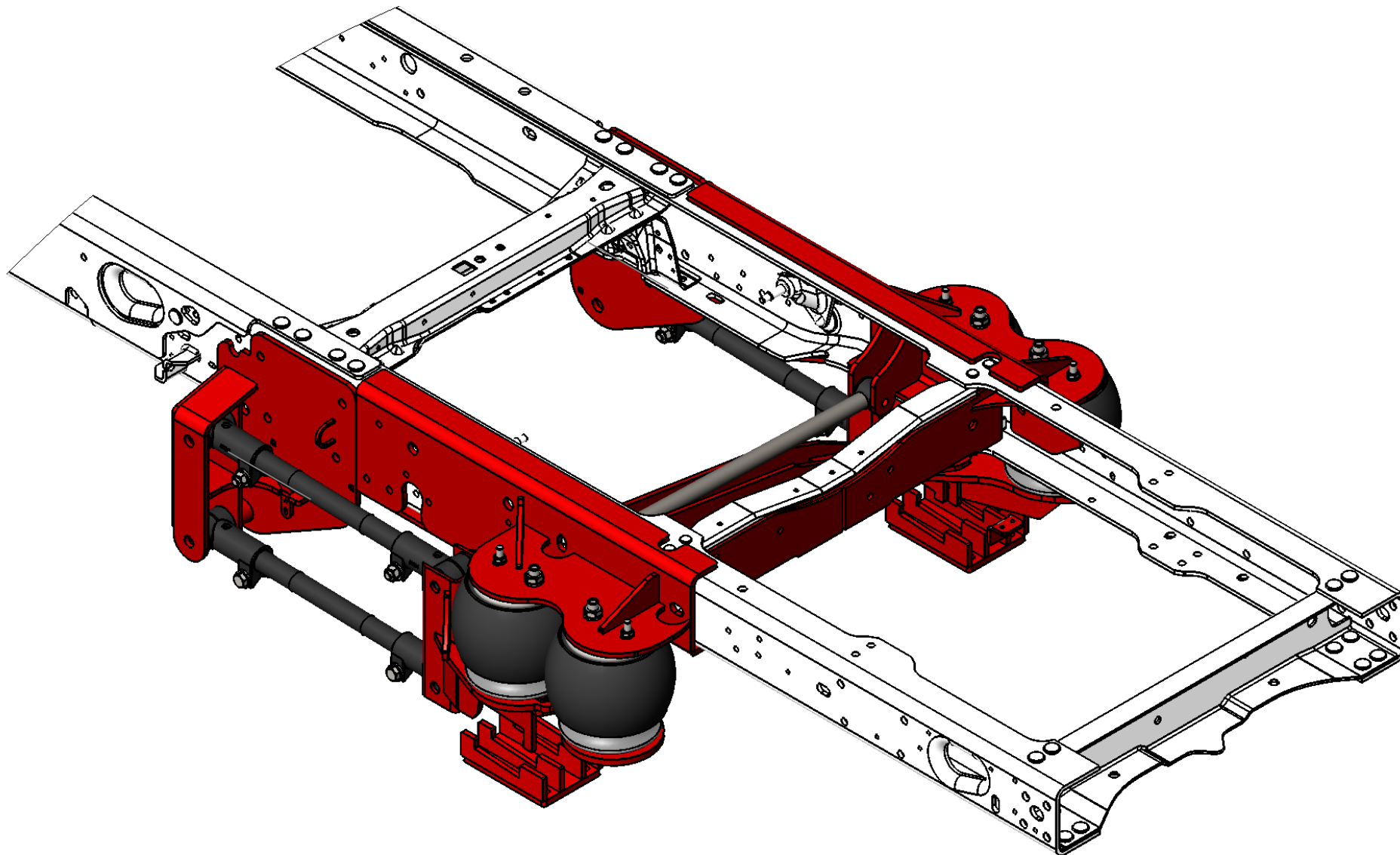

UNLESS OTHERWISE SPECIFIED: DIMENSIONS ARE IN INCHES TOLERANCES: FRACTIONAL $\pm 1/32"$ ANGULAR: MACH ± 1 BEND ± 1 TWO PLACE DECIMAL $\pm .030$ THREE PLACE DECIMAL $\pm .010$	Design By:	Zach Beltz 2014	Project:	
	Shelf # / Qty		2008+ F450/550 CC (Rear)	
	Inventory		Description:	
	Run Qty:		Kit - Frame Fix	
MATERIAL SEE ABOVE	PROPRIETARY AND CONFIDENTIAL THE INFORMATION CONTAINED IN THIS DRAWING IS THE SOLE PROPERTY OF KELDERMAN MFG. INC. ANY REPRODUCTION IN PART OR AS A WHOLE WITHOUT THE WRITTEN PERMISSION OF KELDERMAN MFG. INC. IS PROHIBITED.		SIZE	DWG. NO.
FINISH			A	KLM-17555-(FF)
WEIGHT 572.32			SCALE: 1:100	DO NOT SCALE DRAWING