



2686 Highway 92 - Oskaloosa, IA 52577
phone: 641.673.0468 - fax: 641.673.4168
www.kelderman.com

2013+ Ram 3500 Pickup 4-Link Rear & 3" Lift Kit Installation Instructions



Installation

1. Measure the pinion angle and write the angle down. This is important because you will need to put the axle back to this measurement after the installation. Also, take a measurement from the front of the axle to a location on each side of the frame. Write these measurements here. Pinion angle _____. Right side _____
Left side _____ **NOTE: All the bolts in this kit use a flat washer on each side of the bolt.** It is not required to remove the bed, but if you have the ability to do so, it will make the install much easier.
2. Jack up the rear of the frame so that most of the tension is off the leaf springs. Place a set of jack stands under the frame. Block the tires so the axle won't move and place a jack stand under the pinion so it doesn't rotate. Remove the leaf springs. Remove the rubber bumpers fastened to the bottom side of the frame.
3. **On stock height units only:** The "U" shaped bump stop mount needs to be cut off each side of the frame. If the bump stop mount is not removed, the truck will end up with a 2-3" lift. If removing the bump stop mount, use a torch, cut off wheel, plasma, etc. to remove the bump stop mount. Once it's removed, grind it smooth and remove the paint as the upper bag mount will be welded to it.



For stock height trucks:

Cut the factory bump stop off here. It is required to cut on the inside and outside of frame.

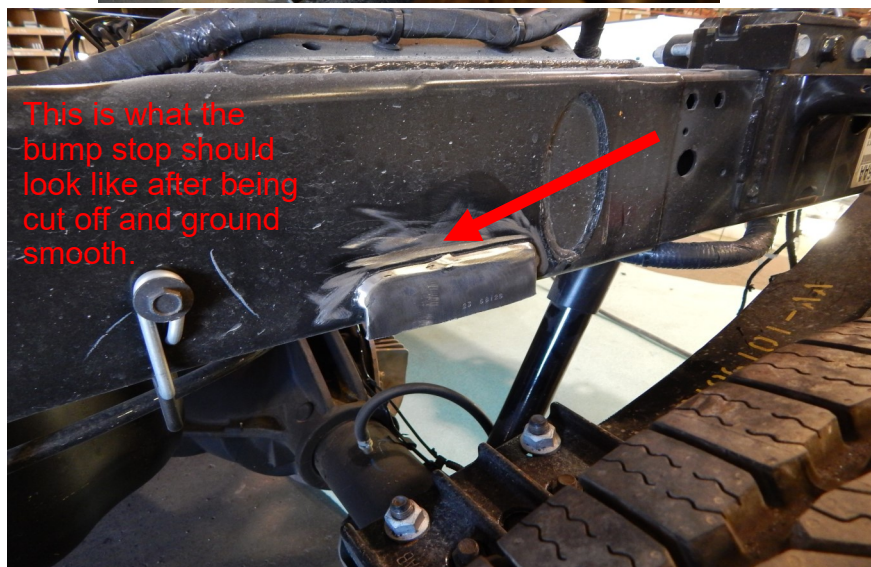

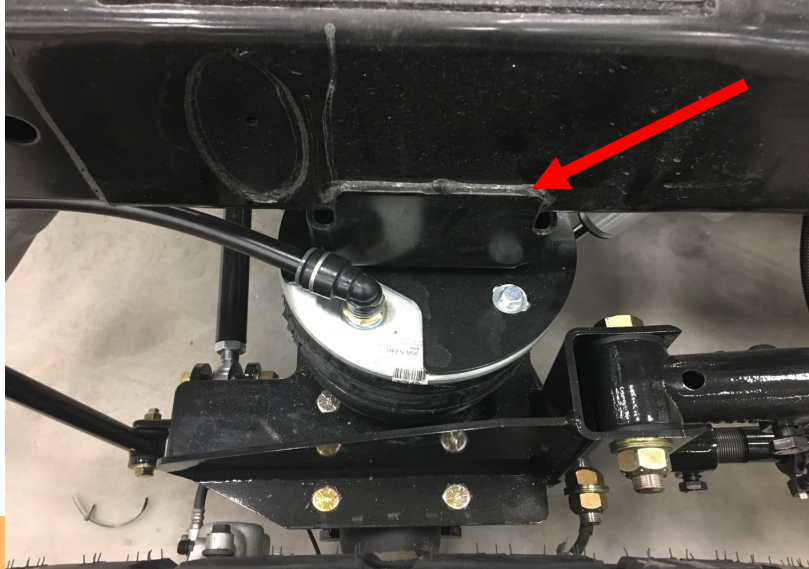

Bump stop mount shown installed with the upper airbag mount for a 3" lift kit application (KLM51821)

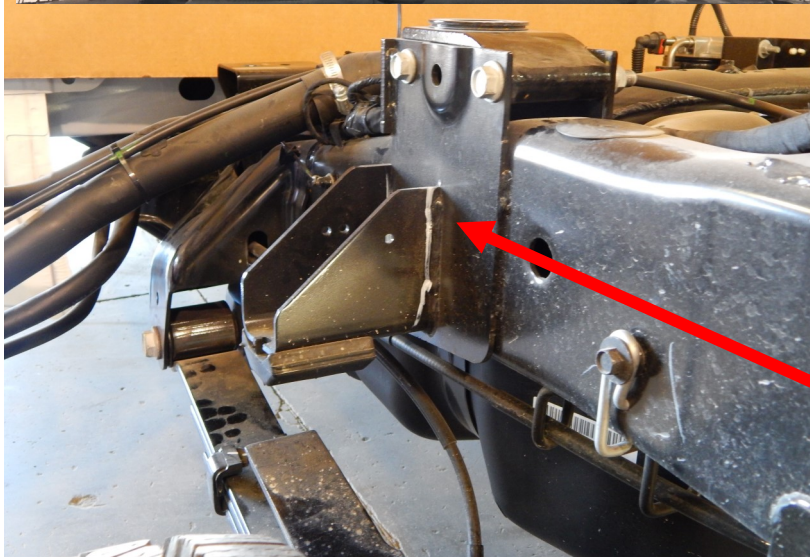

3. The front over load pads will need to be cut off and removed on both sides of the frame. Use the same method used in removing the bump stop in step two. Once removed grind the area smooth. You will have to weld on this area in step 6.

Remove front over-load pads with grinder. When removed, Part # 18211 will be welded into position.





4. Locate the driver's side frame mounting plate (Part # 18211). Mount it to the side of the frame with the two 7/16 x 5 1/2" bolts. Do not torque them yet. Just snug them up to be finger tight.

5. Locate the drivers side perch mount (Part # 18227). Fasten this mount into the original forward leaf spring perch with the factory bolt. Do not torque yet. Locate three 1/2x1 1/2" bolts and connect the frame mounting plate to the perch mount. Once all those bolts are started, go back and torque all the bolts. Torque the 7/16" bolts to 75 ft./lbs., the 1/2" bolts to 85 ft./lbs. and the factory leaf spring bolt to 150 ft./lbs.



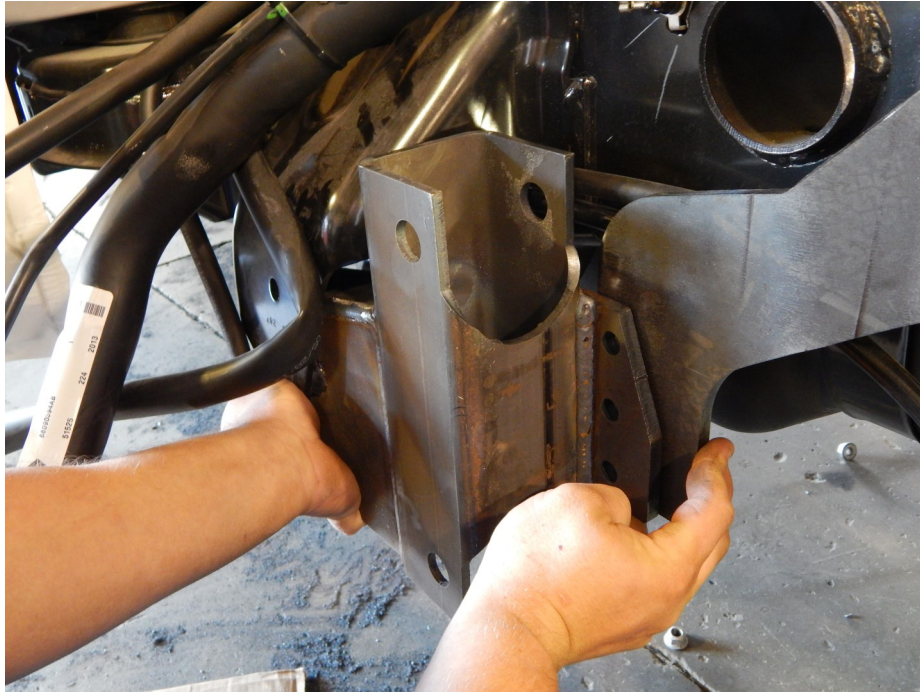

6. Once all the bolts are torqued, it is required to weld the frame mounting plates to the truck frame. Make a 3" down hand weld on the front side and a 4" weld on the back side. **Disconnect the batteries and/or use an "anti zapper" surge protector to prevent any damage to electronics when welding on vehicle.**

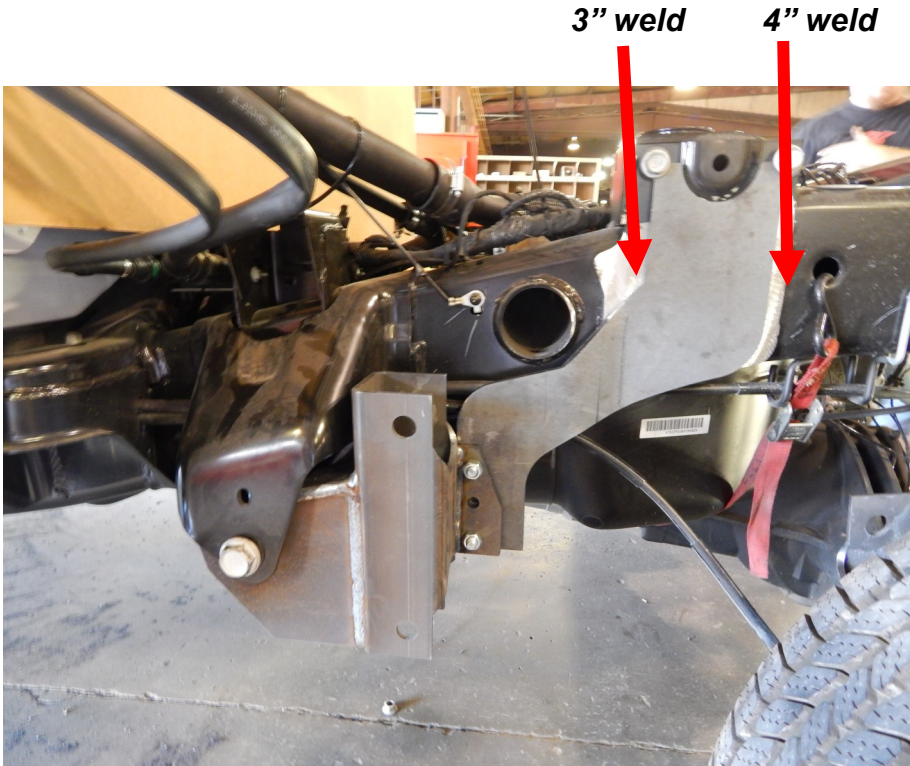

7. Locate the upper bag mount (Part # 18230). It fits where the bump stop was originally located (**removed on stock height kit only**). The flange goes on the outside of the frame and also locates it on the frame. Use a 2" weld to fasten the upper air bag mount in place.

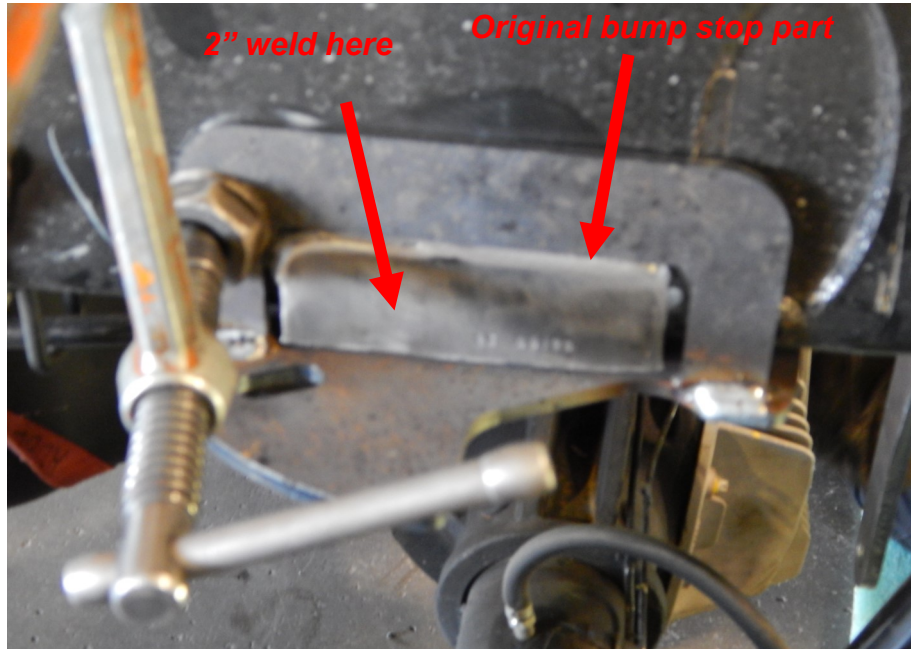

8. Locate the lower air bag mount (part# 18237) and the axle clamp (part# 10043). Place the air bag mount on top of the axle leaf spring perch and drop the 5/8x8 1/2" bolts down from the top. Next slide the axle clamps up over the bottom of the axle and fasten to the 5/8 bolts. Torque these bolts to 150 ft/lbs.

9. Repeat steps 4-8 on the passengers side.





10. Locate the pan hard bar mount (Part # 18217) and the pan hard bar backing plate (Part # 18218). These fasten to the driver's side frame rail just in front of the rear shock. Use the 1/2 x 5 1/2" bolts to clamp the assembly around the frame. Torque to 85 ft./lbs.

NOTE: On the lower rear bolt turn it around so the threads sticking out of the bolts don't rub on the shock cover.

11. Locate the trailing arms (Part # 18035) and the 7/8 x 5" bolts. Set the arms so there is 9" between the knuckles. This measurement is approximate and additional adjustment may be required upon completion. Insert the perch mount bolts from the outside in (nuts go on towards the frame of the truck). The lower air bag mount has the bolts the opposite way (nuts towards the tire side). NOTE: If the bolts are inserted incorrectly there is clearance risks that cause damage to the suspension and/or truck frame.

may *Make sure pinch bolt nuts are away from the frame*

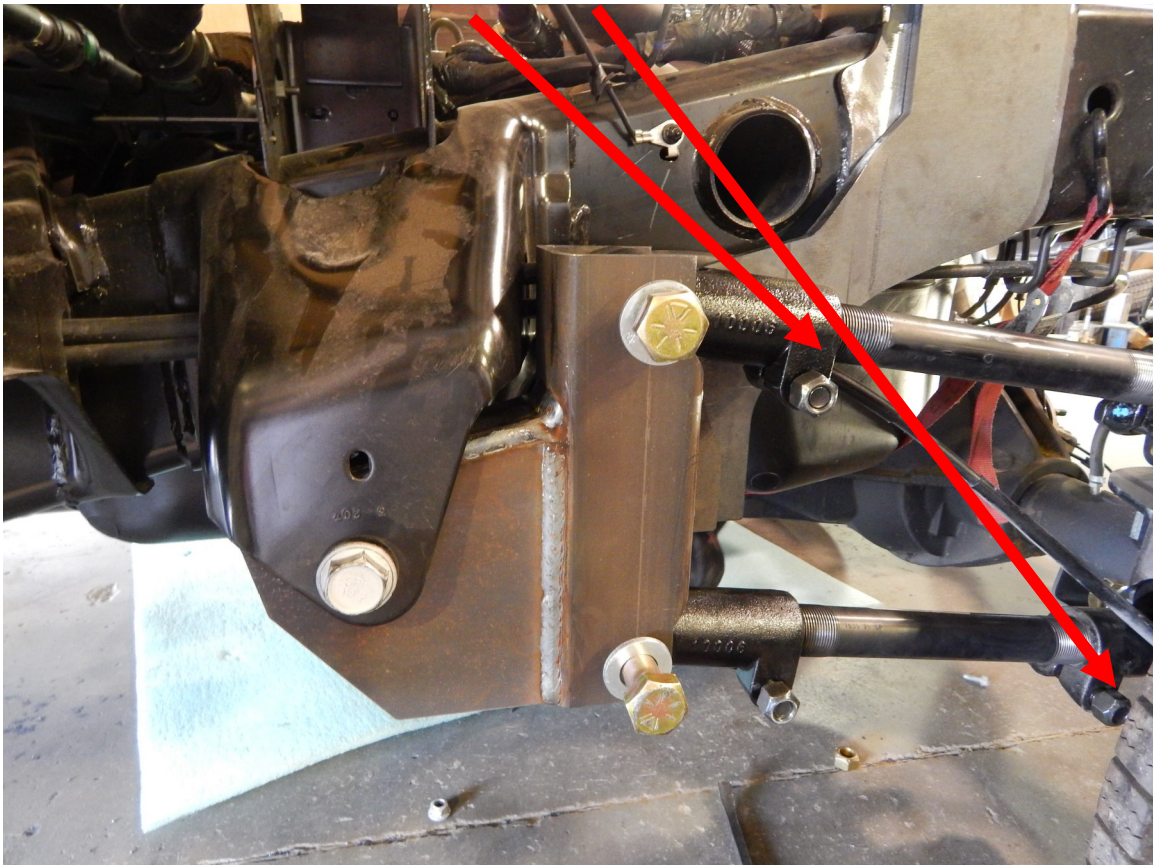



12. Locate the F5748 air bags and the 3/4" air line 90 degree fitting. Insert the fitting into the bag and snug the fitting so it will point to the rear of the truck when installed. Attach the air bag to the upper bag mounts with one 3/8 x 1" bolt. Use the lock and flat washer. The bottom of the air bag fastens to the lower air bag mount with the 3/4" nut and lock washer. Torque the 3/8" bolt and 3/4" nut and air fitting to 35 ft./lbs.



13. Locate the accumulator tanks. They mount to the original rear leaf spring perch with the factory bolt. Make sure that the large port is facing to the front of the truck. Once it is installed, locate the 3/4" air line and connect the accumulator tank and air bag. The small port will connect to the output on the controls.

14. Locate the pan hard bar and 4 spacers. The pan hard bar fastens to the lower bag mount on the passenger side and the pan hard bar mount on the drivers side. Use the 3/4 x 3" bolts to fasten in place. Make sure to put a spacer on each side of the heim end. Once installed torque the 3/4" bolts to 175 ft./lbs.

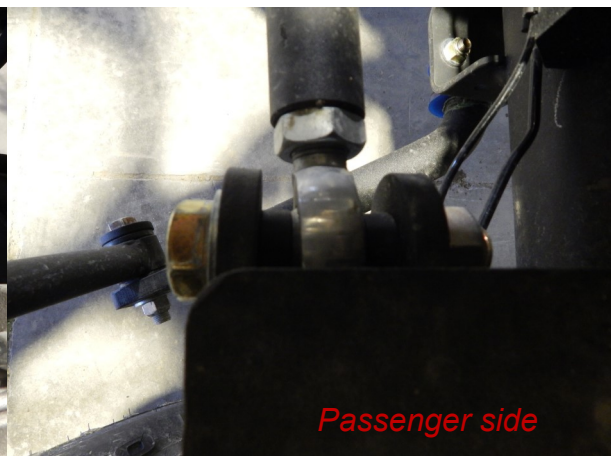
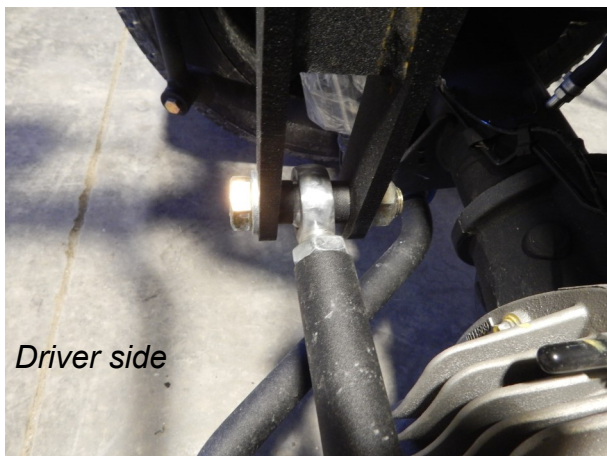

15. Locate the sway bar, blue bushing, "D" rings, end links and upper end link mounting brackets (single rear wheel only part #xxxx). Use the provided grease and slide the blue poly bushings over the sway bar. The grease helps prevent the bushings from squeaking. The sway bar fastens to the bottom of the shock mounts located on the bottom of the axle with the 3/8 x 1 1/2" bolts. Install with sway bar ears pointed towards the rear of the truck. Torque these bolts to 35 ft./lbs.
16. Locate the sway bar end links. On dual rear wheel trucks, the top of the end link fastens into the original over load leaf spring pad. Remove the factory rubber pad and drill the hole out to 17/32". Rock the drill fore and aft lengthwise with the truck to provide the end link with needed articulation. The end links fasten to the outside of the sway bar with the 1/2x3" bolts. Make sure to place the large flat washer on the outside of the end link. Before the top of the end link is installed, slide the large flat washer on, then a red "donut" bushing and insert through the hole in the overload pad. Slide on another red "donut" bushing, large flat washer and lock nut. Just snug the lock nut up where the red bushing just begins to squish.

Thick Flat washer



End links mount towards the tires

Large washer Drivers side

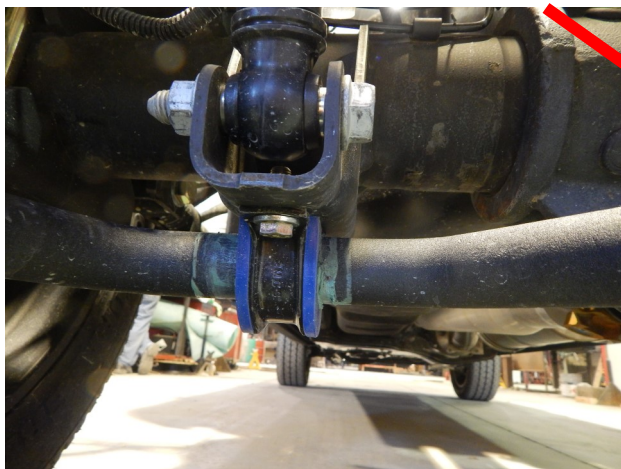

Compressor Box Self-Leveling Kit Wiring Diagram (ambulance prep package)

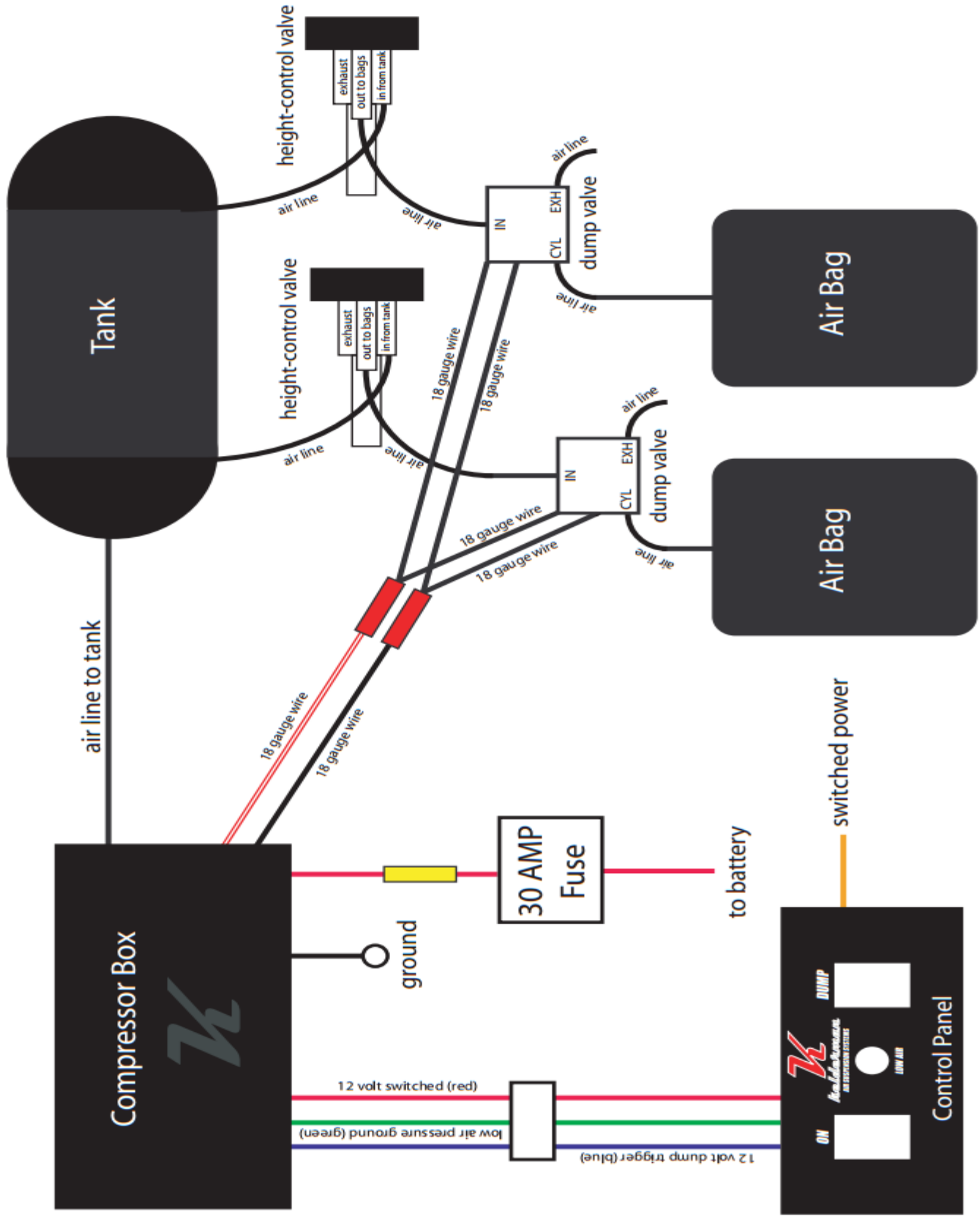

Tuesday, November 19, 2013 10:23:14 AM

ITEM NO.	PART NUMBER	DESCRIPTION	QTY.
1	18221	(PS) Frame Mounting Plate	1
2	18221	(DS) Frame Mounting Plate	1
3	18223	(PS) Perch Mount	1
4	18230	(DS) Upper Bag Mount	1
5	18231	(PS) Upper Bag Mount	1
6	18237	(DS) Lower Bag Mount	1
7	18227	(DS) Perch Mount	1
8	18218	(PHB) Frame Mount	1
9	18217	Pan Hard Bar Mount	1
10	18250	(PHB) 31"	1
11	18349	(PS) Lower Bag Mount	1
12	10043	4" Lower Round Adle Clamp	2
13	18035	10 5/8" Trailing Arm (Central Arm)	4

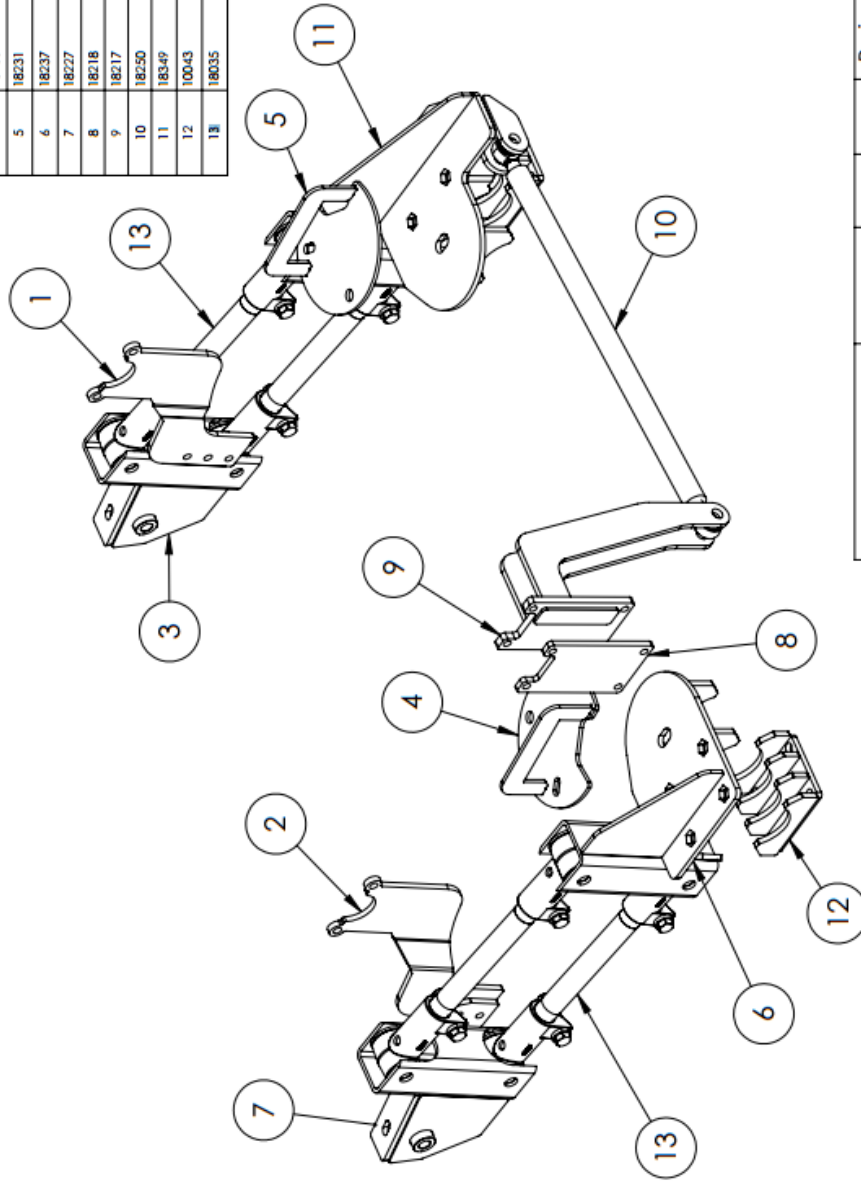

UNLESS OTHERWISE SPECIFIED: DIMENSIONS ARE IN INCHES TOLERANCES FRACTIONAL: ± 1/32" ANGULAR: MACH: 1 BEND ± 1 TWO PLACE DECIMAL: ± .000 THREE PLACE DECIMAL: ± .010		DESIGN BY ZPB	PROJECT: 2013 Dodge G5 3500 Stock Height
PROPERTY AND CONFIDENTIAL THE INFORMATION CONTAINED IN THIS DRAWING IS THE SOLE PROPERTY OF KELDERMAN MFG. INC. ANY REPRODUCTION IN PART OR AS A WHOLE WITHOUT THE WRITTEN PERMISSION OF KELDERMAN MFG. INC. IS PROHIBITED.		SHELF# / QTY NEW DXF RUN QTY:	TITLE: Final Assembly
Welderman PROPRIETARY AND CONFIDENTIAL THE INFORMATION CONTAINED IN THIS DRAWING IS THE SOLE PROPERTY OF KELDERMAN MFG. INC. ANY REPRODUCTION IN PART OR AS A WHOLE WITHOUT THE WRITTEN PERMISSION OF KELDERMAN MFG. INC. IS PROHIBITED.			
SIZE DWG. NO. A D4R4-3-X-13		SCALE: 1:20 DO NOT SCALE DRAWING	
		SHEET 1 OF 4	