



VERSION 1.2

KLM22343

kelderman.

AIR SUSPENSION SYSTEMS

2686 Highway 92 - Oskaloosa, IA 52577
phone: 641.673.0468 - email: info@kelderman.com
www.kelderman.com

2015-2016 Ford F-450 Pickup 4-Link Rear Installation Instructions



Installation

1. Before doing anything, measure the pinion angle and write the angle down. This is important because you will need to put the axle back to this measurement after the installation. Also, take a measurement from the front of the axle to a location on each side of the frame. Write these measurements here. Pinion angle _____. Right side _____ Left side _____ **NOTE: All the bolts in this kit use a flat washer on each side of the bolt.** It is not required to remove the bed, but if you have the ability to, it will make the install much easier.
2. Jack up the rear of the frame so that most of the tension is off the leaf springs. Place a set of jack stands under the frame, block the tires so the axle won't move and place a jack stand under the pinion so it doesn't rotate. Remove the leaf springs and the front overload pads. Remove the bolts that hold the sway bar to the axle and let it hang from the end links. Also, on the passenger side shock, remove the top of the shock from the mounting bracket and lean it forward. The best way to remove the riveted pads is to use a torch to cut the rivet heads off. Make sure that there are no fuel lines, brake lines, or wiring that can be damaged while cutting the rivets off. Remove the little stud that held on the case leaf spring perch.

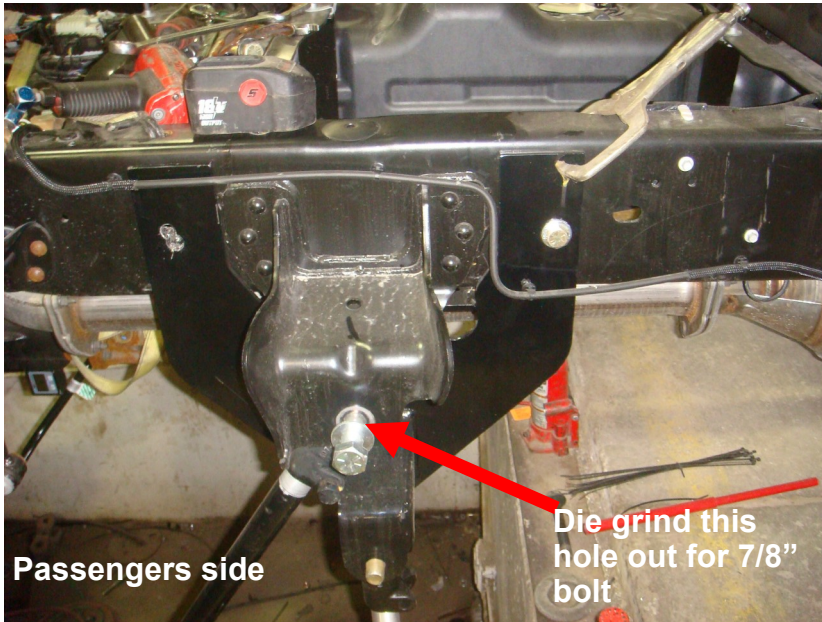

3. Locate the front trailing mounts (Part # 70508DS, 70509PS). Bolt to the front leaf spring mount with a 7/8 x 7 1/2" bolt. You will have to die grind out the hole about 1/32" to get the bolt through. Use the 5/8 x 2" bolt to fasten the rear hole. The front hole will have to be drilled as well as one hole in the lower bracket that connects the side mount to the bottom of the frame. Use the 1/2 x 1 1/2"

bolts in the bottom of the frame. **DO NOT TIGHTEN ALL THE BOLTS UNTIL THE TRAILING ARMS ARE INSTALLED IN STEP 7** (1/2"-85 ft./lbs., 5/8"-150 ft./lbs.) Repeat on the drivers side. The fuel tank cover will have to be trimmed to allow for the trailing arm mount to attached. See picture on next page. **MAKE SURE TO PUT SOMETHING IN BETWEEN THE FRAME AND FUEL TANK WHEN DRILLING THE HOLES IN THE DRIVERS SIDE** so you don't drill a hole in the fuel tank or fuel lines.

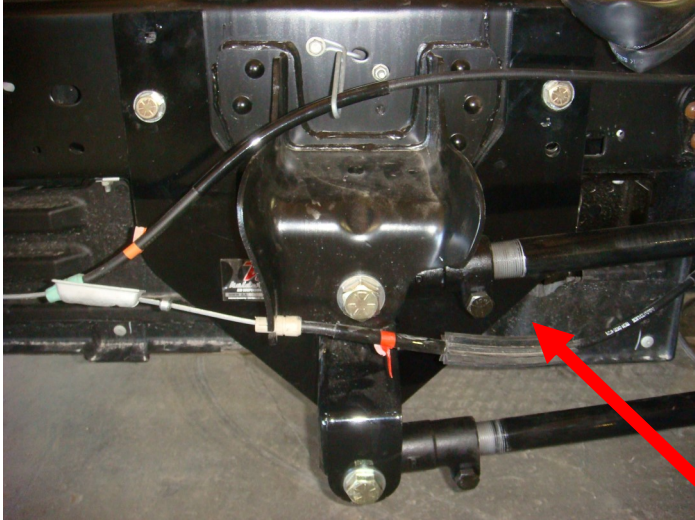

Drivers side forward trailing arm mount installed.

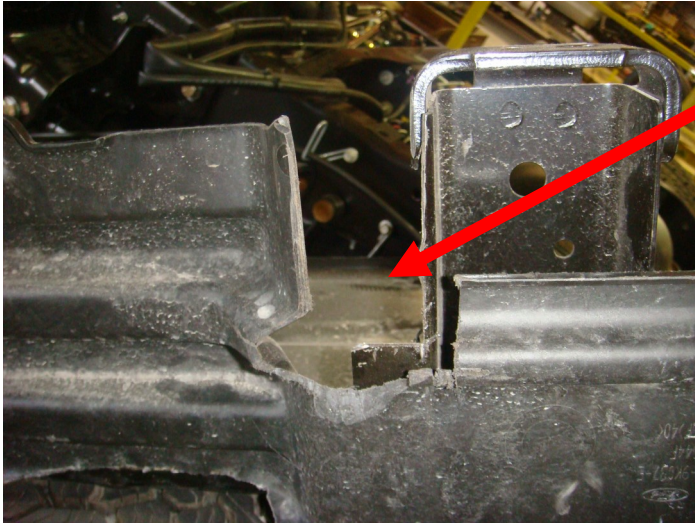

Notch the fuel tank cover so for clearance for the forward trailing arm side mount (drivers side)



Sway bar dropped from the axle. Passenger side shock attached at the bottom mount only. The strap is used to keep the pinion angle somewhat close to the correct setting.

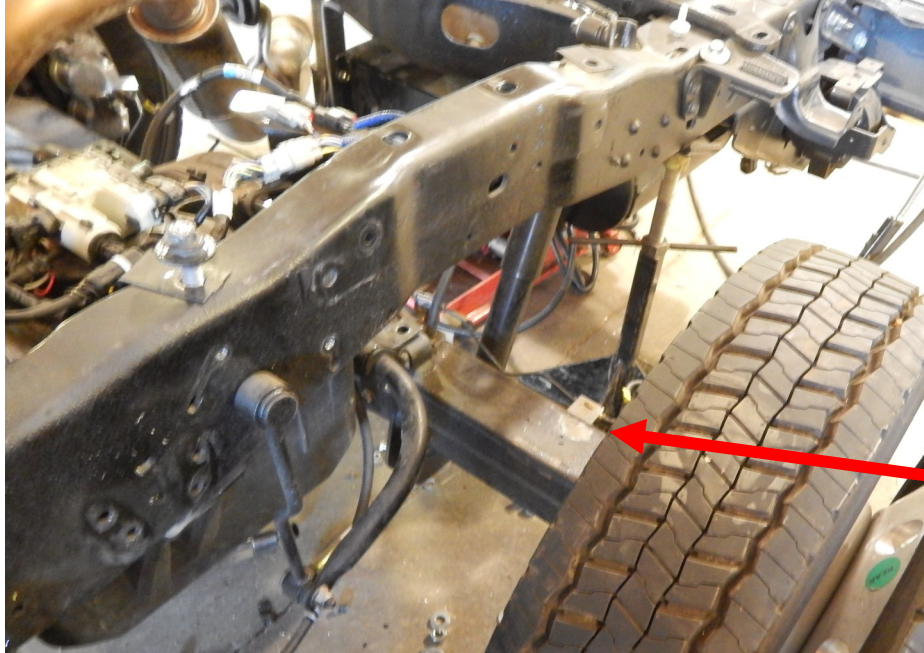

Drivers side with leaf springs removed and prepped for install

Grind the stud of the top of the axle where the axle perch was located

4. Locate the breather on the drivers side of the axle. You will need to remove the bracket that holds the brake line distribution block and cut 1/4" off the front side of it. While you are in this area, remove the top bolt of the sway bar bracket.

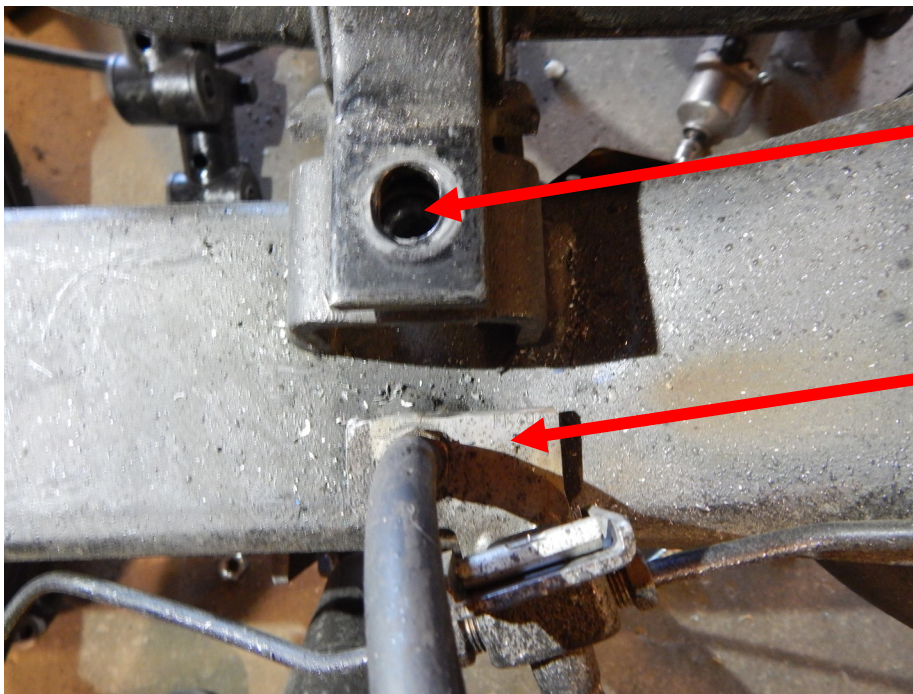

Remove this bolt it will not be reused. A longer bolt is used in step 11.

This is the bracket after it is shortened.

5. Locate the pan hard bar lower cross member assembly (Part # 22337). The front of the bracket fastens to the top six axle bolts. First you will remove the emergency brake cable bracket from the top of the axle. This bracket also holds the rear brake line. Unclip the rear brake line and fasten it to the housing with the supplied clamp.

The e-brake cable bracket will now be relocated and fastened to the front of the cross member with the 1/4 x 1" bolt. Do not tighten the six bolts yet. You will also want to use red Loctite on the bolts when you re-install them.

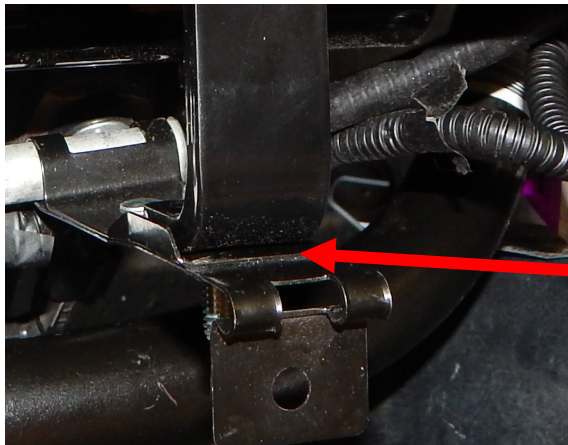

Emergency brake cable bracket bolts to tab on front of air ride cross member

Zip tie the sensor wiring harness to the emergency brake cable so it doesn't rub on the sway bar. It works well to pop the white plastic holder out of the steel tab and just zip tie the harness to the tab and not use the white plastic holder.

Brake line mounted on top of axle housing



6. Locate the drivers side upper air bag mount (Part # 22330). It fastens to the side of the frame with the 1/2 x 2" bolts. Remove the two 8mm bolts that are holding the inner brake line mounting brackets. If the truck has the Ford 5th wheel, remove the angle bracket and discard. Place the upper air bag mount against the side of the frame and use the two 1/2 x 2" bolts and one 5/8 x 2" bolt to attach. Insert the threads out so if the truck has a 5th wheel plate you can use the supplied brackets (Part #111111). Go ahead and torque the 1/2" bolts to 85 ft./lbs. and the 5/8" bolts to 150 ft./lbs. Lastly, locate the two M8 x 40 bolts and place refasten the inner brake line structure. Torque these bolts to 35 ft./lbs.

M8 x 40 bolts

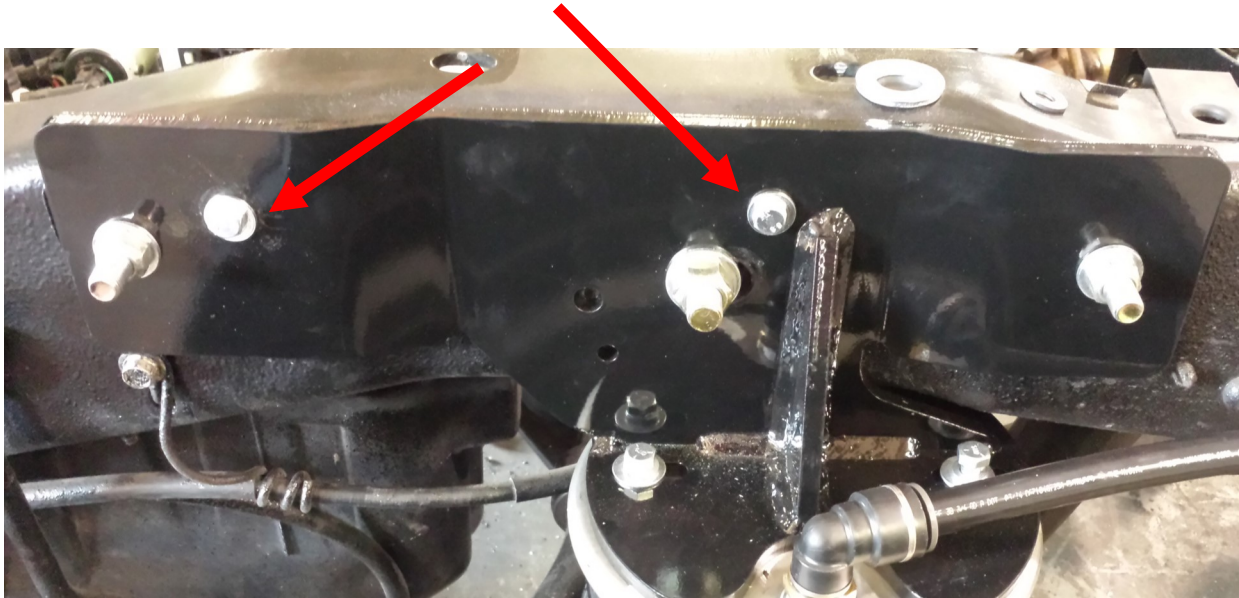

If the truck is equipped with the Ford 5th wheel hitch plate, use the brackets (Part # 22344-22347) to fasten the plate to the side of the upper air bag mounts.



7. Locate the passenger side upper air bag mount (Part # 22331) and the upper pan hard bar frame mount (Part # 22335). Put the upper air bag mount in position with the two 1/2 x 2" bolts. Snug the bolts. Use a 17/32" bit to drill out the hole just forward and down of the oblong slot. The oblong slots in the frame and air bag mount should match up pretty close. Once the hole is drilled, locate the PHB frame mount. Put it in position with the 5/8 x 2" and 1/2 x 2" bolts. Using a 1/8" bit (or something close) drill a pilot hole the best you can in the center of the lower hole in the PHB mount. Once you get the hole drilled, drill the hole out to 17/32". You will need to drill this hole from the bottom up. Use the 1/2 x 1 3/4" bolt to fasten the PHB mount to the bottom of the frame.

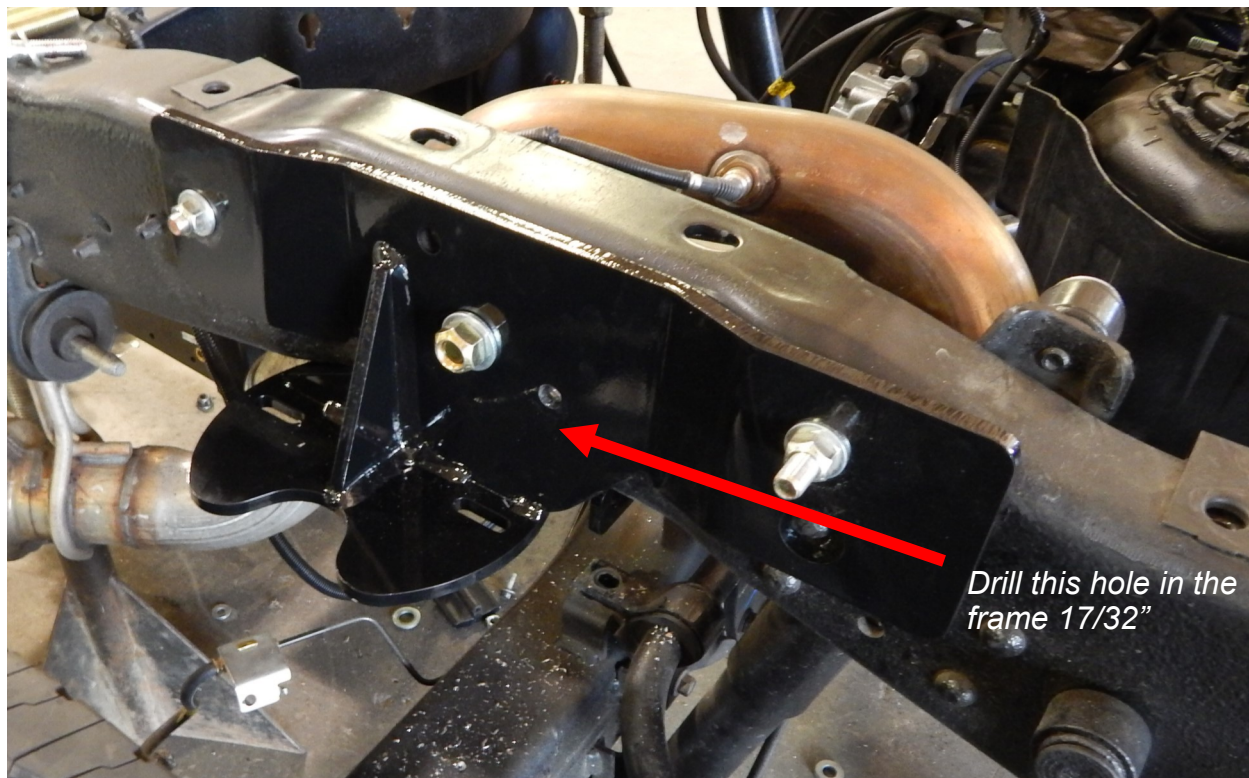

8. Locate the drivers side lower air bag mount (Part # 22323) and the Firestone F5748 air bag. Locate two of the 5/8 x 8" bolts. Check the bottom air bag stud to make sure the bottom thread has been cut off. If not, make sure the nut is installed and cut the bottom thread off with a cut off wheel or sawzall. The studs vary about a 1/16" and if the stud is on the long side then the bag may not fit flush on the lower bag mount. Drop the two 5/8 x 8" bolts down on the inside portion of the lower bag mount. Slide

the air bag into position. The lower cone of the air bag will cover the bolt heads. Before tightening the air bag, make sure the fitting is facing the outside of the air bag mount and the bolt holes are in a straight line. Once everything is squared away, tighten the air bag nut to 35 ft./lbs.

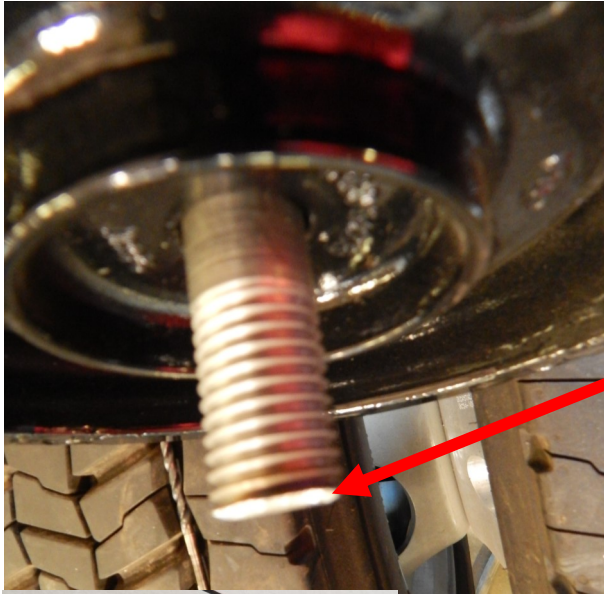

The air bag stud needs to be shortened 1/8" if it has not been cut proceed to cut the bottom thread off.

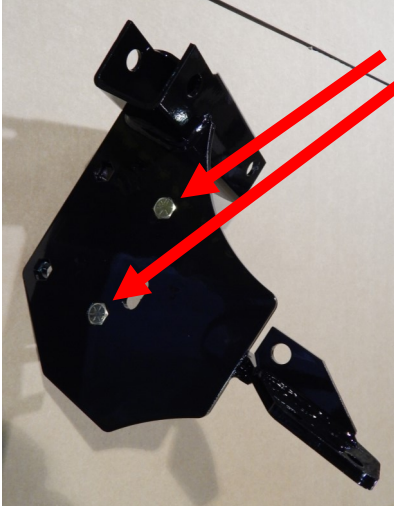

Insert the two inner 5/8 x 8" bolts

Once the air bag is placed in position make sure the air port is towards the outside of the bracket and the bolts for the air bag are parallel with the bolts that fasten the lower bag mount to the axle.



9. Locate the passengers side lower air bag mount (Part # 22338). Grab the other F5748 air bag and install it on the air bag mount just like the drivers side was done.

10. Locate the other four 5/8 x 8" bolts and the lower axle clamps (Part # 22336PS and 22323DS). You will also want two trailing arms (Part # 10567) and a pair of 7/8 x 5 1/2" bolts. Install the lower bag/air bag assembly down on top of the axle. The tab on the lower bag mount goes on the back side of the pan hard bar cross member (pictures are on the next pages). Drop the two 5/8 x 8 1/2" bolts down. Grab a trailing arm and set the distance between the knuckles at 15 3/4". Locate the lower axle clamp for

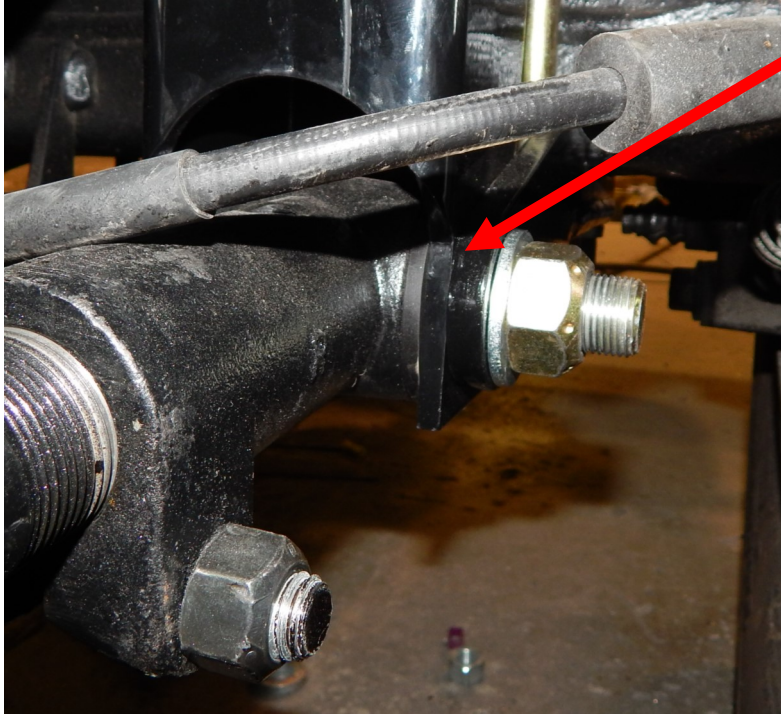

whichever side you are working on. **NOTE: THE TAB GOES ON THE OUTSIDE OF THE SQUARE TUBE (TOWARDS THE TIRE).** Slide the axle clamp up tight and snug it up to the axle with the extended nuts and washers. DO NOT TORQUE YET. Grab the trailing arm, slide it in position and insert the 7/8 x 5 1/2" bolt from the inside out (towards the tire). The bolt should go through the tube and then through the tab on the lower axle clamp. Go ahead and slide the washer and nut on but do not tighten yet.

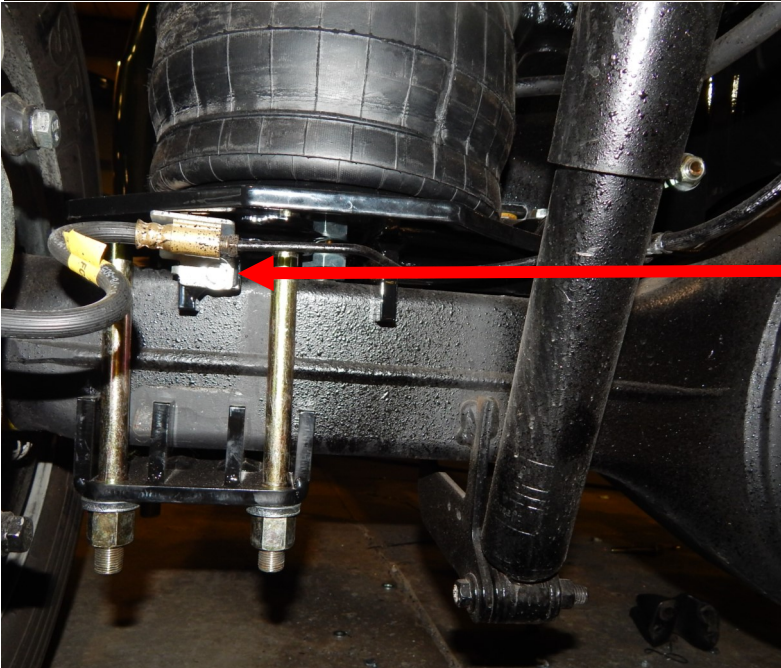

Fasten the brake line on each side to the tab on the lower bag mount with the 1/4 x 1" bolt

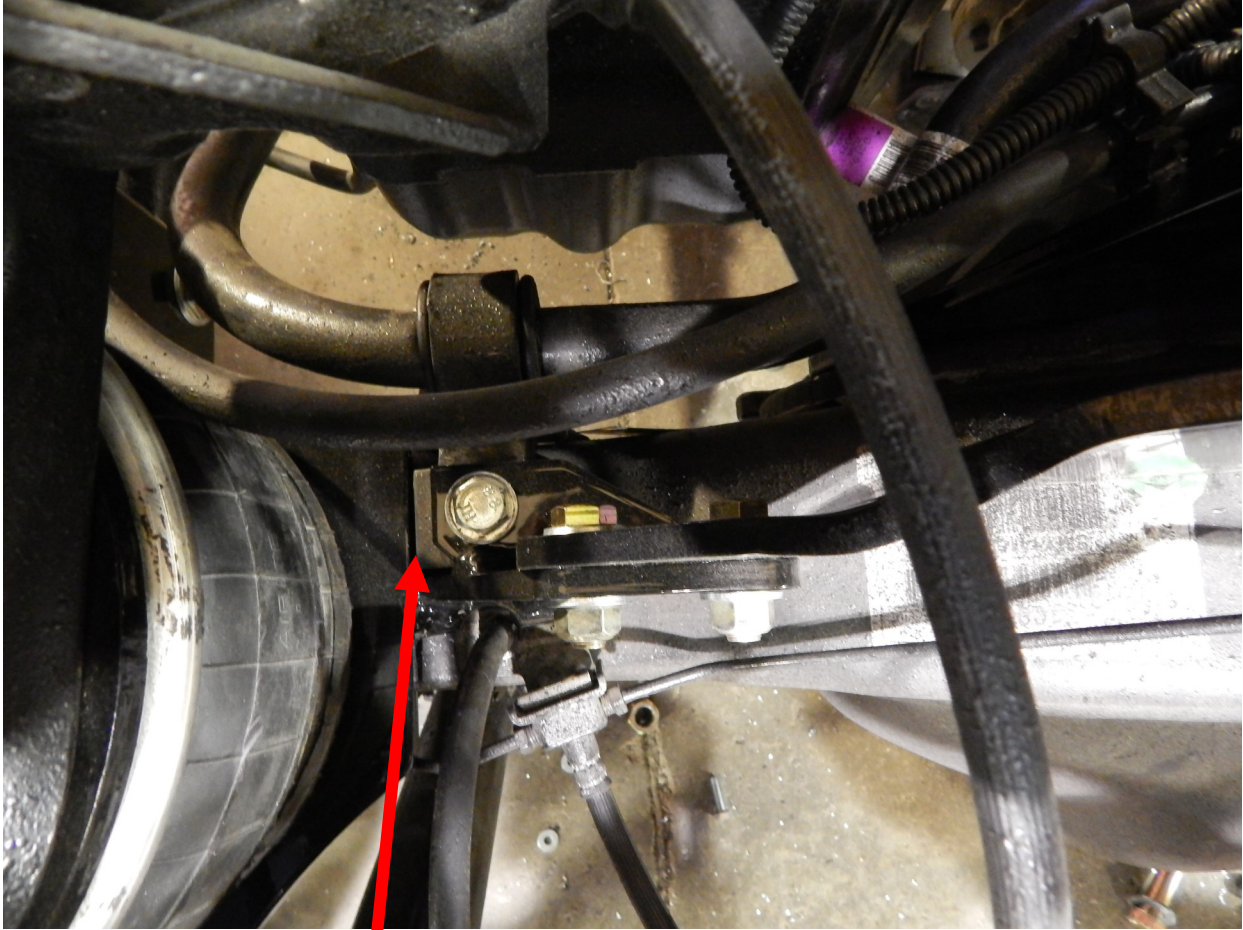

The lower air bag mount will almost be touching the sway bar mounting bracket on the axle

11. There are three more bolts that hold each side of the lower air bag mounts in place. The bolts that fasten into the top sway bar bracket are M12-45. Use Loctite on these bolts. The bolts that fasten to the pan hard bar cross member are 1/2 x 2". To get these three holes to line up the lower air bag mount will almost be touching the sway bar mount on the axle. Use a drift or punch if needed to line up the 2 holes with the cross member. Once all the bolts are started, begin the tightening process by torquing the 5/8 x 8" bolts to 155 ft./lbs. Tighten the M12 bolt to 55 ft./lbs. Lastly the 1/2 x 2" bolts get torqued to 85 ft./lbs. This procedure needs to be done on both sides. While your under the axle go ahead and fasten the brake lines to the tabs with the 1/4 x 1" bolt.



12. With the lower air bag mounts are torqued go ahead and torque the six differential bolts on the front side of the lower pan hard bar crossmember. Tighten to 85 ft./lbs.

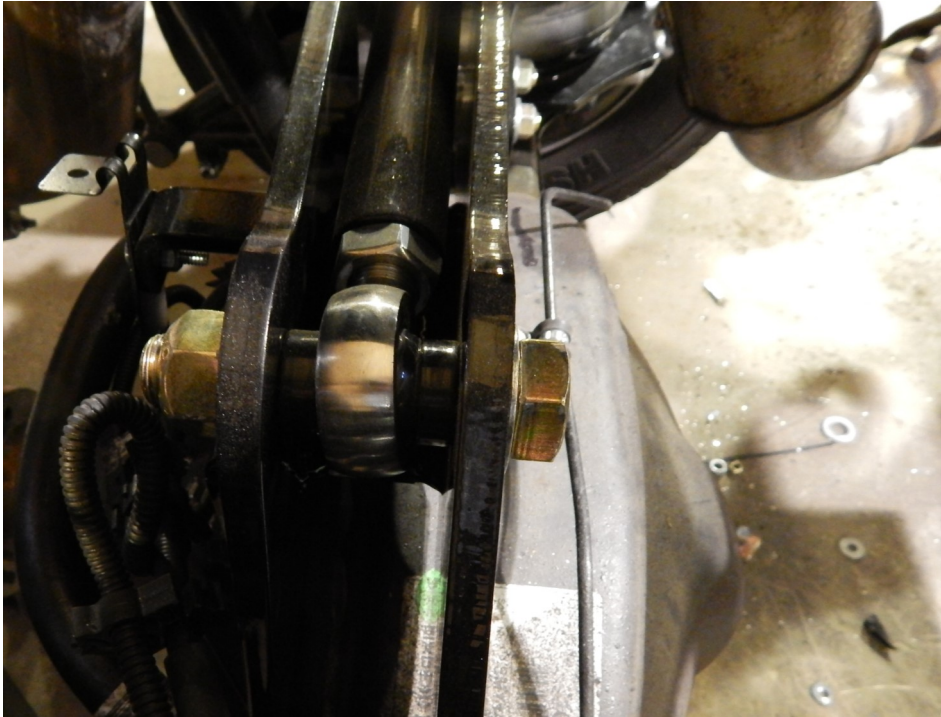

13. Locate the pan hard bar (Part # 22339) and the four spacers. Adjust the pan hard bar so it is 18 3/8" center to center. Fasten the pan hard bar into the each of the pan hard bar mounts. Use a spacer on each side of the heim ends. Do not torque the 3/4" bolts until the final set up is complete. You will have to lift up the pan hard bar to tighten the jam nuts. **AFTER STEP 14 IS DONE**, check the frame to inside of the tire measurements on each side. Set the distances the same and then torque the 3/4 x 4" bolts to 150 ft./lbs.

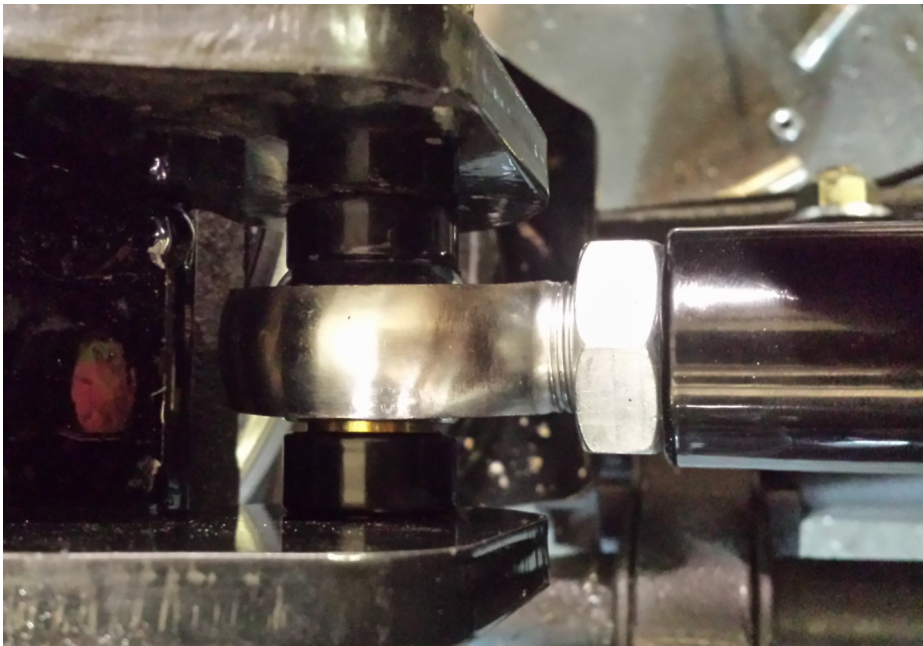



1/2" spacer goes on upper trailing arm

14. Locate the other 2 trailing arms (Part # 10567), upper spacers (Part #30267), four 7/8 x 7 1/2" bolts, and two 7/8 x 5" bolts. Use the 1/2" spacers on the upper trailing arms, factory leaf spring perch. They go on the inside between the cast knuckle and spring perch. Use a 7/8 x 7" bolt here. The other end of the trailing arm connects to the lower air bag mount. Set this bar so there is 16 1/4" between the knuckles. Use the 7/8 x 5" bolt there. Insert the bolt from the inside out so the nut side is away from the frame. The lower trailing arms mount to the forward trailing arm mount using 7/8 x 7 1/2" bolt. The rear fastens to the lower bag mount with the 7/8x5 1/2" bolt. Each truck varies a bit, so your trailing arms may be up to 1/4 to 3/8" different in measurement.

*Bottom bar:
15 3/4" be-
tween knuck-*

Insert bolts so the head is away from frame

*Top bar: 16 1/4" between knuckles
Bottom bar: 15 3/4" between knuckles*



15. Locate the accumulator tanks (Part # 21002). The tanks mount to the rear factory leaf spring shackle perch with the factory bolts. Make sure to mount to the large port faces forward. Insert the straight fitting in the tank. Use Teflon tape on the threads. The rear tank port uses the 1/4" air line fitting. Again, use Teflon tape on the threads (unless it is supplied with it). Cut the 3/4" air line around 23" long and connect the tank to the air bag.



16. Locate the air tank and fittings. The tank can fasten to the truck frame or to the rear factory cross member in front of the rear tire. If mounting on the cross member, remove the rear tire before you drill the holes for the air tank. Hold the tank up and mark the four holes. Drill the holes and fasten with the 3/8 x 1" bolts.

17. Locate the rear sensors (optional electronic system). For (optional) mechanical system, go to the page 15 and 16. They fasten to the sensor mount with two 1/4 x 1" bolts. Fasten the plastic collar to the upper trailing arm with the ball inside. Connect to the sensor with the linkage arm.

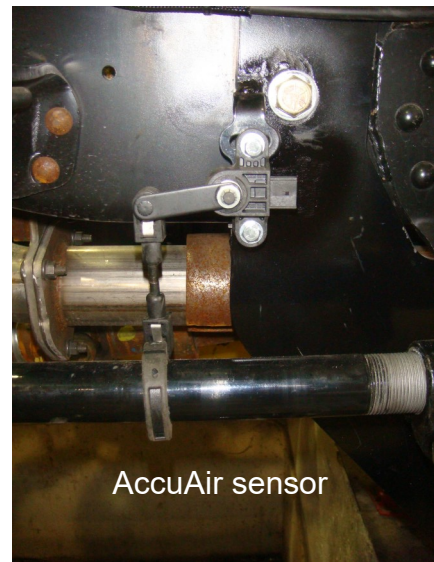



Air tank mounted on the outside passenger side frame rail . The bracket needs to be bent for it to work here. 2 bolts are enough to hold he tank in place

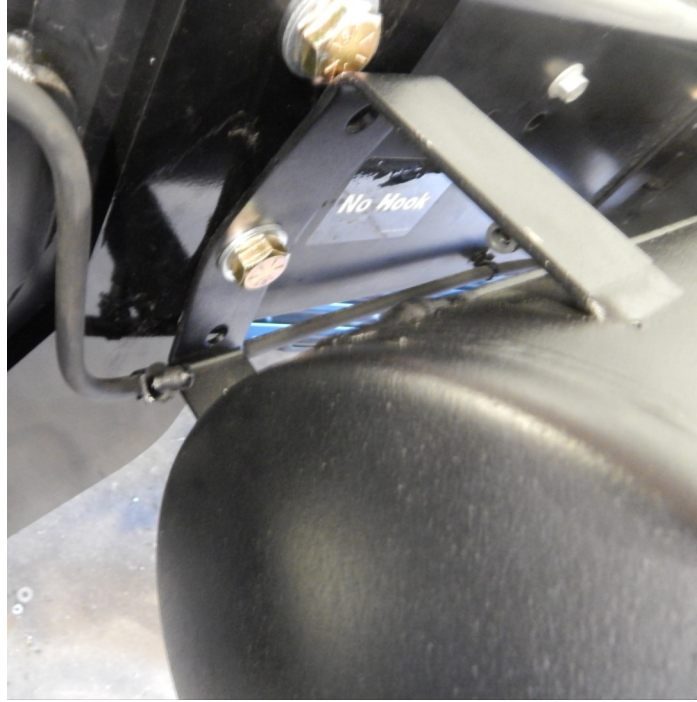

This is the mechanical height control valve at ride height (air bags at 8") Use the slot on the top bolt to adjust the valve

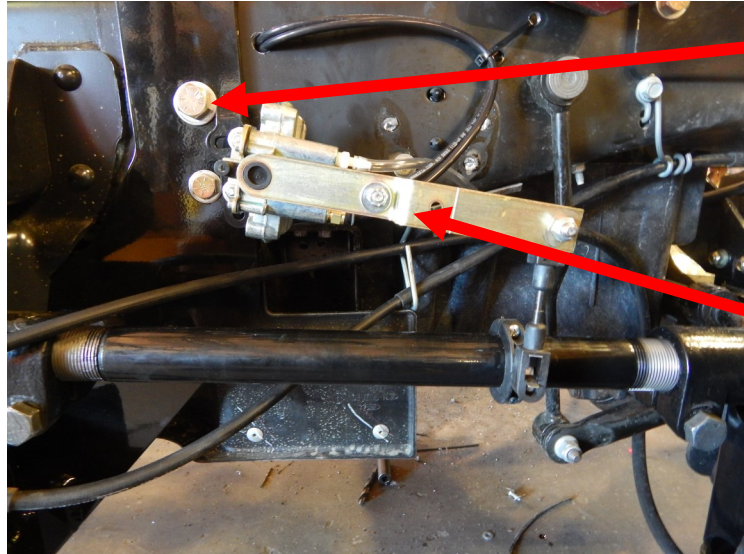

Fine tuning can be done by adjusting the lever once this bolt is loosened.

18. Locate the air compressor box. The box mounts anywhere on the inside or outside of the frame that has enough room for it. If you are installing the Hadley system, you will mount it to the rear drivers side of the frame where the rear leaf spring perch was located. Use the instructions for the air control system to plumb and wire up.

19. Alignment: You will adjust the four link bars to get the original wheelbase and original pinion angle. Refer to your original measurements in Step One. The best way to do this is to put a jack stand under the rear hitch and let all the air out of the bags. Do this with the air bags measuring 7 1/2-8" tall. This measurement is between the upper and lower bag mounts. Adjust the trailing arms by getting the upper and lower arms the same length. Turn each arm 1/2 turn at a time. If you get the arms over one turn off from each other they will bind up.

20. Once the alignment is done, go back and torque the 7/8" bolts to 320 ft./lbs. Torque the trailing arm set bolts to 85 ft./lbs. Go back and double check the rest of your bolts to make sure they are torqued.

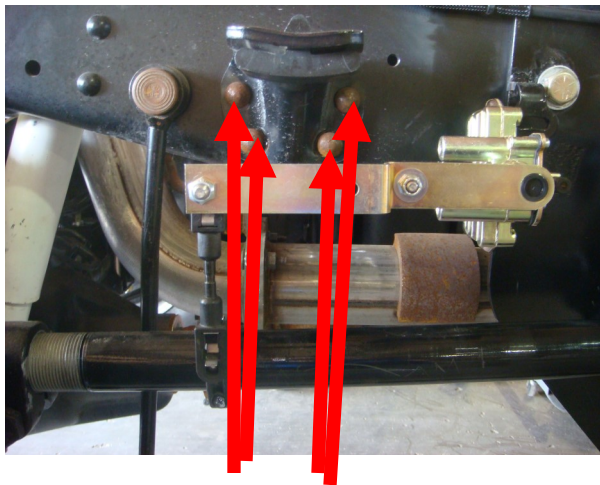

Mechanical system and Hadley system
The leveling valve connects to the sensor mount with the 1/4 x 1" bolts. When using the mechanical valve and the Hadley sensor, it is required to cut off the overload pad rivets. Use a torch to do this. Make sure not to burn any wiring or brake lines when cutting. Use the diagram on the next page for plumbing of the system.

Cut these four rivet heads off with a torch

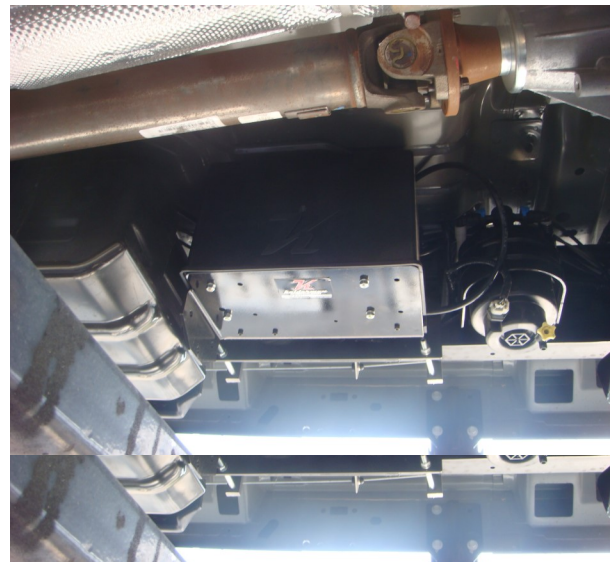
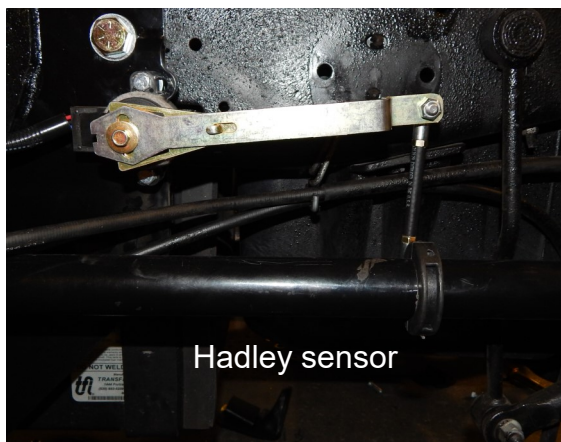

2015 F450 P/U
Kit Number: 22343

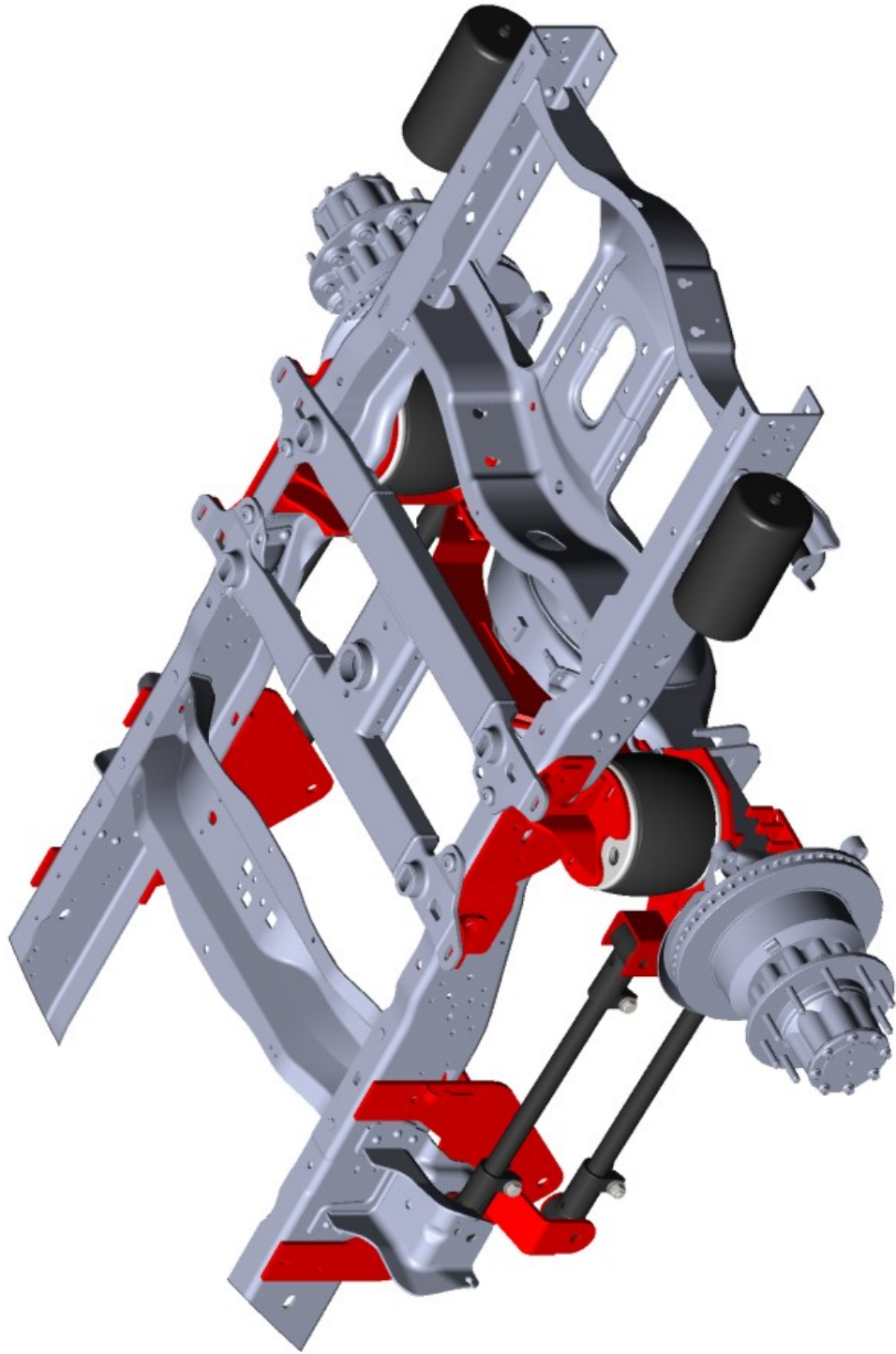

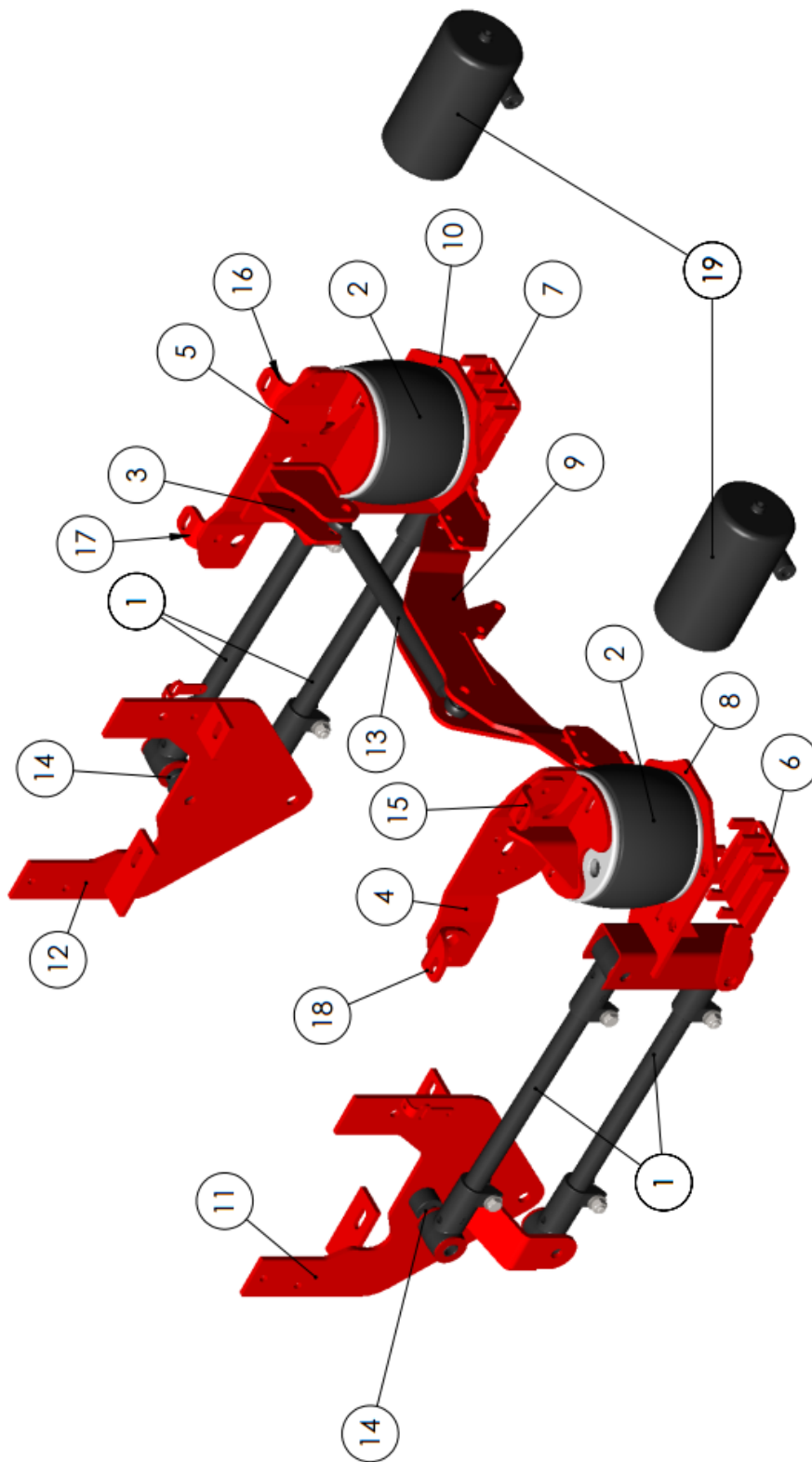

ITEM NO.	PART NUMBER	DESCRIPTION	Kit/QTY.
1	10567	Trailing Arm	4
2	5748	5748 Firestone Air Bag	2
3	22335	(PHB) Upper Frame Mount	1
4	22330	(DS) Upper Frame/Bag Mount	1
5	22331	(PS) Upper Bag Mount	1
6	22327	(DS) Lower Axle Clamp	1
7	22336	(PS) Lower Axle Clamp	1
8	22323	(DS) Lower Bag Mount	1
9	22337	(PHB) Crossmember	1
10	22338	(PS) Lower Bag Mount	1
11	70508	(DS) Side Plate	1
12	70509	(PS) Side Plate	1
13	22339	Pan Hard Bar 15" Blank w/ 3/4" Hiems	1
14	30267	Bushing - 1.5" OD x .875" ID x .5" Thick	2
15	22344	(DS) Rear 5th Wheel Hitch Mount	1
16	22345	(PS) Rear 5th Wheel Hitch Mount	1
17	22346	(PS) Front 5th Wheel Hitch Mount	1
18	22347	(DS) Front 5th Wheel Hitch Mount	1
19	21002	Ford Accumulator Tank	2

Electronic Plumbing & Wiring Diagram with Air Dryer

FRONT

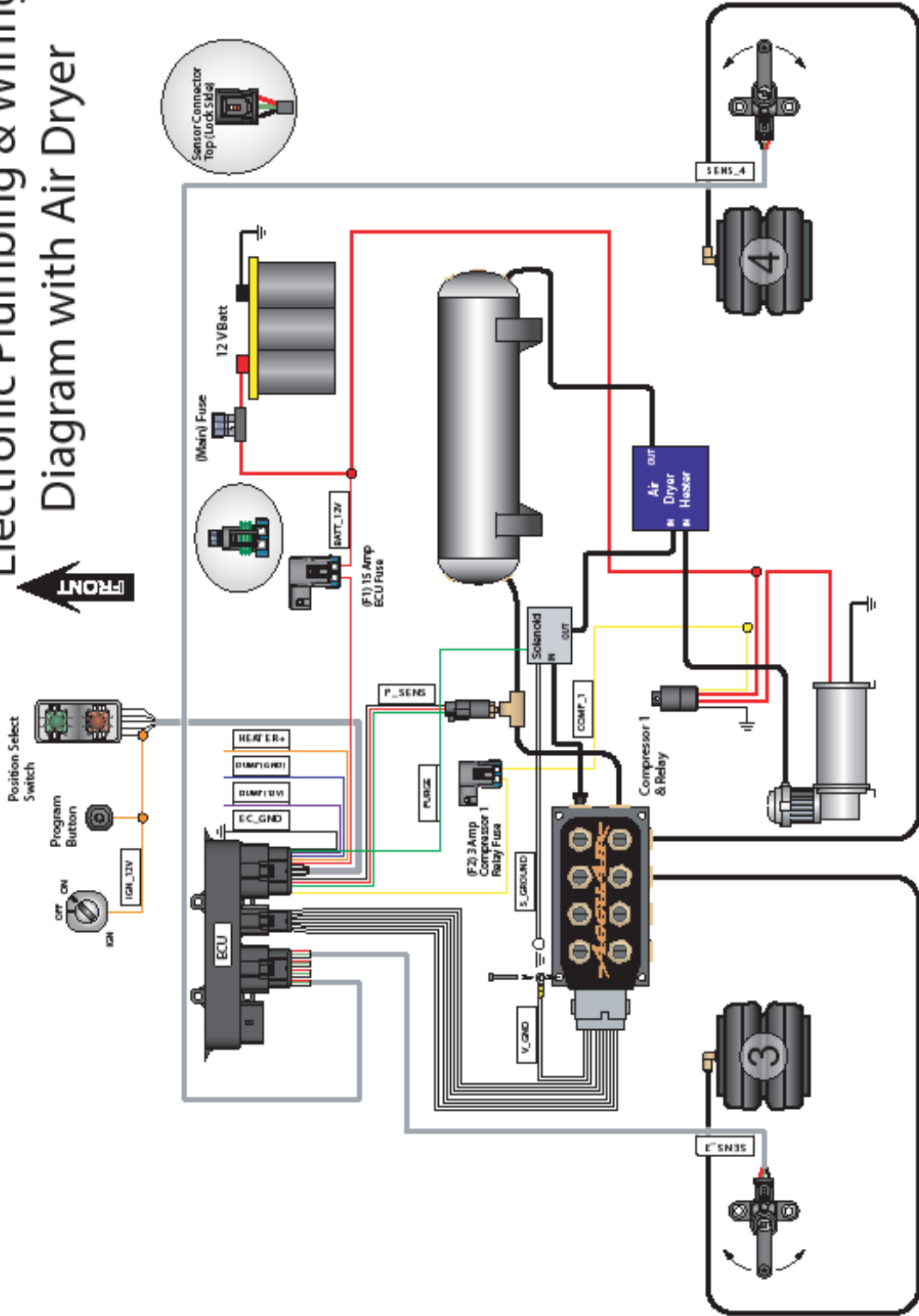

Compressor Box Self-Leveling Kit Wiring Diagram (shown with optional dump valve)

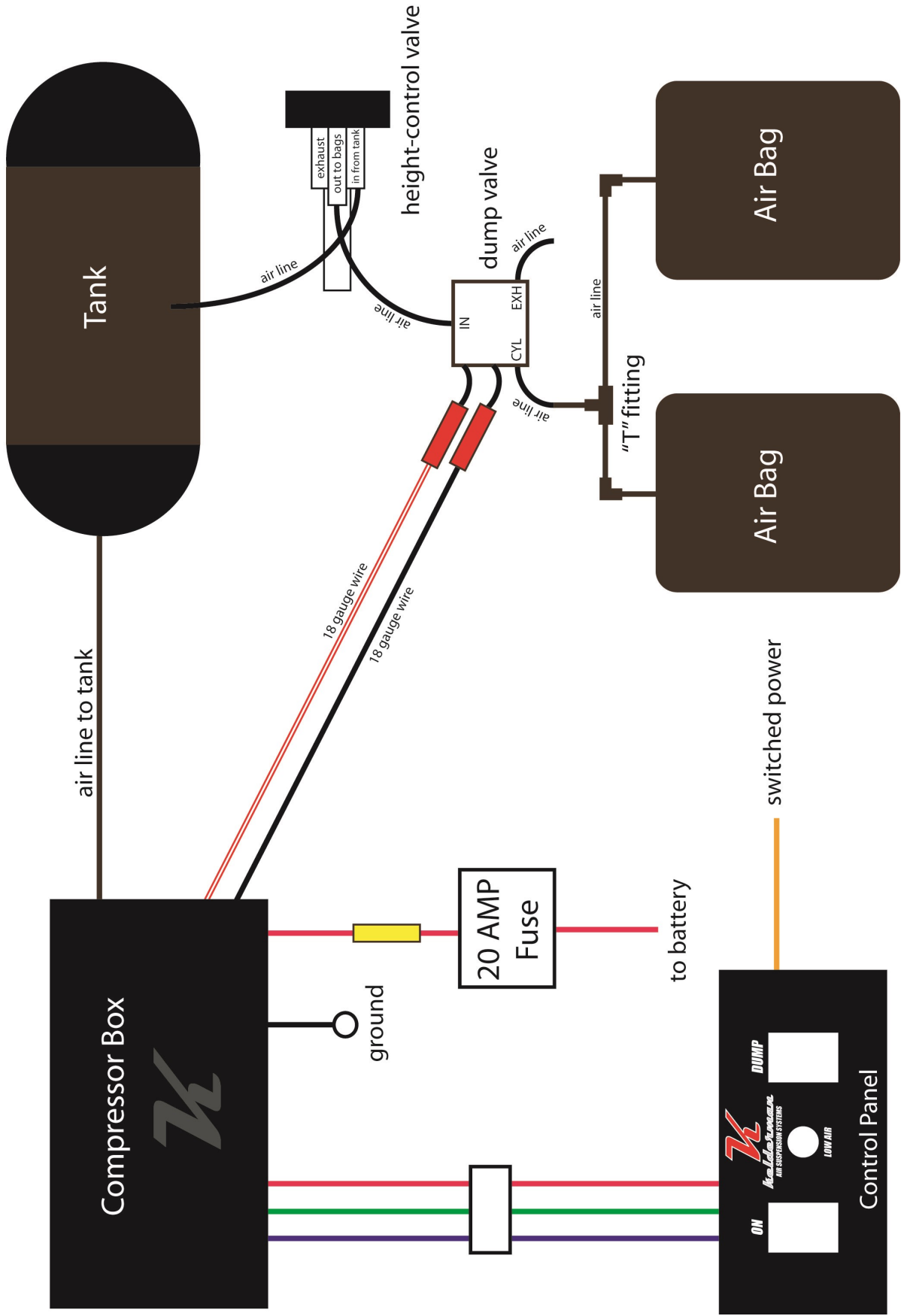

Front sensor mounts (for ESLK4 control systems) (Optional)

Passenger side

Mechanical valve mounts
to the frame drill and tap
for 1/4-20 bolt.





Commercial Product Warranty, Disclaimers and Warnings
Kelderman techs are available at 641-673-0468 M-F 7:00-4:00 CST

Kelderman Air Suspension Systems offer a 3 year/ 100,000 mile Limited Warranty, parts and labor, to the original retail purchaser who owns the vehicle on which the unit was installed, for defects in materials and workmanship related to the fabricated parts. Non fabricated parts such as air bags, air compressors, gauges, solenoid kits, and electronic or mechanical air ride control systems are covered for 1 year/ 50,000 miles for parts and labor. In cases where ride control systems manufactured by The Air Lift Company or Hadley Products are provided, the ride control warranty in this document will not apply. Instead, the warranty will be that of Hadley and Air Lift.

Kelderman Air Suspension Systems must be contacted for warranty authorization before any diagnostic work or repairs are performed. At that time, Kelderman will provide diagnostic assistance and authorization for the repairs if warrantable. Any unauthorized diagnostic work performed before contacting Kelderman will not be covered under the warranty program if deemed unreasonable.

Kelderman Air Suspension System does not warrant any product for finish, alterations, modifications and/or installation different from Kelderman's instructions. Alterations / modifications to the final product include, but are not limited to powder coating, plating, and/or welding which will void the warranty. Some damage may occur to the finish of the parts during shipping. This is considered normal and is not covered under warranty.

Kelderman tries to ensure that the suspension parts fit the vehicles they were designed for, but due to unknown vehicle manufacturer's production changes and/or inconsistencies by the vehicle manufacture, Kelderman cannot be responsible for 100% fitment.

Kelderman's obligation under this warranty is limited to the replacement of the defective parts only. Freight charges, incidental or consequential damages are expressly excluded from this warranty. Kelderman is not responsible for damages and/or warranty of other vehicle parts related or non-related to the installed Kelderman Air Suspension System. This warranty is expressly in lieu of all other warranties expressed or implied. This warranty shall not apply to any product that has been subject to accident, negligence, alteration, abuse or misuse as determined by Kelderman.

Kelderman Air Suspension Systems are designed to be installed, and run at the recommended ride heights provided by Kelderman. All warranties will become void if Kelderman systems are run outside the recommended ride heights, or if the systems are combined/substituted with other suspension kits. Combination and/or substitution of other components may cause premature wear and inhibit the Kelderman Air Suspension from operating as designed, which may cause severe injury or death. Kelderman does not warrant parts not manufactured by Kelderman.

It is the installer and sellers responsibility to review all these warranties, warnings and disclaimers with the consumer prior to installation.

Kelderman reserves the right to supersede, discontinue, change designs, finishes, part numbers and/or applications of parts deemed necessary without written notice. Kelderman is not responsible for misprints, or typographical errors within the catalog or price sheets.

December, 2011